



Air Springs



**CATALOGO RICAMBI
REPLACEMENT GUIDE**

2012



INDICE / INDEX

INTRODUZIONE / INTRODUCTION	Pag./Page 2
AVVERTENZE / PLEASE NOTE	Pag./Page 3
ISTRUZIONI CATALOGO / CATALOGUE INSTRUCTIONS	Pag./Page 5
PROBLEMI - SOLUZIONI / PROBLEMS - SOLUTIONS	Pag./Page 6/7
ELENCO ARTICOLI / ARTICLES LIST	Pag./Page 8/11
MOLLE AD ARIA COMPLETE TIPO "T" / AIR SPRINGS TYPE "T"	Pag./Page 12
MOLLE AD ARIA COMPLETE TIPO "D" e "C" / AIR SPRINGS TYPE "D" and "C"	Pag./Page 28
MEMBRANE / BELLOWS	Pag./Page 119
TABELLE COMPARATIVE MOLLE AD ARIA / AIR SPRINGS CROSS-REFERENCE LISTS	
• da codice ORIGINALE <i>from O.E. Codes</i>	Pag./Page 138
• da codici GART <i>from GART Codes</i>	Pag./Page 149
• da codici CF GOMMA <i>from CF GOMMA Codes</i>	Pag./Page 159
• da codici FIRESTONE <i>from FIRESTONE Codes</i>	Pag./Page 165
• da codici PHOENIX <i>from PHOENIX Codes</i>	Pag./Page 169
• da codici CONTITECH <i>from CONTITECH Codes</i>	Pag./Page 172
• da codici GOODYEAR <i>from GOODYEAR Codes</i>	Pag./Page 177
• da codici AIRTECH <i>from AIRTECH Codes</i>	Pag./Page 181
• da codici SABO <i>from SABO Codes</i>	Pag./Page 187



INTRODUZIONE

MOLLE AD ARIA

Le molle ad aria si utilizzano quali sospensioni di autocarri, autobus ed autoveicoli in genere. Trovano impiego inoltre come attuatore, ad esempio sui macchinari tessili e per cartiere, nelle presse per stampaggio, nei sollevatori per auto-officine, in alternativa anche ai classici pistoni ad aria e ad olio.

Le molle ad aria sono costituite da un involucro di gomma-tela ad elevata resistenza alle pressioni dell'aria richieste.

La gomma ha la proprietà di impermeabilizzare la tela e di renderla resistente agli agenti atmosferici e agli olii lubrificanti. Il tessuto ha la funzione di sopportare le pressioni di esercizio.

La chiusura ermetica delle sospensioni avviene tramite apposite flange o piatti metallici zincati, che servono anche da strutture di ancoraggio all'impianto cui è destinata la sospensione.

Vantaggi: peso ridotto - nessuna manutenzione - lunga durata - facilità di installazione - dimensioni contenute - sicurezza - confort elevato e silenziosità di marcia - caratteristiche di molleggio invariabili - altezza statica indipendente dal carico - nessun sfregamento tra parti in movimento.

INTRODUCTION

AIR SPRINGS

The air springs are used as suspensions for trucks, buses and vehicles in general. Furthermore they are used as an actuator, for example on textile machines and for paper mills, on stamping press, on lifting units for car repair shops, also alternatively to the classical oil air pistons. The air springs consist of a rubberized fabric envelope which is highly resistant to the air requested pressures.

The rubber serves to impermeabilize the fabric in order to resist against the atmospheric agents and the lubricating oils. The fabric has the function to support the working pressures.

The suspension hermetic sealing is performed either by proper galvanized metal flanges and plates which serve as anchorage structures for the installation to which the suspension is intended for.

Advantages: low weight - no maintenance - long life - easy installation - reduced dimensions - safety - excellent ride comfort and lack of noise - unchangeable springing - static height independent from the load - no friction because no sliding members.



AVVERTENZE

Tutte le informazioni riportate nel presente catalogo sono da considerarsi affidabili ed accurate, tuttavia la società Gart S.r.l. non fornisce garanzia, espressa o implicita, per le stesse. Ognuno, facendo uso di queste informazioni, lo fa a proprio rischio e si assume tutte le responsabilità derivanti dall'uso stesso.

Le caratteristiche indicate non sono vincolanti, la società Gart S.r.l. si riserva la facoltà di apportare eventuali modifiche anche senza preavviso. Per ulteriori informazioni contattare il nostro ufficio tecnico.

E' vietata la riproduzione anche parziale del presente catalogo senza autorizzazione scritta. Il presente catalogo annulla e sostituisce i precedenti e qualunque altra comunicazione in merito.

I marchi e i nominativi qui menzionati sono registrati dai rispettivi proprietari.

Tutti i nominativi dei costruttori e i relativi riferimenti originali citati nel presente catalogo sono riportati a puro titolo indicativo. I nostri prodotti non sono originali ma con essi intercambiabili.

PLEASE NOTE

The information reported in the present catalogue are believed to be reliable and accurate, however Gart S.r.l. doesn't make any warranty express or implicit of this information. Anyone, making use of this material, does so at his own risk and assume all liability for the use itself.

The characteristics of the articles indicated are not necessary binding, Gart S.r.l. reserves the right to make any change to the contents even without notice. For more information please contact our technical department.

Copying any part of this catalogue is forbidden without Gart's written authorization. The present catalogue annuls and replaces any previous catalogue and any other information communicated.

All trademarks and registered trademarks mentioned herein are the property of their respective owners.

The name of manufacturers and the o.e. references mentioned in this catalogue are given for cross-reference purposes only. Our products are not original but interchangeable with.



IQNet
THE INTERNATIONAL CERTIFICATION NETWORK

CERTIFICATE

IQNet and its partner
CISQ/RINA
hereby certify that the organisation

GART S.r.l.
VIA SAN BENEDETTO 95 36050 BRESSANVIDO (VI) ITALIA
in the following operative units

VIA SAN BENEDETTO 95 36050 BRESSANVIDO (VI) ITALIA

for the following field of activities

DESIGN, DEVELOPMENT, MANUFACTURE AND TECHNICAL SERVICING OF AIR SPRINGS AND RUBBER ARTICLES

has implemented and maintains a
Quality Management System
which fulfills the requirements of the following standard

ISO 9001:2008
Registration Number: **IT-11359**
Current Issue: 2011-12-30

First Issue: 1999-12-29

CISQ *President of CISQ*

IQNet *President of IQNET*

RINA partners: ANEC Mexico, APICER Portugal, EISO Italy, CQC China, CQM Spain, AFMQ AFNOR France, AIB-Vincent International Belgium, ANCE Germany, DS Denmark, ELDT Greece, FCAN Brazil, CQM Canada, CQS Czech Republic, Cui Cong China, KONTEC Colombia, IMC Monitor, Impresia Certification Finland, FONDOPORMA International, HQQA Asia, Hong Kong China, KONTAK Hungary, Norko AS Norway, NSAI Ireland, PCBC Poland, QMI Canada, IRAM Argentina, IQA Japan, KIQ Korea, SAI Global, Australia, SII Israel, SQ Slovenia, SERIM QMS International Malaysia, Quality Assure Austria, ER Borealis, SAI Global, Australia, SII Israel, SQ Slovenia, SERIM QMS International Malaysia, SGS Switzerland, SERAC Romania, TEST SA Paderborn Russia, TQS Serbia, IQNet is registered in the USA by AFMQ AFNOR, AIB-Vincent International, CQC, CQS, NSAI Inc, QMI and SAI Global. The list of IQNet partners is valid at the time of issue of this certificate. Updated information is available under www.iqnet-certification.com



RINA
www.rina.org

CERTIFICATO N. 2672/99/S
CERTIFICATE NO. 2672/99/S

SI CERTIFICA CHE IL SISTEMA DI GESTIONE PER LA QUALITÀ DI
IT IS HEREBY CERTIFIED THAT THE QUALITY MANAGEMENT SYSTEM OF

GART S.r.l.
VIA SAN BENEDETTO 95 36050 BRESSANVIDO (VI) ITALIA

NELLE SEGUENTI UNITÀ OPERATIVE / IN THE FOLLOWING OPERATIONAL UNITS

VIA SAN BENEDETTO 95 36050 BRESSANVIDO (VI) ITALIA

È CONFORME ALLA NORMA / IS IN COMPLIANCE WITH THE STANDARD
ISO 9001:2008

PER I SEGUENTI CAMPI DI ATTIVITÀ / FOR THE FOLLOWING FIELD(S) OF ACTIVITIES

PROGETTAZIONE, SVILUPPO, PRODUZIONE ED ASSISTENZA DI MOLLE AD ARIA ED ARTICOLI TECNICI IN GOMMA

DESIGN, DEVELOPMENT, MANUFACTURE AND TECHNICAL SERVICING OF AIR SPRINGS AND RUBBER ARTICLES

La validità del presente certificato è subordinata a sorveglianza periodica annuale / L'annualità del presente certificato è subordinata a sorveglianza periodica annuale / The validity of the certificate is dependent on an annual surveillance audit and on a complete review every three years of the management system. The use and validity of this certificate are subject to compliance with the RINA document: *Linee guida per la certificazione di Sistemi di Gestione per la Qualità* / *Guidelines for the certification of Quality Management Systems* / *Directeur della Divisione Certificazione*

Prima emissione / First Issue: 29.12.1999
Emissione corrente / Current Issue: 30.12.2011
Data scadenza / Expiry Date: 29.12.2014

RINA Services S.p.A.
Via Corsica 12 - 16128 Genova Italy

ACCREDITA

CISQ is a member of **IQNet**
www.iqnet-certification.com

Per informazioni sulla validità del certificato, visitate il sito www.rina.org

For information concerning validity of the certificate, you can visit the site www.rina.org

Referirsi al Manuale della Qualità per i dettagli delle esclusioni ai requisiti della norma

Reference is to be made to the Quality Manual for details regarding the exemptions from the requirements of the standard

CISQ è la Federazione Italiana di Organismi di Certificazione dei sistemi di gestione aziendale

CISQ is the Italian Federation of management system Certification Bodies.



IDENTIFICAZIONE DELLE MOLLE AD ARIA

Ogni molla ad aria GART è identificata con il tipo e il numero di codice.

Il tipo identifica la membrana di gomma, ed è stampigliato sulla membrana stessa.

Il codice identifica le diverse versioni fornite, quindi per ogni tipo di membrana possono esistere diversi codici. Per questo bisogna sempre specificare il tipo indicato sulla membrana e il codice.

ESEMPIO:	TIPO	CODICE
	T271	271.3.290
	T271	271.3.295
	D278/E	278.2.430
	D278/E	278.2.432

IDENTIFICATION OF AIR SPRINGS

Every airspring GART is identify with a type and a code.

The type identify the bellow of rubber and it is stamped on the bellow.

The code identify the different kind of versions,so for a single type could be different codes.

For that reason you have to specify always the type of the bellow and the code.





Example:	TYPE	CODE
	T271	271.3.290
	T271	271.3.295
	D278/E	278.2.430
	D278/E	278.2.432

Nonostante la cura e l'attenzione impiegata per la stesura del presente catalogo possiamo essere incorsi in qualche involontario errore. Ci scusiamo anticipatamente e Vi preghiamo di darne cortese comunicazione.

We take the maximun care in making this catalogue, but some mistake could be involuntary done. If so, we sorry about that, and we will be very grateful if you will comunicate us.







PROBLEMI, CAUSE , SOLUZIONI
PROBLEMS, CAUSES, SOLUTIONS

Problema		FOTO	PHOTOS	Problem	
Causa	Soluzione			Cause	Solution
Rottura viti filettate				Broken off thread bolts	
<ul style="list-style-type: none"> - coppia di serraggio eccessiva - utilizzo di olii o lubrificanti 	<ul style="list-style-type: none"> - rispetto della coppia di serraggio raccomandata - evitare l'uso di olii o lubrificanti - utilizzo della chiave dinamometrica 			<ul style="list-style-type: none"> - excessive torque - use of oils or lubricants 	<ul style="list-style-type: none"> - respect recommended torque - avoid usage of oils or lubricants - use the torque wrench
Extracorsa				Overextension	
<ul style="list-style-type: none"> - errata regolazione della valvola di livellamento - corsa della molla non limitata - errata applicazione per la molla ad aria 	<ul style="list-style-type: none"> - controllare e correggere il livello della valvola di livellamento - controllare l'ammortizzatore - controllare la corretta applicazione della molla ad aria 			<ul style="list-style-type: none"> - incorrectly adjusted level control - spring travel not restricted - air spring not suitable for application 	<ul style="list-style-type: none"> - check and adjust level control valve - check the shock absorber - check if the air spring fits the correct code
Abrasion				Abrasion	
<ul style="list-style-type: none"> - contatto delle membrana con parti del chassis - contatto della membrana con corpi estranei 	<ul style="list-style-type: none"> - controllare la corretta applicazione della molla ad aria - rimuovere gli oggetti esterni tra la membrana e il pistone 			<ul style="list-style-type: none"> - contact with chassis parts - contact with foreign bodies 	<ul style="list-style-type: none"> - check if air spring fits the correct code - remove foreign object stuck between bellows and piston
Molla ad aria scoppiata				Air spring bursting	
<ul style="list-style-type: none"> - sovraccarico - utilizzo oltre la pressione massima consentita 	<ul style="list-style-type: none"> - Non oltre oltrepassare mai il massimo carico consentito - Non oltrepassare la pressione massima consentita 			<ul style="list-style-type: none"> - exceedig the maximun allowable pressure - overload 	<ul style="list-style-type: none"> - do not exceed the maximal allowed weight of the vehicle



PROBLEMI, CAUSE , SOLUZIONI
PROBLEMS, CAUSES, SOLUTIONS

Problema		FOTO	PHOTOS	Problem	
Causa	Soluzione			Cause	Solution
Pistone rotto, membrana tagliata				Broken piston, cut bellow	
<ul style="list-style-type: none"> - sovraccarico - utilizzo oltre la corsa minima consentita - utilizzo oltre la capacità angolare consentita 	<ul style="list-style-type: none"> - Non oltre oltrepassare mai il massimo carico consentito 			<ul style="list-style-type: none"> - overload - exceeding the minimum allowable height - exceeding angular capability 	<ul style="list-style-type: none"> - never exceed the maximal allowed weight
Pistone rotto, membrana tagliata				Broken piston, cut bellow	
<ul style="list-style-type: none"> - sovraccarico - utilizzo oltre la corsa minima consentita - utilizzo oltre la capacità angolare consentita 	<ul style="list-style-type: none"> - Non oltre oltrepassare mai il massimo carico consentito 			<ul style="list-style-type: none"> - overload - exceeding the minimum allowable height - exceeding angular capability 	<ul style="list-style-type: none"> - never exceed the maximal allowed weight
Rottura membrana				Broken bellow	
<ul style="list-style-type: none"> - utilizzo oltre la corsa minima consentita 	<ul style="list-style-type: none"> - non oltre oltrepassare mai il massimo carico consentito - controllare il fine corsa esterno 			<ul style="list-style-type: none"> - exceedig the minimum allowable height - spring travel not restricted 	<ul style="list-style-type: none"> - never exceed the maximal allowed weight - check external bumper
Movimentazione errata				Improper handling	
<ul style="list-style-type: none"> - immagazzinamento improprio - trasporto improprio 	<ul style="list-style-type: none"> - Immagazzinare luogo asciutto, privo di luce, temperatura normale - Evitare un errato trasporto 			<ul style="list-style-type: none"> - improper storage - improper transport 	<ul style="list-style-type: none"> - storage at no daylight, dry at normal room temperature - avoid improper transport
Movimentazione errata				Improper handling	
<ul style="list-style-type: none"> - immagazzinamento improprio - trasporto improprio 	<ul style="list-style-type: none"> - Immagazzinare luogo asciutto, privo di luce, temperatura normale - Evitare un errato trasporto 			<ul style="list-style-type: none"> - improper storage - improper transport 	<ul style="list-style-type: none"> - storage at no daylight, dry at normal room temperature - avoid improper transport



ELENCO ARTICOLI ARTICLES LIST

Codice / Code	Tipo / Type	Pagina / Page	Codice / Code	Tipo / Type	Pagina / Page	Codice / Code	Tipo / Type	Pagina / Page
271.2.200	T271/2	13	276.0.391	D276/BS	121	277.4.505	D277	36
271.2.201	T271/2	13	276.0.420	D276	119	277.4.505/1	D277 NEW	36
271.2.204	T271/2	14	276.0.480	D276/L	123	277.4.505/2	D277 NEW	37
271.2.252	T271/2C	14	276.1.261	D276/DR	29	277.4.506	D277	37
271.2.253	T271/2C	14	276.1.264	D276/DR	29	277.4.507	D277	38
271.3.290	T271	12	276.1.371	D276/CR	28	277.4.508	D277	39
271.3.293	T271	12	276.1.372	D276/CR	28	277.4.520	D277/D	44
271.3.294	T271/S	15	276.1.420	D276/R	31	277.4.521	D277/DA	44
271.3.295	T271	12	276.1.421	D276/R	31	277.4.523	D277/DA	45
271.3.296	T271/S	15	276.1.423	D276/R	32	277.4.524	D277/D	44
271.3.298	T271/S	15	276.1.428	D276/R	32	278.0.270	D278/C	124
271.3.298/1	T271/S	16	276.1.480	D276/LR	29	278.0.355	D278/B	124
271.3.298/2	T271/S	16	276.1.481	D276/LR	30	278.0.421	D278/G	50
272.0.199	T272/N	17	276.1.482	D276/LR	30	278.0.430	D278	124
272.2.190	T272/N	17	276.1.486	D276/LR	30	278.0.434	D278/R	58
272.2.220	T272/H	16	276.1.487	D276/LR	31	278.0.451	D278/S	59
274.0.310	T274/B	19	276.2.421	D276/R-	32	278.0.452	D278/S	59
274.2.210	T274	17	277.0.424	D277/B	39	278.0.471	D278/V	63
274.2.214	T274	18	277.0.504	D277	33	278.0.511	D278/H	51
274.2.270	T274/C	19	277.1.505	D277 NEW	33	278.0.531	D278/HS	55
274.2.310	T274/B	19	277.2.420	D277/B	39	278.1.355	D278/V1	64
274.3.300	T274/3	18	277.2.421	D277/B	40	278.1.430	D278/R	59
274.3.311	T274/3H	18	277.2.422	D277/B NEW	40	278.1.452	D278/S NEW	60
275.1.120	T275	20	277.2.500	D277/2F	33	278.1.453	D278/S NEW	60
275.1.124	T275	20	277.2.503	D277	34	278.1.454	D278/S NEW	60
275.1.170	T275/B	20	277.2.504	D277	34	278.1.455	D278/S	61
275.1.171	T275/B	21	277.2.520	D277/D	43	278.1.470	D278/V	63
275.1.180	T275/F	21	277.4.420	D277/B	41	278.1.510	D278/H	52
275.1.184	T275/F	21	277.4.422	D277/B NEW	41	278.1.511	D278/H	52
276.0.260	D276/D	122	277.4.423	D277/B	42	278.1.530	D278/HS	56
276.0.262	D276/DS NEW	122	277.4.424	D277/B	42	278.1.530/1	D278/HS NEW	56
276.0.300	D276/F	123	277.4.424/1	D277/B NEW	42	278.2.300	D278/NA	57
276.0.301	D276/FS NEW	123	277.4.425/1	D277/B	43	278.2.300/1	D278/NA NEW	57
276.0.330	D276/E	122	277.4.500	D277	35	278.2.330	D278/N	58
276.0.370	D276/C	121	277.4.501	D277/C	43	278.2.330/1	D278/N NEW	58
276.0.390	D276/B	120	277.4.504	D277	36	278.2.340	D278/EB	47



ELENCO ARTICOLI ARTICLES LIST

Codice / Code	Tipo / Type	Pagina / Page	Codice / Code	Tipo / Type	Pagina / Page	Codice / Code	Tipo / Type	Pagina / Page
278.2.341	D278/EB	47	279.1.153	T279/E	23	287.2.510	D287/A	71
278.2.342	D278/EB	48	279.1.195	T279/L	23	287.2.580	D287/B NEW	72
278.2.401	D278/EC	48	279.2.154	T279	22	287.2.670	D287/D	75
278.2.415	D278/MA	57	279.2.174	T279/B	22	287.4.510	D287/A	71
278.2.422	D278/G	50	281.2.190	T281	24	287.4.512	D287/A	71
278.2.430	D278/E	45	282.0.460	C282/C	66	287.4.520	D287	70
278.2.432	D278/E	46	282.0.461	C282/C	66	287.4.521	D287	70
278.2.433	D278/E	46	282.0.601	C282/H	67	287.4.522	D287	70
278.2.437	D278/E	46	282.1.460	C282/C	67	287.4.540	D287/E NEW	77
278.2.439	D278/E	47	282.1.461	C282/C	67	287.4.580	D287/B	72
278.2.491	D278/FB	49	282.1.600	C282/H	68	287.4.581	D287/B	72
278.2.492	D278/FB NEW	49	282.2.432	C282/B	66	287.4.600	D287/C	74
278.2.500	D278/M	56	282.2.530	C282	64	287.4.601	D287/C	75
278.2.511	D278/H	52	282.2.533	C282	64	287.4.601/1	D287/C NEW	75
278.2.512	D278/H	53	282.2.535	C282	65	289.0.300	C289/B	126
278.2.515	D278/H	53	282.2.537	C282	65	289.0.301	C289/BS	126
278.2.520	D278/F	48	282.4.532	C282	65	289.0.350	C289	125
278.2.522	D278/F	49	286.0.420	D286	125	289.0.360	C289/E	127
278.4.421	D278/G	50	286.0.550	D286/B	125	289.0.400	C289/D	127
278.4.421/1	D278/G NEW	51	286.2.420	D286	68	289.0.411	C289/M1 NEW	79
278.4.422	D278/G	51	286.2.421	D286	68	289.0.450	C289/C	126
278.4.451	D278/S	61	286.2.422	D286 NEW	69	289.0.455	C289/C1 NEW	127
278.4.452	D278/S	61	286.2.423	D286 NEW	69	289.0.460	C289/G NEW	128
278.4.453	D278/S	62	287.0.521	D287	69	289.0.512	C289/M	78
278.4.454	D278/S	62	287.0.541	D287/E	76	289.1.410	C289/M1 NEW	80
278.4.454/1	D278/S	62	287.0.601	D287/C	73	289.1.510	C289/M	79
278.4.456	D278/S NEW	63	287.0.603	D287/H	77	289.1.513	C289/M NEW	79
278.4.511	D278/H	53	287.1.480	D287/SC NEW	78	290.0.340	D290/E	129
278.4.511/1	D278/H NEW	54	287.1.540	D287/E	76	290.0.390	D290/B	128
278.4.512	D278/H	54	287.1.541	D287/E NEW	76	290.0.392	D290/BR NEW	83
278.4.514	D278/H	54	287.1.542	D287/E NEW	77	290.0.393	D290/BR NEW	83
278.4.516	D278/H	55	287.1.600	D287/C	73	290.0.394	D290/BR NEW	84
278.4.517	D278/H1 NEW	55	287.1.602	D287/C NEW	73	290.0.395	D290/BR NEW	84
278.4.535	D278/D NEW	45	287.1.603	D287/C NEW	74	290.0.420	D290	128
279.1.090	T279/C	22	287.1.604	D287/C NEW	74	290.0.440	D290/C	129
279.1.120	T279/F	23	287.1.606	D287/H	78	290.0.480	D290/D	129



ELENCO ARTICOLI ARTICLES LIST

Codice / Code	Tipo / Type	Pagina / Page	Codice / Code	Tipo / Type	Pagina / Page	Codice / Code	Tipo / Type	Pagina / Page
290.0.555	D290/F	NEW 130	292.2.462	C292/A	88	294.1.450	C294	99
290.1.390	D290/BR	84	292.2.530	C292	87	294.1.451	C294	99
290.1.391	D290/BR	85	292.2.531	C292	87	294.1.452	C294	100
290.1.392	D290/BR	85	292.2.532	C292	87	294.1.500	C294/HS	102
290.1.393	D290/BR	85	292.2.600	C292/B	NEW 89	294.1.530	C294/C	NEW 101
290.1.394	D290/B	NEW 80	292.2.602	C292/B	NEW 90	294.2.450	C294	100
290.1.395	D290/B	NEW 81	293.0.411	C293/A	94	294.2.450/1	C294	NEW 100
290.1.396	D290/B	NEW 81	293.0.412	C293/A	94	294.2.451	C294	101
290.1.397	D290/B	NEW 81	293.0.413	C293/A	95	294.2.454	C294/D	NEW 102
290.1.398	D290/B	NEW 82	293.0.414	C293/A	95	294.2.460	C294/R	104
290.1.399	D290/B	NEW 82	293.0.461	C293/V	98	294.2.485	C294/S	104
290.1.420	D290	NEW 80	293.0.511	C293	91	294.2.501	C294/HS	NEW 103
290.2.340	D290/E	86	293.0.512	C293	91	294.2.502	C294/HS	NEW 103
290.2.341	D290/E	86	293.0.513	C293	92	295.1.400	C295/VA	107
290.2.390	D290/B	82	293.0.514	C293	92	295.1.465	C295/V	107
290.2.391	D290/B	83	293.0.611	C293/B	97	295.1.475	C295/SC	NEW 107
291.1.170	T291/B	27	293.1.460	C293/V	98	295.2.470	C295/B	106
291.2.200	T291/2	24	293.2.410	C293/A	95	295.2.510	C295	105
291.2.201	T291/2	24	293.2.412	C293/A	96	295.2.511	C295	106
291.2.202	T291/2	25	293.2.414	C293/A	96	295.2.512	C295	106
291.2.203	T291/2	25	293.2.414/PE	C293/A	96	296.0.340	D296/D	133
291.2.203/1	T291/2	NEW 25	293.2.415	C293/A	97	296.0.360	D296/C	132
291.2.260	T291/2B	26	293.2.510	C293	92	296.0.375	D296/B	132
291.2.262	T291/2B	26	293.2.512	C293	93	296.0.415	D296	132
291.2.263	T291/2B	NEW 26	293.2.513	C293	NEW 93	296.1.340	D296/D	108
292.0.380	C292/C	130	293.2.514	C293	93	296.1.341	D296/D	NEW 108
292.0.450	C292/D	131	293.2.514/PE	C293	94	297.0.390	D297	133
292.0.461	C292/A	88	293.2.612	C293/B	97	297.1.300	D297/C	111
292.0.520	C292/E	131	294.0.431	C294/V	104	297.1.300/1	D297/C	NEW 111
292.0.531	C292	86	294.0.451	C294	98	297.1.430	D297/B	109
292.0.533	C292/S	90	294.0.453	C294	99	297.1.430/1	D297/B	NEW 109
292.0.601	C292/B	89	294.0.455	C294/D	NEW 102	297.1.431	D297/B	110
292.1.533	C292/S	90	294.0.461	C294/R	NEW 103	297.1.431/1	D297/B	NEW 110
292.1.534	C292/S	91	294.0.531	C294/C	NEW 101	297.1.432	D297/B	110
292.2.460	C292/A	88	294.1.370	C294/VA	105	297.1.432/1	D297/B	NEW 111
292.2.460/1	C292/AR	89	294.1.430	C294/V	105	297.2.315	D297/A	108



ELENCO ARTICOLI ARTICLES LIST

Codice / Code	Tipo / Type	Pagina / Page	Codice / Code	Tipo / Type	Pagina / Page	Codice / Code	Tipo / Type	Pagina / Page
297.2.315/1	D297/A	NEW 109	305.0.320	D305	137			
298.0.355	D298/E	135	306.1.420	D306/A	119			
298.0.385	D298/D	135	306.2.320	D306	119			
298.0.460	D298/C	134						
298.0.515	D298/B	134						
298.0.620	D298	134						
299.0.450	C299	135						
299.0.460	C299/A	112						
299.0.461	C299/A	112						
299.0.490	C299/E	136						
299.1.460	C299/A	112						
299.1.461	C299/A	113						
300.0.070	T300/1	27						
300.0.131	T300/2	28						
300.0.191	T300	27						
301.0.235	C301/B	136						
301.0.330	C301	136						
302.0.376	C302	113						
302.0.376/2	C302	113						
302.0.385	C302/A	137						
302.0.521	C302/B	114						
302.1.375	C302	114						
302.1.375/2	C302	114						
302.1.520	C302/B	115						
302.1.521	C302/B	115						
304.0.440	C304	115						
304.0.441	C304	116						
304.0.490	C304/B	137						
304.0.511	C304/M4	118						
304.0.513	C304/M3	117						
304.1.440	C304	116						
304.1.441	C304	116						
304.1.443	C304	117						
304.1.444	C304	117						
304.1.510	C304/M4	118						
304.1.513	C304/M3	118						



TIPO - TYPE	CODICE - CODE	RIFERIMENTO ORIGINALE - O. E. REFERENCE														
<p>T271</p>	<p>271.3.290</p>	<table border="1"> <tr><td>99381003</td><td>AUSTERAS</td></tr> <tr><td>0.41.04.003.0</td><td>B.P.W.</td></tr> <tr><td>05.050.0300</td><td>CAMPANA</td></tr> <tr><td>05101501</td><td>S.T. SYSTEM TRUCK</td></tr> <tr><td>03003000010</td><td>TRAS CAR</td></tr> <tr><td>128118103</td><td>VIBERTI</td></tr> <tr><td>1006506</td><td>ZORZI</td></tr> </table>	99381003	AUSTERAS	0.41.04.003.0	B.P.W.	05.050.0300	CAMPANA	05101501	S.T. SYSTEM TRUCK	03003000010	TRAS CAR	128118103	VIBERTI	1006506	ZORZI
99381003	AUSTERAS															
0.41.04.003.0	B.P.W.															
05.050.0300	CAMPANA															
05101501	S.T. SYSTEM TRUCK															
03003000010	TRAS CAR															
128118103	VIBERTI															
1006506	ZORZI															
<p>T271</p>	<p>271.3.293</p>	<table border="1"> <tr><td>91621322</td><td>BARTOLETTI</td></tr> <tr><td>42107595</td><td>IVECO</td></tr> <tr><td>1006505</td><td>ZORZI</td></tr> </table>	91621322	BARTOLETTI	42107595	IVECO	1006505	ZORZI								
91621322	BARTOLETTI															
42107595	IVECO															
1006505	ZORZI															
<p>T271</p>	<p>271.3.295</p>	<table border="1"> <tr><td>20.38.1500.0</td><td>GIRELLI</td></tr> <tr><td>05101505</td><td>S.T. SYSTEM TRUCK</td></tr> </table>	20.38.1500.0	GIRELLI	05101505	S.T. SYSTEM TRUCK										
20.38.1500.0	GIRELLI															
05101505	S.T. SYSTEM TRUCK															

I nominativi dei costruttori e i relativi riferimenti originali citati nel presente catalogo sono riportati a puro titolo indicativo. I nostri prodotti non sono originali ma con essi intercambiabili.
The name of manufacturers and the o.e. references mentioned in this catalogue are given for cross-reference purposes only. Our products are not original but interchangeable with.

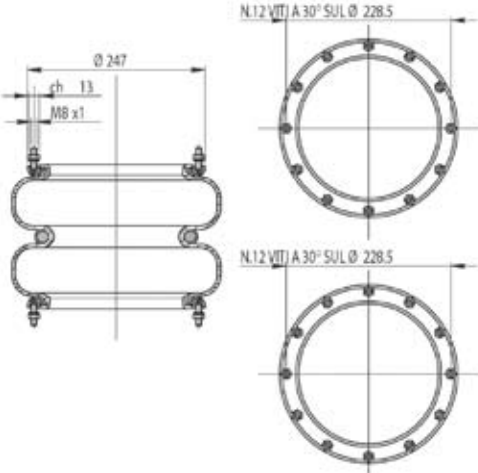
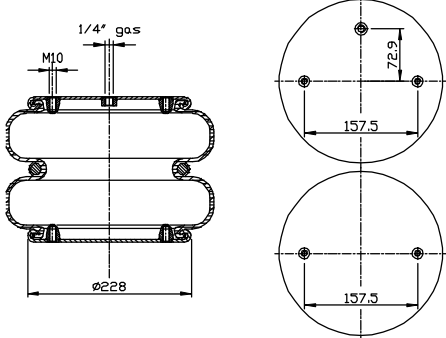

TIPO - TYPE	CODICE - CODE	RIFERIMENTO ORIGINALE - O. E. REFERENCE	
<p>T271/2</p> 	<p>271.2.200</p>	<p>10902700</p> <p>02.200.21.90.0</p> <p>91621022</p> <p>831120120</p> <p>546905134</p> <p>831120120</p> <p>-</p> <p>590530</p> <p>NA 1816</p> <p>98460983</p> <p>3452571</p> <p>81.43601.0022</p> <p>05101510</p> <p>3229100100</p> <p>3228100100</p> <p>2229100100</p> <p>9534175010</p> <p>9534175020</p> <p>-</p> <p>-</p>	<p>ADIGE</p> <p>B. P. W.</p> <p>BARTOLETTI</p> <p>BREDAMENARINIBUS</p> <p>BUSSING</p> <p>BUSSING</p> <p>FRANCHIN</p> <p>GIRELLI</p> <p>HENDRICKSON</p> <p>IVECO</p> <p>MAGIRUS DEUTZ</p> <p>MAN</p> <p>S.T. SYSTEM TRUCK</p> <p>SAF</p> <p>SAF</p> <p>SAF</p> <p>SAURER</p> <p>SAURER</p> <p>SICAS</p> <p>SPECIALCAR - WEGA</p>
<p>T271/2</p> 	<p>271.2.201</p>	<p>-</p>	<p>MINONZIO</p>

I nominativi dei costruttori e i relativi riferimenti originali citati nel presente catalogo sono riportati a puro titolo indicativo. I nostri prodotti non sono originali ma con essi intercambiabili.
 The name of manufacturers and the o.e. references mentioned in this catalogue are given for cross-reference purposes only. Our products are not original but interchangeable with.



TIPO - TYPE	CODICE - CODE	RIFERIMENTO ORIGINALE - O. E. REFERENCE	
<p>T271/2</p>	<p>271.2.204</p>		
		112186	ROLFO
		2229100100	SAF
<p>T271/2C</p>	<p>271.2.252</p>		
		99381019	AUSTERAS
<p>T271/2C</p>	<p>271.2.253</p>		
		99381035	AUSTERAS

I nominativi dei costruttori e i relativi riferimenti originali citati nel presente catalogo sono riportati a puro titolo indicativo. I nostri prodotti non sono originali ma con essi intercambiabili.
 The name of manufacturers and the o.e. references mentioned in this catalogue are given for cross-reference purposes only. Our products are not original but interchangeable with.



TIPO - TYPE	CODICE - CODE	RIFERIMENTO ORIGINALE - O. E. REFERENCE	
<p>T271/S</p>	<p>271.3.294</p>		
		-	BOSSINI
		128118107	VIBERTI
		-	WEWELER
<p>T271/S</p>	<p>271.3.296</p>		
		99381041	AUSTERAS
<p>T271/S</p>	<p>271.3.298</p>		
		112321	ROLFO

I nominativi dei costruttori e i relativi riferimenti originali citati nel presente catalogo sono riportati a puro titolo indicativo. I nostri prodotti non sono originali ma con essi intercambiabili.
 The name of manufacturers and the o.e. references mentioned in this catalogue are given for cross-reference purposes only. Our products are not original but interchangeable with.



TIPO - TYPE	CODICE - CODE	RIFERIMENTO ORIGINALE - O. E. REFERENCE	
<p>T271/S</p>	<p>271.3.298/1</p>		
		58053200	CARDI
		112273	ROLFO
<p>T271/S</p>	<p>271.3.298/2</p>		
		112323	ROLFO
<p>T272/H</p>	<p>272.2.220</p>		FRANCHIN

I nominativi dei costruttori e i relativi riferimenti originali citati nel presente catalogo sono riportati a puro titolo indicativo. I nostri prodotti non sono originali ma con essi intercambiabili.
 The name of manufacturers and the o.e. references mentioned in this catalogue are given for cross-reference purposes only. Our products are not original but interchangeable with.



TIPO - TYPE	CODICE - CODE	RIFERIMENTO ORIGINALE - O. E. REFERENCE	
T272/N	272.0.199		
		02.200.20.80.0	B.P.W.
		03422652	MAGIRUS DEUTZ
T272/N	272.2.190		
		-	AUTONEGOZIO AUTOMARKET BARIBBI
		-	FRANCHIN SPECIAL CAR
		-	MINONZIO
		03003000090	TRAS CAR
		1006500	ZORZI
T274	274.2.210		
		99381024	AUSTERAS
		0.41.04.004.0	B.P.W.
		05.050.0400	CAMPANA
		58053300	CARDI
		8194819	IVECO
		8194818	IVECO
		21225697	ROR - MERITOR
		03003000020	TRAS CAR
		128118102	VIBERTI

I nominativi dei costruttori e i relativi riferimenti originali citati nel presente catalogo sono riportati a puro titolo indicativo. I nostri prodotti non sono originali ma con essi intercambiabili.
 The name of manufacturers and the o.e. references mentioned in this catalogue are given for cross-reference purposes only. Our products are not original but interchangeable with.

TIPO - TYPE	CODICE - CODE	RIFERIMENTO ORIGINALE - O. E. REFERENCE
<p>T274</p>	<p>274.2.214</p>	<p>11041022 TECMA</p>
<p>T274/3</p>	<p>274.3.300</p>	<p>- BERTOJA - ZORZI</p>
<p>T274/3HS</p>	<p>274.3.311</p>	<p>- BOSSINI</p>

I nominativi dei costruttori e i relativi riferimenti originali citati nel presente catalogo sono riportati a puro titolo indicativo. I nostri prodotti non sono originali ma con essi intercambiabili.
The name of manufacturers and the o.e. references mentioned in this catalogue are given for cross-reference purposes only. Our products are not original but interchangeable with.



TIPO - TYPE	CODICE - CODE	RIFERIMENTO ORIGINALE - O. E. REFERENCE	
T274/B	274.0.310	4731034200	KAESSBOHRER
T274/B	274.2.310	99381015	AUSTERAS
		22.114.07	BATTAGLINO
		-	BOSSINI
		58053100	CARDI
		42107588	IVECO
		4731034200	KAESSBOHRER
		4731018000	KAESSBOHRER
		05101522	S.T. SYSTEM TRUCK
		1006509	ZORZI
T274/C	274.2.270	99381007	AUSTERAS
		22.068.00	BATTAGLINO
		58053100	CARDI
		42126126	IVECO
		42107588	IVECO
		112007	ROLFO
		05101520	S.T. SYSTEM TRUCK
		03003000030	TRAS CAR

I nominativi dei costruttori e i relativi riferimenti originali citati nel presente catalogo sono riportati a puro titolo indicativo. I nostri prodotti non sono originali ma con essi intercambiabili.
 The name of manufacturers and the o.e. references mentioned in this catalogue are given for cross-reference purposes only. Our products are not original but interchangeable with.

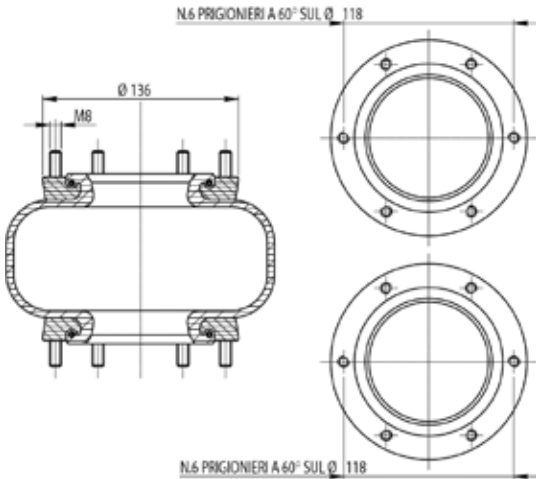
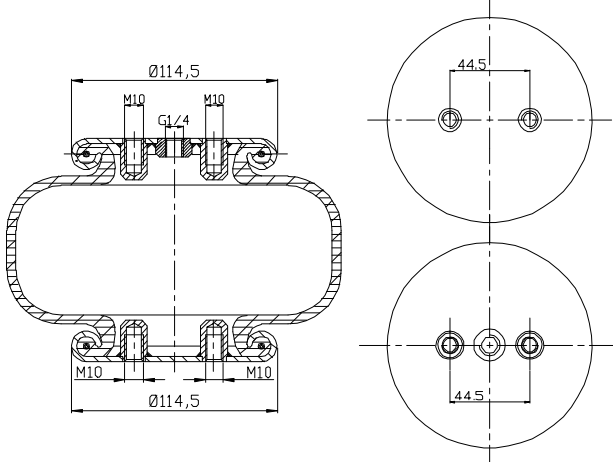
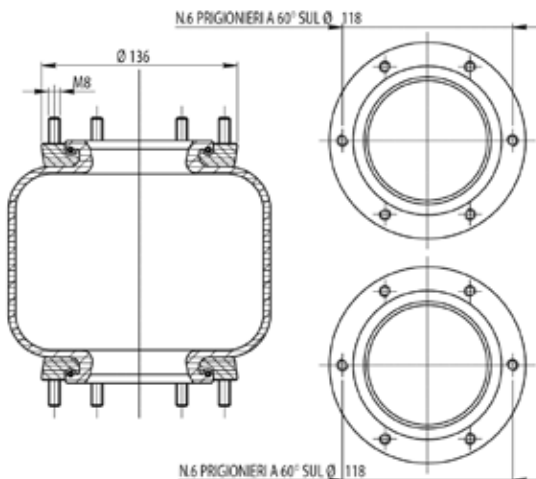

TIPO - TYPE	CODICE - CODE	RIFERIMENTO ORIGINALE - O. E. REFERENCE																
<p>T275</p> 	<p>275.1.120</p>	<table border="1"> <tr><td>M19141000</td><td>ASSALI STEFEN</td></tr> <tr><td>99381001</td><td>AUSTERAS</td></tr> <tr><td>91621110</td><td>BARTOLETTI</td></tr> <tr><td>22.070.00</td><td>BATTAGLINO</td></tr> <tr><td>21212549</td><td>ROR - MERITOR</td></tr> <tr><td>F3034A</td><td>SANSAVINI</td></tr> <tr><td>03003000040</td><td>TRAS CAR</td></tr> <tr><td>1006508</td><td>ZORZI</td></tr> </table>	M19141000	ASSALI STEFEN	99381001	AUSTERAS	91621110	BARTOLETTI	22.070.00	BATTAGLINO	21212549	ROR - MERITOR	F3034A	SANSAVINI	03003000040	TRAS CAR	1006508	ZORZI
M19141000	ASSALI STEFEN																	
99381001	AUSTERAS																	
91621110	BARTOLETTI																	
22.070.00	BATTAGLINO																	
21212549	ROR - MERITOR																	
F3034A	SANSAVINI																	
03003000040	TRAS CAR																	
1006508	ZORZI																	
<p>T275</p> 	<p>275.1.124</p>	<table border="1"> <tr><td>-</td><td>ZORZI</td></tr> </table>	-	ZORZI														
-	ZORZI																	
<p>T275/B</p> 	<p>275.1.170</p>	<table border="1"> <tr><td>22.070.05</td><td>BATTAGLINO</td></tr> </table>	22.070.05	BATTAGLINO														
22.070.05	BATTAGLINO																	

I nominativi dei costruttori e i relativi riferimenti originali citati nel presente catalogo sono riportati a puro titolo indicativo. I nostri prodotti non sono originali ma con essi intercambiabili.
 The name of manufacturers and the o.e. references mentioned in this catalogue are given for cross-reference purposes only. Our products are not original but interchangeable with.



TIPO - TYPE	CODICE - CODE	RIFERIMENTO ORIGINALE - O. E. REFERENCE	
<p>T275/B</p>	<p>275.1.171</p>	<p>11041002</p>	<p>TECMA</p>
<p>T275/F</p>	<p>275.1.180</p>	<p>0.40.19.000.0 21223346</p>	<p>B.P.W. ROR - MERITOR</p>
<p>T275/F</p>	<p>275.1.184</p>	<p>-</p>	<p>MICHIELETTO</p>

I nominativi dei costruttori e i relativi riferimenti originali citati nel presente catalogo sono riportati a puro titolo indicativo. I nostri prodotti non sono originali ma con essi intercambiabili.
 The name of manufacturers and the o.e. references mentioned in this catalogue are given for cross-reference purposes only. Our products are not original but interchangeable with.

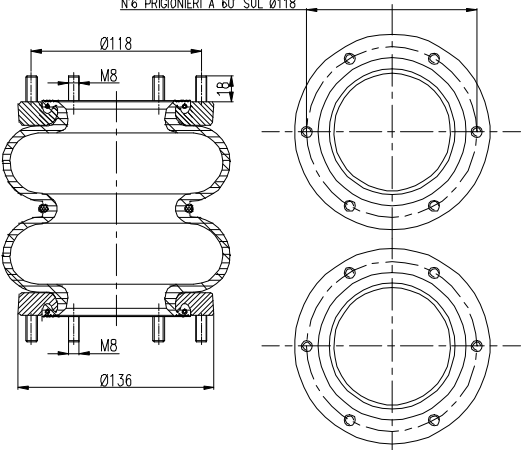
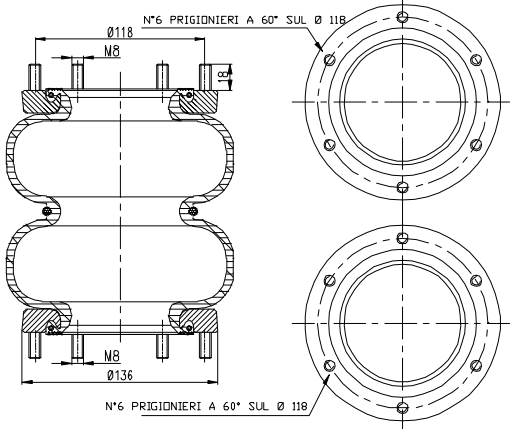
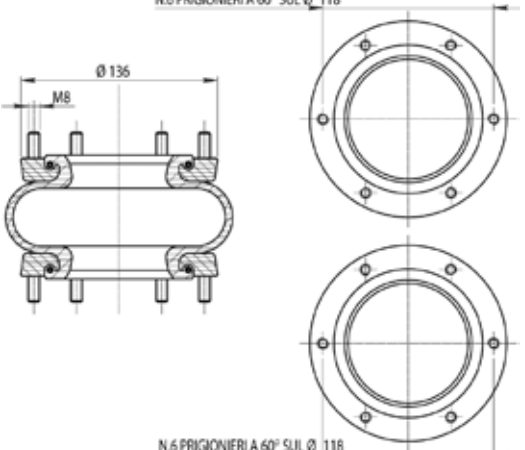
TIPO - TYPE	CODICE - CODE	RIFERIMENTO ORIGINALE - O. E. REFERENCE
<p>T279</p> 	<p>279.2.154</p>	<p>- -</p>
<p>T279/B</p> 	<p>279.2.174</p>	<p>99381014 AUSTERAS</p>
<p>T279/C</p> 	<p>279.1.090</p>	<p>- -</p>

I nominativi dei costruttori e i relativi riferimenti originali citati nel presente catalogo sono riportati a puro titolo indicativo. I nostri prodotti non sono originali ma con essi intercambiabili.
 The name of manufacturers and the o.e. references mentioned in this catalogue are given for cross-reference purposes only. Our products are not original but interchangeable with.

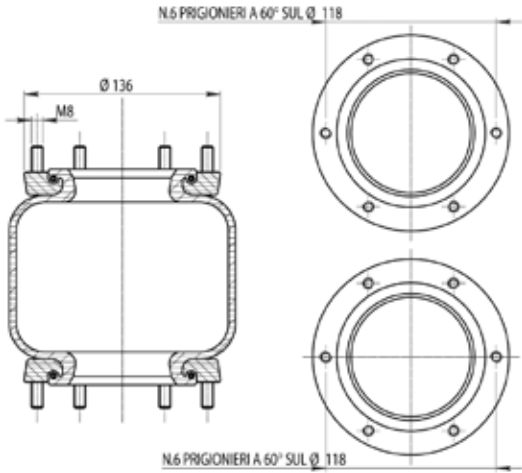
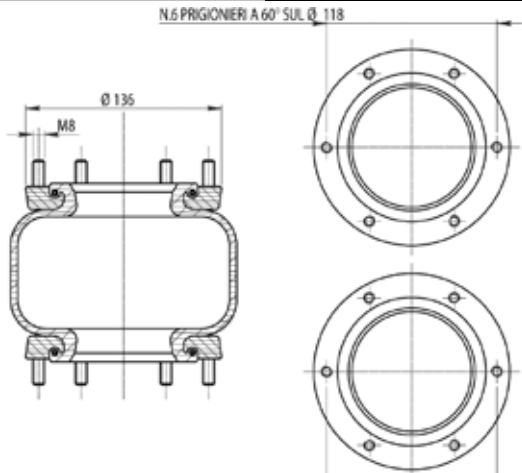
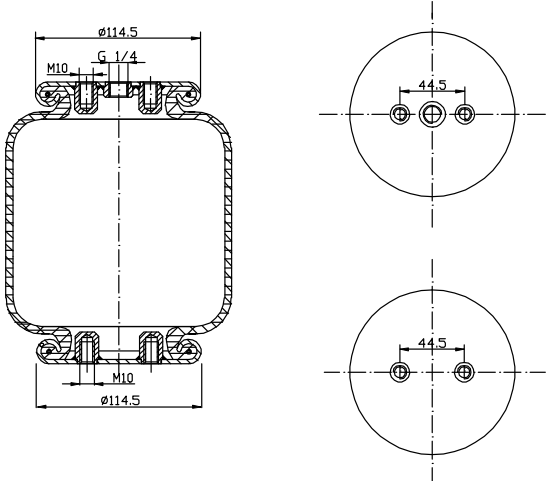

TIPO - TYPE	CODICE - CODE	RIFERIMENTO ORIGINALE - O. E. REFERENCE	
<p>T279/E</p> 	<p>279.1.153</p>	-	-
<p>T279/F</p> 	<p>279.1.120</p>	-	-
<p>T279/L</p> 	<p>279.1.195</p>	05101013	S.T. SYSTEM TRUCK

I nominativi dei costruttori e i relativi riferimenti originali citati nel presente catalogo sono riportati a puro titolo indicativo. I nostri prodotti non sono originali ma con essi intercambiabili.
 The name of manufacturers and the o.e. references mentioned in this catalogue are given for cross-reference purposes only. Our products are not original but interchangeable with.



TIPO - TYPE	CODICE - CODE	RIFERIMENTO ORIGINALE - O. E. REFERENCE	
<p>T281</p>	<p>281.2.190</p>	99381002	AUSTERAS
		196028	GIGANT
		42532991	IVECO
		81723192	LANCIA
<p>T291/2</p>	<p>291.2.200</p>	99381059	AUSTERAS
		15603	GRANNING
		1371	GRANNING
		NA1827	HENDRICKSON
		03234	MENCI
		21222663	ROR - MERITOR
		US 6910F	WEWELER
<p>T291/2</p>	<p>291.2.201</p>	81720882	LANCIA
		365461	VOLVO

I nominativi dei costruttori e i relativi riferimenti originali citati nel presente catalogo sono riportati a puro titolo indicativo. I nostri prodotti non sono originali ma con essi intercambiabili.
 The name of manufacturers and the o.e. references mentioned in this catalogue are given for cross-reference purposes only. Our products are not original but interchangeable with.

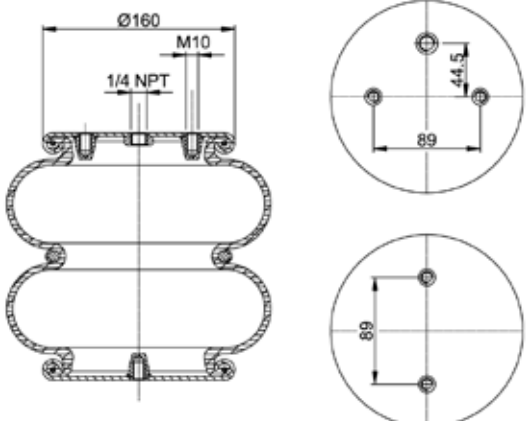
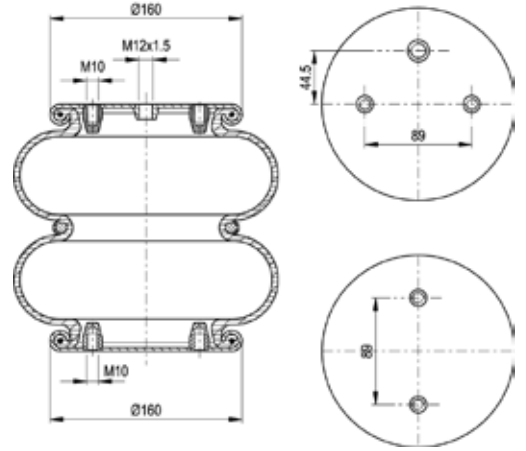
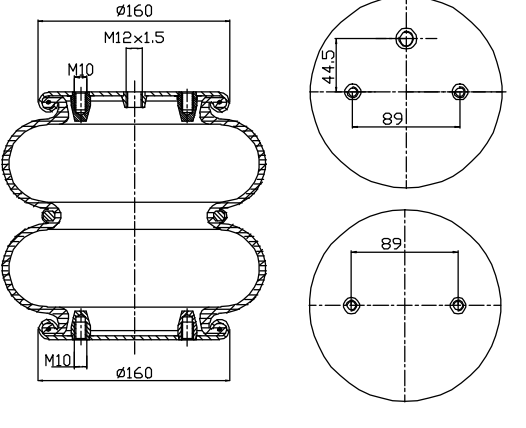

TIPO - TYPE	CODICE - CODE	RIFERIMENTO ORIGINALE - O. E. REFERENCE											
<p style="text-align: center;">T291/2</p> 	<p style="text-align: center;">291.2.202</p>	<table border="1" style="width: 100%;"> <tr> <td style="width: 50%;">03003000099</td> <td style="width: 50%;">TRAS CAR</td> </tr> </table>		03003000099	TRAS CAR								
03003000099	TRAS CAR												
<p style="text-align: center;">T291/2</p> 	<p style="text-align: center;">291.2.203</p>	<table border="1" style="width: 100%;"> <tr> <td style="width: 50%;">15599</td> <td style="width: 50%;">GRANNING</td> </tr> <tr> <td>6501706</td> <td>KOGEL</td> </tr> <tr> <td>4229100400</td> <td>SAF</td> </tr> <tr> <td>1387289</td> <td>SCANIA</td> </tr> <tr> <td>1319761</td> <td>SCANIA</td> </tr> </table>		15599	GRANNING	6501706	KOGEL	4229100400	SAF	1387289	SCANIA	1319761	SCANIA
15599	GRANNING												
6501706	KOGEL												
4229100400	SAF												
1387289	SCANIA												
1319761	SCANIA												
<p style="text-align: center;">T291/2</p> 	<p style="text-align: center;">291.2.203/1</p>	<p style="text-align: center;">NEW</p> <table border="1" style="width: 100%;"> <tr> <td style="width: 50%;">58053600</td> <td style="width: 50%;">CARDI</td> </tr> <tr> <td>112331</td> <td>ROLFO</td> </tr> </table>		58053600	CARDI	112331	ROLFO						
58053600	CARDI												
112331	ROLFO												

I nominativi dei costruttori e i relativi riferimenti originali citati nel presente catalogo sono riportati a puro titolo indicativo. I nostri prodotti non sono originali ma con essi intercambiabili.
 The name of manufacturers and the o.e. references mentioned in this catalogue are given for cross-reference purposes only. Our products are not original but interchangeable with.



TIPO - TYPE	CODICE - CODE	RIFERIMENTO ORIGINALE - O. E. REFERENCE														
<p>T291/2B</p>	<p>291.2.260</p>	<table border="1"> <tr><td>15670</td><td>GRANNING</td></tr> <tr><td>21221356</td><td>ROR - MERITOR</td></tr> <tr><td>05101512</td><td>S.T. SYSTEM TRUCK</td></tr> <tr><td>016808</td><td>SCHMITZ</td></tr> <tr><td>US 07394</td><td>WEWELER</td></tr> <tr><td>US 07394C</td><td>WEWELER</td></tr> <tr><td>US 07394F</td><td>WEWELER</td></tr> </table>	15670	GRANNING	21221356	ROR - MERITOR	05101512	S.T. SYSTEM TRUCK	016808	SCHMITZ	US 07394	WEWELER	US 07394C	WEWELER	US 07394F	WEWELER
15670	GRANNING															
21221356	ROR - MERITOR															
05101512	S.T. SYSTEM TRUCK															
016808	SCHMITZ															
US 07394	WEWELER															
US 07394C	WEWELER															
US 07394F	WEWELER															
<p>T291/2B</p>	<p>291.2.262</p>	<table border="1"> <tr><td>1319761</td><td>SAF</td></tr> <tr><td>1387283</td><td>SCANIA</td></tr> </table>	1319761	SAF	1387283	SCANIA										
1319761	SAF															
1387283	SCANIA															
<p>T291/2B</p>	<p>291.2.263</p>	<p>NEW</p> <table border="1"> <tr><td>4229100501</td><td>SAF</td></tr> <tr><td>4229100500</td><td>SAF</td></tr> </table>	4229100501	SAF	4229100500	SAF										
4229100501	SAF															
4229100500	SAF															

I nominativi dei costruttori e i relativi riferimenti originali citati nel presente catalogo sono riportati a puro titolo indicativo. I nostri prodotti non sono originali ma con essi intercambiabili.
The name of manufacturers and the o.e. references mentioned in this catalogue are given for cross-reference purposes only. Our products are not original but interchangeable with.

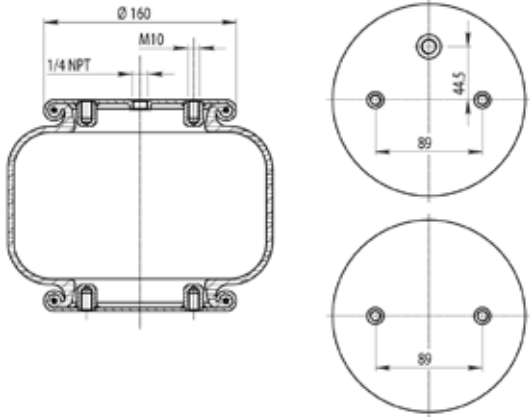
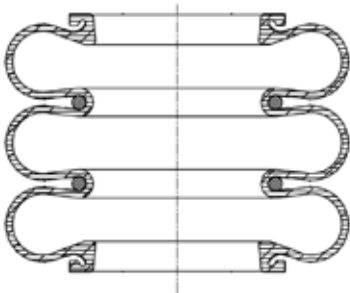
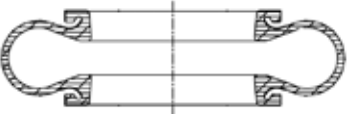

TIPO - TYPE	CODICE - CODE	RIFERIMENTO ORIGINALE - O. E. REFERENCE	
<p>T291/B</p> 	<p>291.1.170</p>		
		-	ASSALI STEFEN
		-	ROR - MERITOR
		05101010	S.T. SYSTEM TRUCK
<p>T300</p> 	<p>300.0.191</p>		
		-	-
<p>T300/1</p> 	<p>300.0.070</p>		
		-	-

I nominativi dei costruttori e i relativi riferimenti originali citati nel presente catalogo sono riportati a puro titolo indicativo. I nostri prodotti non sono originali ma con essi intercambiabili.
 The name of manufacturers and the o.e. references mentioned in this catalogue are given for cross-reference purposes only. Our products are not original but interchangeable with.

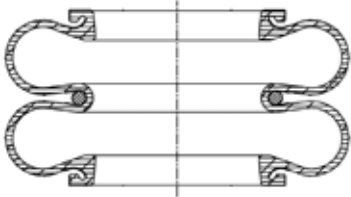
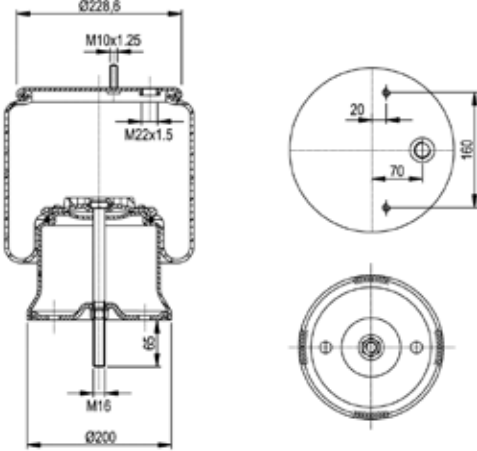
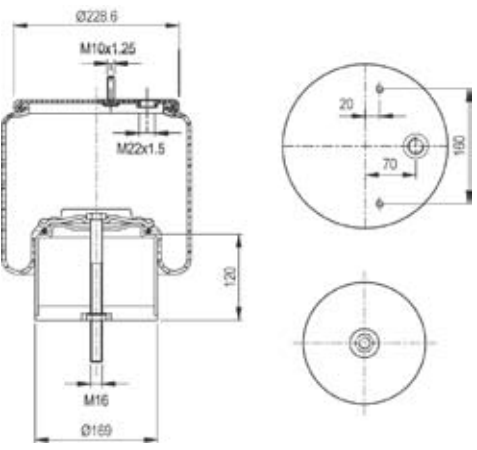

TIPO - TYPE	CODICE - CODE	RIFERIMENTO ORIGINALE - O. E. REFERENCE	
T300/2 	300.0.131	- -	
D276/CR 	276.1.371	0.41.03.015.0 B.P.W.	
D276/CR 	276.1.372	05101103 S.T. SYSTEM TRUCK 03003000065 TRAS CAR	

I nominativi dei costruttori e i relativi riferimenti originali citati nel presente catalogo sono riportati a puro titolo indicativo. I nostri prodotti non sono originali ma con essi intercambiabili.
 The name of manufacturers and the o.e. references mentioned in this catalogue are given for cross-reference purposes only. Our products are not original but interchangeable with.



TIPO - TYPE	CODICE - CODE	RIFERIMENTO ORIGINALE - O. E. REFERENCE	
<p>D276/DR</p>	<p>276.1.261</p>		
		010ML0020	MIELE
		05101005	S.T. SYSTEM TRUCK
		03003000000	TRAS CAR
<p>D276/DR</p>	<p>276.1.264</p>		
		05101102	S.T. SYSTEM TRUCK
<p>D276/LR</p>	<p>276.1.480</p>		
		99381010	AUSTERAS

I nominativi dei costruttori e i relativi riferimenti originali citati nel presente catalogo sono riportati a puro titolo indicativo. I nostri prodotti non sono originali ma con essi intercambiabili.
 The name of manufacturers and the o.e. references mentioned in this catalogue are given for cross-reference purposes only. Our products are not original but interchangeable with.



TIPO - TYPE	CODICE - CODE	RIFERIMENTO ORIGINALE - O. E. REFERENCE	
<p>D276/LR</p>	<p>276.1.481</p>	05101006	S.T. SYSTEM TRUCK
		03003000060	TRAS CAR
<p>D276/LR</p>	<p>276.1.482</p>	99381032	AUSTERAS
<p>D276/LRS</p>	<p>276.1.486</p>	99381027	AUSTERAS

I nominativi dei costruttori e i relativi riferimenti originali citati nel presente catalogo sono riportati a puro titolo indicativo. I nostri prodotti non sono originali ma con essi intercambiabili.
 The name of manufacturers and the o.e. references mentioned in this catalogue are given for cross-reference purposes only. Our products are not original but interchangeable with.

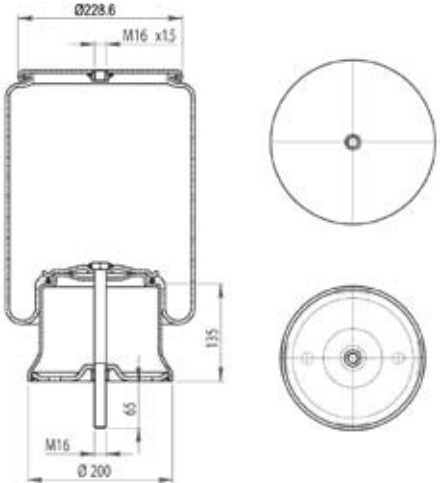
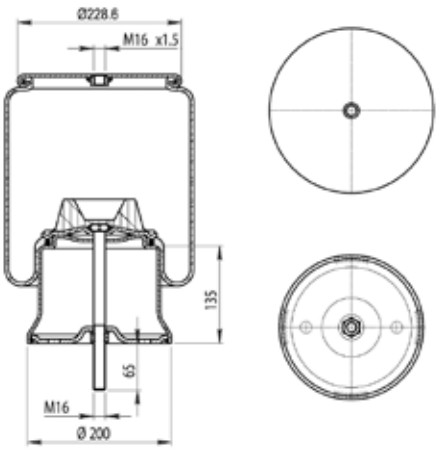
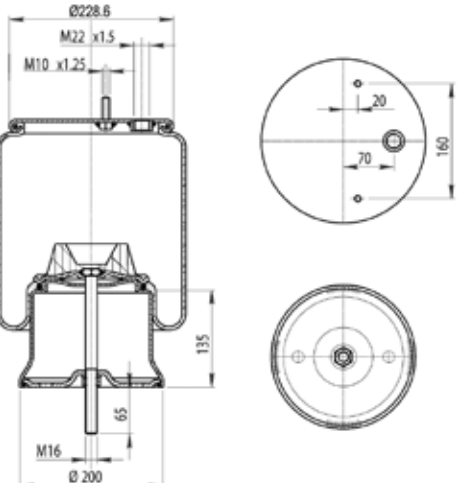

TIPO - TYPE	CODICE - CODE	RIFERIMENTO ORIGINALE - O. E. REFERENCE	
D276/LRS 	276.1.487	99381027	AUSTERAS
D276/R 	276.1.420	99381009	AUSTERAS
D276/R 	276.1.421	22.119.07	BATTAGLINO
		05.040.0200	CAMPANA
		03003000070	TRAS CAR

I nominativi dei costruttori e i relativi riferimenti originali citati nel presente catalogo sono riportati a puro titolo indicativo. I nostri prodotti non sono originali ma con essi intercambiabili.
 The name of manufacturers and the o.e. references mentioned in this catalogue are given for cross-reference purposes only. Our products are not original but interchangeable with.

TIPO - TYPE	CODICE - CODE	RIFERIMENTO ORIGINALE - O. E. REFERENCE
<p>D276/R</p>	<p>276.1.423</p>	<p>- ASSE SANSAVINI</p>
<p>D276/R</p>	<p>276.1.428</p>	<p>- ANDREOLI - AUSTERAS</p>
<p>D276/R-2F</p>	<p>276.2.421</p>	<p>22.119.00 BATTAGLINO</p>

I nominativi dei costruttori e i relativi riferimenti originali citati nel presente catalogo sono riportati a puro titolo indicativo. I nostri prodotti non sono originali ma con essi intercambiabili.
The name of manufacturers and the o.e. references mentioned in this catalogue are given for cross-reference purposes only. Our products are not original but interchangeable with.



TIPO - TYPE	CODICE - CODE	RIFERIMENTO ORIGINALE - O. E. REFERENCE															
<p style="text-align: center;">D277</p>	<p style="text-align: center;">277.0.504</p>	<p style="text-align: center;">-</p>															
<p style="text-align: center;">D277</p>	<p style="text-align: center;">277.1.505</p>	<p style="text-align: center;">NEW</p> <table border="1" style="width: 100%; border-collapse: collapse;"> <tr> <td style="width: 50%; text-align: center;">3228103100</td> <td style="width: 50%; text-align: center;">SAF</td> </tr> </table>		3228103100	SAF												
3228103100	SAF																
<p style="text-align: center;">D277/2F</p>	<p style="text-align: center;">277.2.500</p>	<table border="1" style="width: 100%; border-collapse: collapse;"> <tr> <td style="width: 50%; text-align: center;">58050700</td> <td style="width: 50%; text-align: center;">CARDI</td> </tr> <tr> <td style="text-align: center;">67306</td> <td style="text-align: center;">DAF</td> </tr> <tr> <td style="text-align: center;">-</td> <td style="text-align: center;">MISTRALL - BOLGAN</td> </tr> <tr> <td style="text-align: center;">11804</td> <td style="text-align: center;">OMAR</td> </tr> <tr> <td style="text-align: center;">112060</td> <td style="text-align: center;">ROLFO</td> </tr> <tr> <td style="text-align: center;">128147102</td> <td style="text-align: center;">VIBERTI</td> </tr> <tr> <td style="text-align: center;">1006553</td> <td style="text-align: center;">ZORZI</td> </tr> </table>		58050700	CARDI	67306	DAF	-	MISTRALL - BOLGAN	11804	OMAR	112060	ROLFO	128147102	VIBERTI	1006553	ZORZI
58050700	CARDI																
67306	DAF																
-	MISTRALL - BOLGAN																
11804	OMAR																
112060	ROLFO																
128147102	VIBERTI																
1006553	ZORZI																

I nominativi dei costruttori e i relativi riferimenti originali citati nel presente catalogo sono riportati a puro titolo indicativo. I nostri prodotti non sono originali ma con essi intercambiabili.
 The name of manufacturers and the o.e. references mentioned in this catalogue are given for cross-reference purposes only. Our products are not original but interchangeable with.



TIPO - TYPE	CODICE - CODE	RIFERIMENTO ORIGINALE - O. E. REFERENCE							
<p>D277</p>	<p>277.2.503</p>	<table border="1"> <tr> <td data-bbox="721 383 927 409">1006545</td> <td data-bbox="927 383 1444 409">ZORZI</td> </tr> </table>		1006545	ZORZI				
1006545	ZORZI								
<p>D277</p>	<p>277.2.504</p>	<table border="1"> <tr> <td data-bbox="721 947 927 974">128147124</td> <td data-bbox="927 947 1444 974">VIBERTI</td> </tr> <tr> <td data-bbox="721 974 927 1001">128147112</td> <td data-bbox="927 974 1444 1001">VIBERTI</td> </tr> <tr> <td data-bbox="721 1001 927 1028">1006565</td> <td data-bbox="927 1001 1444 1028">ZORZI</td> </tr> </table>		128147124	VIBERTI	128147112	VIBERTI	1006565	ZORZI
128147124	VIBERTI								
128147112	VIBERTI								
1006565	ZORZI								

I nominativi dei costruttori e i relativi riferimenti originali citati nel presente catalogo sono riportati a puro titolo indicativo. I nostri prodotti non sono originali ma con essi intercambiabili.
 The name of manufacturers and the o.e. references mentioned in this catalogue are given for cross-reference purposes only. Our products are not original but interchangeable with.



TIPO - TYPE	CODICE - CODE	RIFERIMENTO ORIGINALE - O. E. REFERENCE																																																																																
D277	277.4.500																																																																																	
		<table border="1"> <tbody> <tr><td>448543</td><td>ACERBI</td></tr> <tr><td>42402003</td><td>BERTOJA</td></tr> <tr><td>388491</td><td>DAF</td></tr> <tr><td>143908-3</td><td>ERF</td></tr> <tr><td>003615E</td><td>FRUEHAUF</td></tr> <tr><td>15634</td><td>GRANNING</td></tr> <tr><td>785170</td><td>HENDRICKSON</td></tr> <tr><td>Y505801</td><td>HENDRICKSON</td></tr> <tr><td>B 2063</td><td>HENDRICKSON</td></tr> <tr><td>505859</td><td>HENDRICKSON</td></tr> <tr><td>8121964</td><td>IVECO</td></tr> <tr><td>4731033000</td><td>KAESSBOHRER</td></tr> <tr><td>4731030000</td><td>KAESSBOHRER</td></tr> <tr><td>22282</td><td>NEWAY</td></tr> <tr><td>175005</td><td>PEGASO</td></tr> <tr><td>250991</td><td>PIACENZA</td></tr> <tr><td>21215633</td><td>ROR - MERITOR</td></tr> <tr><td>5000790692</td><td>RVI</td></tr> <tr><td>5010130925</td><td>RVI</td></tr> <tr><td>8403/102</td><td>SAE</td></tr> <tr><td>3229000300</td><td>SAF</td></tr> <tr><td>3229001800</td><td>SAF</td></tr> <tr><td>3228000300</td><td>SAF</td></tr> <tr><td>2229000300</td><td>SAF</td></tr> <tr><td>-</td><td>SCANIA</td></tr> <tr><td>25004</td><td>SEG-SAMRO</td></tr> <tr><td>11041011</td><td>TECMA</td></tr> <tr><td>21071483</td><td>TERBERG</td></tr> <tr><td>91687700000</td><td>TITAN</td></tr> <tr><td>65022347Y</td><td>TRAILOR</td></tr> <tr><td>65023482</td><td>TRAILOR</td></tr> <tr><td>36158</td><td>TRAILOR</td></tr> <tr><td>ST 225-675</td><td>TROUILLET</td></tr> <tr><td>644285</td><td>VIBERTI</td></tr> <tr><td>128147122</td><td>VIBERTI</td></tr> <tr><td>US 06364FS</td><td>WEWELER</td></tr> <tr><td>US 06364FS</td><td>WEWELER</td></tr> <tr><td>US 07345</td><td>WEWELER</td></tr> <tr><td>US 87408F</td><td>WEWELER</td></tr> <tr><td>785170</td><td>YORK</td></tr> </tbody> </table>	448543	ACERBI	42402003	BERTOJA	388491	DAF	143908-3	ERF	003615E	FRUEHAUF	15634	GRANNING	785170	HENDRICKSON	Y505801	HENDRICKSON	B 2063	HENDRICKSON	505859	HENDRICKSON	8121964	IVECO	4731033000	KAESSBOHRER	4731030000	KAESSBOHRER	22282	NEWAY	175005	PEGASO	250991	PIACENZA	21215633	ROR - MERITOR	5000790692	RVI	5010130925	RVI	8403/102	SAE	3229000300	SAF	3229001800	SAF	3228000300	SAF	2229000300	SAF	-	SCANIA	25004	SEG-SAMRO	11041011	TECMA	21071483	TERBERG	91687700000	TITAN	65022347Y	TRAILOR	65023482	TRAILOR	36158	TRAILOR	ST 225-675	TROUILLET	644285	VIBERTI	128147122	VIBERTI	US 06364FS	WEWELER	US 06364FS	WEWELER	US 07345	WEWELER	US 87408F	WEWELER	785170	YORK
448543	ACERBI																																																																																	
42402003	BERTOJA																																																																																	
388491	DAF																																																																																	
143908-3	ERF																																																																																	
003615E	FRUEHAUF																																																																																	
15634	GRANNING																																																																																	
785170	HENDRICKSON																																																																																	
Y505801	HENDRICKSON																																																																																	
B 2063	HENDRICKSON																																																																																	
505859	HENDRICKSON																																																																																	
8121964	IVECO																																																																																	
4731033000	KAESSBOHRER																																																																																	
4731030000	KAESSBOHRER																																																																																	
22282	NEWAY																																																																																	
175005	PEGASO																																																																																	
250991	PIACENZA																																																																																	
21215633	ROR - MERITOR																																																																																	
5000790692	RVI																																																																																	
5010130925	RVI																																																																																	
8403/102	SAE																																																																																	
3229000300	SAF																																																																																	
3229001800	SAF																																																																																	
3228000300	SAF																																																																																	
2229000300	SAF																																																																																	
-	SCANIA																																																																																	
25004	SEG-SAMRO																																																																																	
11041011	TECMA																																																																																	
21071483	TERBERG																																																																																	
91687700000	TITAN																																																																																	
65022347Y	TRAILOR																																																																																	
65023482	TRAILOR																																																																																	
36158	TRAILOR																																																																																	
ST 225-675	TROUILLET																																																																																	
644285	VIBERTI																																																																																	
128147122	VIBERTI																																																																																	
US 06364FS	WEWELER																																																																																	
US 06364FS	WEWELER																																																																																	
US 07345	WEWELER																																																																																	
US 87408F	WEWELER																																																																																	
785170	YORK																																																																																	

I nominativi dei costruttori e i relativi riferimenti originali citati nel presente catalogo sono riportati a puro titolo indicativo. I nostri prodotti non sono originali ma con essi intercambiabili.
 The name of manufacturers and the o.e. references mentioned in this catalogue are given for cross-reference purposes only. Our products are not original but interchangeable with.

TIPO - TYPE	CODICE - CODE	RIFERIMENTO ORIGINALE - O. E. REFERENCE
<p>D277</p>	<p>277.4.504</p>	<p>0.41.03.013.0 B.P.W.</p>
<p>D277</p>	<p>277.4.505</p>	<p>3229003100 SAF</p>
<p>D277</p>	<p>277.4.505/1</p>	<p>NEW</p> <p>3228002700 SAF</p>

I nominativi dei costruttori e i relativi riferimenti originali citati nel presente catalogo sono riportati a puro titolo indicativo. I nostri prodotti non sono originali ma con essi intercambiabili.
 The name of manufacturers and the o.e. references mentioned in this catalogue are given for cross-reference purposes only. Our products are not original but interchangeable with.



TIPO - TYPE	CODICE - CODE	RIFERIMENTO ORIGINALE - O. E. REFERENCE					
<p style="text-align: center;">D277</p>	<p style="text-align: center;">277.4.505/2</p>	<p style="text-align: center;">NEW</p> <table border="1" data-bbox="798 383 1525 412"> <tr> <td data-bbox="798 383 1002 412">3228003100</td> <td data-bbox="1002 383 1525 412">SAF</td> </tr> </table>		3228003100	SAF		
3228003100	SAF						
<p style="text-align: center;">D277</p>	<p style="text-align: center;">277.4.506</p>	<table border="1" data-bbox="798 947 1525 976"> <tr> <td data-bbox="798 947 1002 976">526823</td> <td data-bbox="1002 947 1525 976">DAF</td> </tr> <tr> <td data-bbox="798 976 1002 1005">5000745918</td> <td data-bbox="1002 976 1525 1005">RVI</td> </tr> </table>		526823	DAF	5000745918	RVI
526823	DAF						
5000745918	RVI						

I nominativi dei costruttori e i relativi riferimenti originali citati nel presente catalogo sono riportati a puro titolo indicativo. I nostri prodotti non sono originali ma con essi intercambiabili.
 The name of manufacturers and the o.e. references mentioned in this catalogue are given for cross-reference purposes only. Our products are not original but interchangeable with.



TIPO - TYPE	CODICE - CODE	RIFERIMENTO ORIGINALE - O. E. REFERENCE
-------------	---------------	---

D277

277.4.507

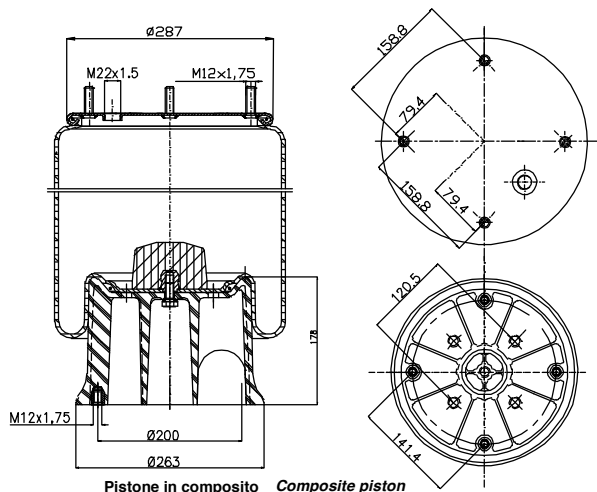

Pistone in composito Composite piston

448543	ACERBI
42402003	BERTOJA
388491	DAF
143908-3	ERF
003615E	FRUEHAUF
15634	GRANNING
785170	HENDRICKSON
Y505801	HENDRICKSON
505859	HENDRICKSON
B 2063	HENDRICKSON
Y505801	HENDRICKSON
8121964	IVECO
4731033000	KAESSBOHRER
4731030000	KAESSBOHRER
22282	NEWAY
175005	PEGASO
250991	PIACENZA
21215633	ROR - MERITOR
21222239	ROR - MERITOR
5000790692	RVI
5010130925	RVI
8403/102	SAE
3229000300	SAF
3228000300	SAF
3229001800	SAF
2229000300	SAF
-	SCANIA
25004	SEG-SAMRO
11041011	TECMA
21071483	TERBERG
91687700000	TITAN
65022347Y	TRAILOR
65023482	TRAILOR
36158	TRAILOR
ST 225-675	TROUILLET
644285	VIBERTI
128147122	VIBERTI
US 06364FS	WEWELER
US 06364FS	WEWELER
US 07345	WEWELER
US 87408F	WEWELER
785170	YORK

I nominativi dei costruttori e i relativi riferimenti originali citati nel presente catalogo sono riportati a puro titolo indicativo. I nostri prodotti non sono originali ma con essi intercambiabili.
The name of manufacturers and the o.e. references mentioned in this catalogue are given for cross-reference purposes only. Our products are not original but interchangeable with.



TIPO - TYPE	CODICE - CODE	RIFERIMENTO ORIGINALE - O. E. REFERENCE	
<p>D277</p> <p>Pistone in composito Composite piston</p>	<p>277.4.508</p>	2923VK	SAF
<p>D277/B</p>	<p>277.0.424</p>	-	-
<p>D277/B</p>	<p>277.2.420</p>	22.114.03	BATTAGLINO
		70100029	PEZZAIOLI
		05101009	S.T. SYSTEM TRUCK
		1006562	ZORZI

I nominativi dei costruttori e i relativi riferimenti originali citati nel presente catalogo sono riportati a puro titolo indicativo. I nostri prodotti non sono originali ma con essi intercambiabili.
 The name of manufacturers and the o.e. references mentioned in this catalogue are given for cross-reference purposes only. Our products are not original but interchangeable with.



TIPO - TYPE	CODICE - CODE	RIFERIMENTO ORIGINALE - O. E. REFERENCE	
<p>D277/B</p>	<p>277.2.421</p>	46311001	BERTOJA
		1006546	ZORZI
<p>D277/B</p>	<p>277.2.422</p>	NEW	
		US 073387 RP	WEWELER

I nominativi dei costruttori e i relativi riferimenti originali citati nel presente catalogo sono riportati a puro titolo indicativo. I nostri prodotti non sono originali ma con essi intercambiabili.
 The name of manufacturers and the o.e. references mentioned in this catalogue are given for cross-reference purposes only. Our products are not original but interchangeable with.



TIPO - TYPE	CODICE - CODE	RIFERIMENTO ORIGINALE - O. E. REFERENCE	
<p>D277/B</p>	<p>277.4.420</p>	<p>99381036 91619007 45402002 15635 506243 785168 B 2065 Y506201 9988467 211586 811905 17204517 21208082 21215632 5000452939 9212050 2229000200 222800200 - 25008 2509999 2500008 11041027 6504646G HB 10315 1080707 US 00622 US 06286FS US 06345 US 07337F US 874131F US 87413P 506243/01 785168</p>	<p>AUSTERAS BARTOLETTI BERTOJA GRANNING HENDRICKSON HENDRICKSON HENDRICKSON HENDRICKSON IVECO NEWAY ROLFO ROR - MERITOR ROR - MERITOR ROR - MERITOR RVI SAE SAF SAF SCANIA SEG-SAMRO SEG-SAMRO SEG-SAMRO TECMA TRAILOR TROUILLET VOLVO WEWELER WEWELER WEWELER WEWELER WEWELER WEWELER YORK YORK</p>
<p>D277/B</p>	<p>277.4.422</p>	<p>05101014</p>	<p>NEW S.T. SYSTEM TRUCK</p>

I nominativi dei costruttori e i relativi riferimenti originali citati nel presente catalogo sono riportati a puro titolo indicativo. I nostri prodotti non sono originali ma con essi intercambiabili.
The name of manufacturers and the o.e. references mentioned in this catalogue are given for cross-reference purposes only. Our products are not original but interchangeable with.

TIPO - TYPE	CODICE - CODE	RIFERIMENTO ORIGINALE - O. E. REFERENCE				
<p>D277/B</p>	<p>277.4.423</p>	<table border="1"> <tr> <td>3229002700</td> <td>SAF</td> </tr> </table>	3229002700	SAF		
3229002700	SAF					
<p>D277/B</p>	<p>277.4.424</p>	<table border="1"> <tr> <td>3229003600</td> <td>SAF</td> </tr> <tr> <td>US 07074F</td> <td>WEWELER</td> </tr> </table>	3229003600	SAF	US 07074F	WEWELER
3229003600	SAF					
US 07074F	WEWELER					
<p>D277/B</p>	<p>277.4.424/1</p>	<p>NEW</p> <table border="1"> <tr> <td>3228102700</td> <td>SAF</td> </tr> </table>	3228102700	SAF		
3228102700	SAF					

I nominativi dei costruttori e i relativi riferimenti originali citati nel presente catalogo sono riportati a puro titolo indicativo. I nostri prodotti non sono originali ma con essi intercambiabili.
 The name of manufacturers and the o.e. references mentioned in this catalogue are given for cross-reference purposes only. Our products are not original but interchangeable with.



TIPO - TYPE	CODICE - CODE	RIFERIMENTO ORIGINALE - O. E. REFERENCE							
<p>D277/B</p>	<p>277.4.425/1</p>	<table border="1"> <tr> <td data-bbox="798 383 1002 409">99381050.1</td> <td data-bbox="1002 383 1525 409">AUSTERAS</td> </tr> </table>		99381050.1	AUSTERAS				
99381050.1	AUSTERAS								
<p>D277/C</p>	<p>277.4.501</p>	<table border="1"> <tr> <td data-bbox="798 947 1002 974">0.41.04.005.0</td> <td data-bbox="1002 947 1525 974">B.P.W.</td> </tr> </table>		0.41.04.005.0	B.P.W.				
0.41.04.005.0	B.P.W.								
<p>D277/D</p>	<p>277.2.520</p>	<table border="1"> <tr> <td data-bbox="798 1507 1002 1534">A946 328 1501</td> <td data-bbox="1002 1507 1525 1534">MERCEDS / DISCOS</td> </tr> <tr> <td data-bbox="798 1534 1002 1561">S015323</td> <td data-bbox="1002 1534 1525 1561">SCHMITZ</td> </tr> <tr> <td data-bbox="798 1561 1002 1588">US 04030P</td> <td data-bbox="1002 1561 1525 1588">WEWELER</td> </tr> </table>		A946 328 1501	MERCEDS / DISCOS	S015323	SCHMITZ	US 04030P	WEWELER
A946 328 1501	MERCEDS / DISCOS								
S015323	SCHMITZ								
US 04030P	WEWELER								

I nominativi dei costruttori e i relativi riferimenti originali citati nel presente catalogo sono riportati a puro titolo indicativo. I nostri prodotti non sono originali ma con essi intercambiabili.
 The name of manufacturers and the o.e. references mentioned in this catalogue are given for cross-reference purposes only. Our products are not original but interchangeable with.

TIPO - TYPE	CODICE - CODE	RIFERIMENTO ORIGINALE - O. E. REFERENCE	
<p>D277/D</p>	<p>277.4.520</p>	0.41.03.003.0	B.P.W.
		05.020.0100	CAMPANA
<p>D277/D</p>	<p>277.4.524</p>	0.41.03.019.0	B.P.W.
<p>D277/DA</p>	<p>277.4.521</p>	0.41.03.009.0	B.P.W.

I nominativi dei costruttori e i relativi riferimenti originali citati nel presente catalogo sono riportati a puro titolo indicativo. I nostri prodotti non sono originali ma con essi intercambiabili.
 The name of manufacturers and the o.e. references mentioned in this catalogue are given for cross-reference purposes only. Our products are not original but interchangeable with.



TIPO - TYPE	CODICE - CODE	RIFERIMENTO ORIGINALE - O. E. REFERENCE	
<p>D277/DA</p>	<p>277.4.523</p>	0.41.03.016.0	B.P.W.
<p>D278/D</p>	<p>278.4.535</p>	NEW	
<p>D278/E</p>	<p>278.2.430</p>	0.41.04.001.0	B.P.W.
		05.040.0100	CAMPANA

I nominativi dei costruttori e i relativi riferimenti originali citati nel presente catalogo sono riportati a puro titolo indicativo. I nostri prodotti non sono originali ma con essi intercambiabili.
 The name of manufacturers and the o.e. references mentioned in this catalogue are given for cross-reference purposes only. Our products are not original but interchangeable with.

TIPO - TYPE	CODICE - CODE	RIFERIMENTO ORIGINALE - O. E. REFERENCE	
<p>D278/E</p>	<p>278.2.432</p>	<p>03003000080 TRAS CAR</p>	
<p>D278/E</p>	<p>278.2.433</p>	<p>SPMHB016 SANSAVINI</p>	
<p>D278/E</p>	<p>278.2.437</p>	<p>70100010 PEZZAIOLI</p>	

I nominativi dei costruttori e i relativi riferimenti originali citati nel presente catalogo sono riportati a puro titolo indicativo. I nostri prodotti non sono originali ma con essi intercambiabili.
 The name of manufacturers and the o.e. references mentioned in this catalogue are given for cross-reference purposes only. Our products are not original but interchangeable with.



TIPO - TYPE	CODICE - CODE	RIFERIMENTO ORIGINALE - O. E. REFERENCE	
<p>D278/E</p>	<p>278.2.439</p>	20.38.0002.0	GIRELLI
<p>D278/EB</p>	<p>278.2.340</p>	CCA00200	B.B.M. BOLPAGNI
<p>D278/EB</p>	<p>278.2.341</p>	-	NOMECC

I nominativi dei costruttori e i relativi riferimenti originali citati nel presente catalogo sono riportati a puro titolo indicativo. I nostri prodotti non sono originali ma con essi intercambiabili.
 The name of manufacturers and the o.e. references mentioned in this catalogue are given for cross-reference purposes only. Our products are not original but interchangeable with.

TIPO - TYPE	CODICE - CODE	RIFERIMENTO ORIGINALE - O. E. REFERENCE	
<p>D278/EB</p>	<p>278.2.342</p>	<p>21225695 ROR - MERITOR</p>	
<p>D278/EC</p>	<p>278.2.401</p>	<p>70100045 PEZZAIOLI</p>	
<p>D278/F</p>	<p>278.2.520</p>	<p>99381031 AUSTERAS</p>	

I nominativi dei costruttori e i relativi riferimenti originali citati nel presente catalogo sono riportati a puro titolo indicativo. I nostri prodotti non sono originali ma con essi intercambiabili.
 The name of manufacturers and the o.e. references mentioned in this catalogue are given for cross-reference purposes only. Our products are not original but interchangeable with.



TIPO - TYPE	CODICE - CODE	RIFERIMENTO ORIGINALE - O. E. REFERENCE	
<p>D278/F</p>	<p>278.2.522</p>	-	-
<p>D278/FB</p>	<p>278.2.491</p>	70100044	PEZZAIOLI
<p>D278/FB</p>	<p>278.2.492</p>	05101012	NEW S.T. SYSTEM TRUCK

I nominativi dei costruttori e i relativi riferimenti originali citati nel presente catalogo sono riportati a puro titolo indicativo. I nostri prodotti non sono originali ma con essi intercambiabili.
 The name of manufacturers and the o.e. references mentioned in this catalogue are given for cross-reference purposes only. Our products are not original but interchangeable with.

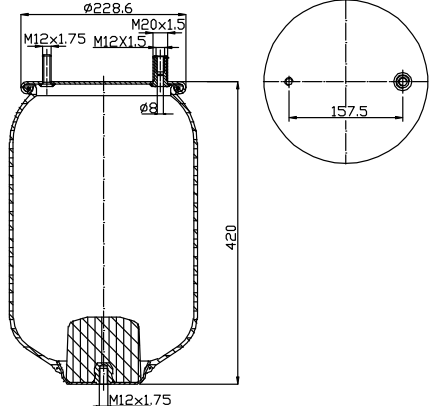
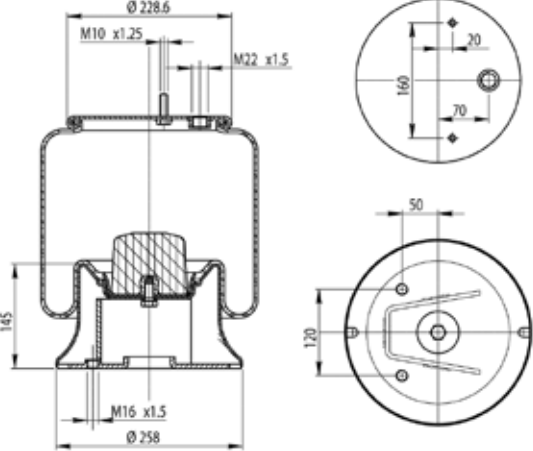
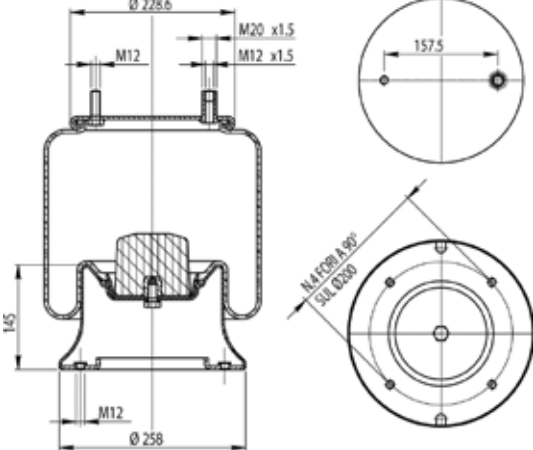

TIPO - TYPE	CODICE - CODE	RIFERIMENTO ORIGINALE - O. E. REFERENCE	
<p>D278/G</p> 	<p>278.0.421</p>		
		90557077	NEWAY
		90557027	NEWAY
<p>D278/G</p> 	<p>278.2.422</p>		
		4823115	BARTOLETTI
		BT0319	BELLE TRAILERS
		45402004	BERTOJA
		012220530	GIRELLI
		1528	GRANNING
		1359	GRANNING
		B 2066	HENDRICKSON
		90557075	NEWAY
		90557027	NEWAY
		21216135	ROR - MERITOR
		21208939	ROR - MERITOR
		05101002	S.T. SYSTEM TRUCK
		520 728	TRANSPART
		US 35864	WEWELER
		1006550	ZORZI
<p>D278/G</p> 	<p>278.4.421</p>		
		HA 10001	HENDRICKSON
		21215762	ROR - MERITOR
		21215761	ROR - MERITOR
		US 97306	WEWELER
		US 35864F	WEWELER

I nominativi dei costruttori e i relativi riferimenti originali citati nel presente catalogo sono riportati a puro titolo indicativo. I nostri prodotti non sono originali ma con essi intercambiabili.
 The name of manufacturers and the o.e. references mentioned in this catalogue are given for cross-reference purposes only. Our products are not original but interchangeable with.



TIPO - TYPE	CODICE - CODE	RIFERIMENTO ORIGINALE - O. E. REFERENCE
<p>D278/G</p>	<p>278.4.421/1</p>	<p>NEW</p> <p>21226046 ROR - MERITOR</p>
<p>D278/G</p>	<p>278.4.422</p>	<p>99381022 AUSTERAS</p>
<p>D278/H</p>	<p>278.0.511</p>	<ul style="list-style-type: none"> - CARDI - FRUEHAUF-ACERBI-TRAILOR - VIBERTI

I nominativi dei costruttori e i relativi riferimenti originali citati nel presente catalogo sono riportati a puro titolo indicativo. I nostri prodotti non sono originali ma con essi intercambiabili.
 The name of manufacturers and the o.e. references mentioned in this catalogue are given for cross-reference purposes only. Our products are not original but interchangeable with.



TIPO - TYPE	CODICE - CODE	RIFERIMENTO ORIGINALE - O. E. REFERENCE																				
<p>D278/H</p> <p>Ø 228,6 M12 M20 x1,5 M12 x1,5 193 Ø 260 PISTONE IN COMPOSITO COMPOSITE PISTON</p>	<p>278.1.510</p>	<table border="1"> <tr><td>58051210</td><td>CARDI</td></tr> <tr><td>UJY 0099</td><td>FRUEHAUF</td></tr> <tr><td>UJB 0358</td><td>FRUEHAUF</td></tr> <tr><td>1525199</td><td>FRUEHAUF</td></tr> <tr><td>M001774</td><td>FRUEHAUF-ACERBI-TRAILOR</td></tr> <tr><td>700734</td><td>ROLFO</td></tr> <tr><td>H2500324</td><td>SEG-SAMRO</td></tr> <tr><td>HT 18002</td><td>TROUILLET</td></tr> <tr><td>128147123</td><td>VIBERTI</td></tr> <tr><td>1006564</td><td>ZORZI</td></tr> </table>	58051210	CARDI	UJY 0099	FRUEHAUF	UJB 0358	FRUEHAUF	1525199	FRUEHAUF	M001774	FRUEHAUF-ACERBI-TRAILOR	700734	ROLFO	H2500324	SEG-SAMRO	HT 18002	TROUILLET	128147123	VIBERTI	1006564	ZORZI
58051210	CARDI																					
UJY 0099	FRUEHAUF																					
UJB 0358	FRUEHAUF																					
1525199	FRUEHAUF																					
M001774	FRUEHAUF-ACERBI-TRAILOR																					
700734	ROLFO																					
H2500324	SEG-SAMRO																					
HT 18002	TROUILLET																					
128147123	VIBERTI																					
1006564	ZORZI																					
<p>D278/H</p> <p>Ø 228,6 M12 M20x1,5 M12x1,5 193 Ø 260 PISTONE IN COMPOSITO COMPOSITE PISTON</p>	<p>278.1.511</p>	<table border="1"> <tr><td>58051200</td><td>CARDI</td></tr> <tr><td>128147121</td><td>VIBERTI</td></tr> </table>	58051200	CARDI	128147121	VIBERTI																
58051200	CARDI																					
128147121	VIBERTI																					
<p>D278/H</p> <p>Ø 228,6 M12 M20 x1,5 M12 x1,5 186 Ø 258 70,7 141 PISTONE IN COMPOSITO COMPOSITE PISTON</p>	<p>278.2.511</p>	<table border="1"> <tr><td>UJB 0203-001</td><td>ACERBI</td></tr> <tr><td>UJB 0203-001</td><td>FRUEHAUF</td></tr> </table>	UJB 0203-001	ACERBI	UJB 0203-001	FRUEHAUF																
UJB 0203-001	ACERBI																					
UJB 0203-001	FRUEHAUF																					

I nominativi dei costruttori e i relativi riferimenti originali citati nel presente catalogo sono riportati a puro titolo indicativo. I nostri prodotti non sono originali ma con essi intercambiabili.
The name of manufacturers and the o.e. references mentioned in this catalogue are given for cross-reference purposes only. Our products are not original but interchangeable with.



TIPO - TYPE	CODICE - CODE	RIFERIMENTO ORIGINALE - O. E. REFERENCE	
<p>D278/H</p>	<p>278.2.512</p>	<p>45402007</p>	<p>BERTOJA</p>
		<p>58050900</p>	<p>CARDI</p>
		<p>11808</p>	<p>OMAR</p>
		<p>112322</p>	<p>ROLFO</p>
		<p>1006551</p>	<p>ZORZI</p>
<p>D278/H</p>	<p>278.2.515</p>	<p>-</p>	
		<p>FRUEHAHF MONTENEGRO</p>	
<p>D278/H</p>	<p>278.4.511</p>	<p>21215891</p>	<p>ROR - MERITOR</p>
		<p>US 93800</p>	<p>WEWELER</p>

I nominativi dei costruttori e i relativi riferimenti originali citati nel presente catalogo sono riportati a puro titolo indicativo. I nostri prodotti non sono originali ma con essi intercambiabili.
 The name of manufacturers and the o.e. references mentioned in this catalogue are given for cross-reference purposes only. Our products are not original but interchangeable with.

TIPO - TYPE	CODICE - CODE	RIFERIMENTO ORIGINALE - O. E. REFERENCE							
<p>D278/H</p>	<p>278.4.511/1</p>	<p>NEW</p> <table border="1" data-bbox="721 383 1444 412"> <tr> <td>21226039</td> <td>ROR - MERITOR</td> </tr> </table>		21226039	ROR - MERITOR				
21226039	ROR - MERITOR								
<p>D278/H</p>	<p>278.4.512</p>	<table border="1" data-bbox="721 943 1444 1028"> <tr> <td>0.41.03.007.0</td> <td>B.P.W.</td> </tr> <tr> <td>05.050.0100</td> <td>CAMPANA</td> </tr> <tr> <td>28100002</td> <td>CAMPANA</td> </tr> </table>		0.41.03.007.0	B.P.W.	05.050.0100	CAMPANA	28100002	CAMPANA
0.41.03.007.0	B.P.W.								
05.050.0100	CAMPANA								
28100002	CAMPANA								
<p>D278/H</p>	<p>278.4.514</p>	<table border="1" data-bbox="721 1507 1444 1561"> <tr> <td>128147109</td> <td>VIBERTI</td> </tr> <tr> <td>1006559</td> <td>ZORZI</td> </tr> </table>		128147109	VIBERTI	1006559	ZORZI		
128147109	VIBERTI								
1006559	ZORZI								

I nominativi dei costruttori e i relativi riferimenti originali citati nel presente catalogo sono riportati a puro titolo indicativo. I nostri prodotti non sono originali ma con essi intercambiabili.
 The name of manufacturers and the o.e. references mentioned in this catalogue are given for cross-reference purposes only. Our products are not original but interchangeable with.



TIPO - TYPE	CODICE - CODE	RIFERIMENTO ORIGINALE - O. E. REFERENCE	
<p>D278/H</p>	<p>278.4.516</p>	128147111	VIBERTI
<p>D278/H1</p>	<p>278.4.517</p>	NEW	
<p>D278/HS</p>	<p>278.0.531</p>	751065	SCHMITZ

I nominativi dei costruttori e i relativi riferimenti originali citati nel presente catalogo sono riportati a puro titolo indicativo. I nostri prodotti non sono originali ma con essi intercambiabili.
 The name of manufacturers and the o.e. references mentioned in this catalogue are given for cross-reference purposes only. Our products are not original but interchangeable with.



TIPO - TYPE	CODICE - CODE	RIFERIMENTO ORIGINALE - O. E. REFERENCE	
<p>D278/HS</p> <p>Pistone in composito Composite piston</p>	<p>278.1.530</p>		
		750999	SCHMITZ
		US 06285F	WEWELER
<p>D278/HS</p> <p>Pistone in composito Composite piston</p>	<p>278.1.530/1</p>	NEW	
		750999	SCHMITZ
		US 06285F	WEWELER
<p>D278/M</p>	<p>278.2.500</p>	1386200	SCANIA serie 4 Nor. (Anteriore / Rear)
		1370744	SCANIA serie 4 Nor. (Anteriore / Rear)
		1362147	SCANIA serie 4 Nor. (Anteriore / Rear)

I nominativi dei costruttori e i relativi riferimenti originali citati nel presente catalogo sono riportati a puro titolo indicativo. I nostri prodotti non sono originali ma con essi intercambiabili.
 The name of manufacturers and the o.e. references mentioned in this catalogue are given for cross-reference purposes only. Our products are not original but interchangeable with.



TIPO - TYPE	CODICE - CODE	RIFERIMENTO ORIGINALE - O. E. REFERENCE	
<p>D278/MA</p>	<p>278.2.415</p>	1386199	SCANIA serie 4 rib
		1370743	SCANIA serie 4 rib
		1362145	SCANIA serie 4 rib.
<p>D278/N</p>	<p>278.2.330</p>	488266	SCANIA BUS serie 4 Anteriore / Front
		470921	SCANIA BUS serie 4 Anteriore / Front
		1515499	SCANIA BUS serie 4 Anteriore / Front
		1440302	SCANIA BUS serie 4 Anteriore / Front
<p>D278/N</p>	<p>278.2.330/1</p>	NEW	
		1726238	SCANIA

I nominativi dei costruttori e i relativi riferimenti originali citati nel presente catalogo sono riportati a puro titolo indicativo. I nostri prodotti non sono originali ma con essi intercambiabili.
 The name of manufacturers and the o.e. references mentioned in this catalogue are given for cross-reference purposes only. Our products are not original but interchangeable with.

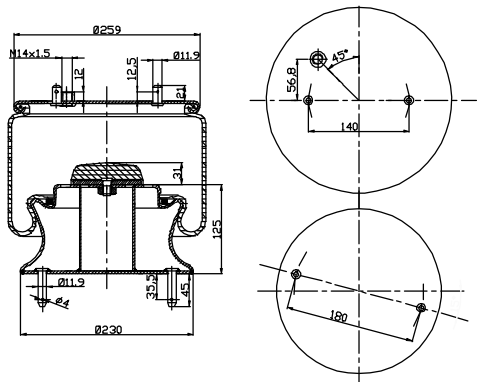
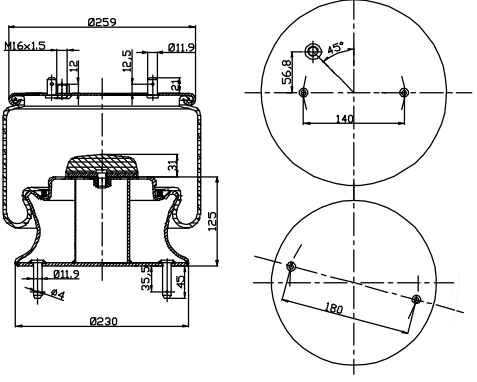
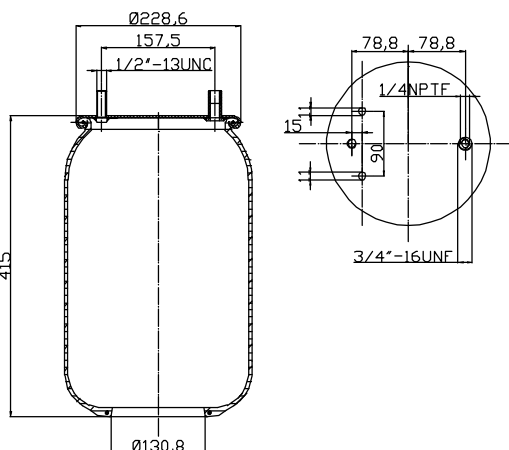

TIPO - TYPE	CODICE - CODE	RIFERIMENTO ORIGINALE - O. E. REFERENCE	
<p>D278/NA</p> 	<p>278.2.300</p>	<p>1440301</p>	<p>SCANIA BUS serie 4 Anteriore / Front</p>
		<p>470920</p>	<p>SCANIA BUS serie 4 Anteriore / Front</p>
<p>D278/NA</p> 	<p>278.2.300/1</p>	<p>NEW</p>	
		<p>1726237</p>	<p>SCANIA</p>
<p>D278/R</p> 	<p>278.0.434</p>	<p>6813200017</p>	<p>FREIGHTLINER</p>
		<p>1613810000</p>	<p>FREIGHTLINER</p>

I nominativi dei costruttori e i relativi riferimenti originali citati nel presente catalogo sono riportati a puro titolo indicativo. I nostri prodotti non sono originali ma con essi intercambiabili.
 The name of manufacturers and the o.e. references mentioned in this catalogue are given for cross-reference purposes only. Our products are not original but interchangeable with.



TIPO - TYPE	CODICE - CODE	RIFERIMENTO ORIGINALE - O. E. REFERENCE	
<p>D278/R</p>	<p>278.1.430</p>	6813200017	FREIGHTLINER
		1613810000	FREIGHTLINER
<p>D278/S</p>	<p>278.0.451</p>	-	SAF
<p>D278/S</p>	<p>278.0.452</p>	-	SAF

I nominativi dei costruttori e i relativi riferimenti originali citati nel presente catalogo sono riportati a puro titolo indicativo. I nostri prodotti non sono originali ma con essi intercambiabili.
 The name of manufacturers and the o.e. references mentioned in this catalogue are given for cross-reference purposes only. Our products are not original but interchangeable with.

TIPO - TYPE	CODICE - CODE	RIFERIMENTO ORIGINALE - O. E. REFERENCE
<p>D278/S</p> <p>Pistone in composito <i>Composite piston</i></p>	<p>278.1.452</p>	<p>NEW</p> <p>3229003900 SAF</p>
<p>D278/S</p> <p>Pistone in composito <i>Composite piston</i></p>	<p>278.1.453</p>	<p>NEW</p> <p>3229003800 SAF</p>
<p>D278/S</p> <p>Pistone in composito <i>Composite piston</i></p>	<p>278.1.454</p>	<p>NEW</p> <p>3229104300 SAF - MENCİ</p>

I nominativi dei costruttori e i relativi riferimenti originali citati nel presente catalogo sono riportati a puro titolo indicativo. I nostri prodotti non sono originali ma con essi intercambiabili.
 The name of manufacturers and the o.e. references mentioned in this catalogue are given for cross-reference purposes only. Our products are not original but interchangeable with.



TIPO - TYPE	CODICE - CODE	RIFERIMENTO ORIGINALE - O. E. REFERENCE	
<p>D278/S</p> <p>Pistone in composito Composite piston</p>	<p>278.1.455</p>		
		3229003300	SAF
<p>D278/S</p>	<p>278.4.451</p>		
		2229000700	SAF
<p>D278/S</p> <p>PISTONE IN COMPOSITO COMPOSITE PISTON</p>	<p>278.4.452</p>	4284300301	SAF
		3229000702	SAF
		3229000701	SAF
		3229000700	SAF
		2229000700	SAF

I nominativi dei costruttori e i relativi riferimenti originali citati nel presente catalogo sono riportati a puro titolo indicativo. I nostri prodotti non sono originali ma con essi intercambiabili.
The name of manufacturers and the o.e. references mentioned in this catalogue are given for cross-reference purposes only. Our products are not original but interchangeable with.

TIPO - TYPE	CODICE - CODE	RIFERIMENTO ORIGINALE - O. E. REFERENCE	
<p>D278/S</p>	<p>278.4.453</p>		
		3229002900	SAF
		3229000702	SAF
<p>D278/S</p> <p>PISTONE IN COMPOSITO COMPOSITE PISTON</p>	<p>278.4.454</p>		
		3229002900	SAF
<p>D278/S</p> <p>Pistone in composito Composite piston</p>	<p>278.4.454/1</p>		
		-	-

I nominativi dei costruttori e i relativi riferimenti originali citati nel presente catalogo sono riportati a puro titolo indicativo. I nostri prodotti non sono originali ma con essi intercambiabili.
The name of manufacturers and the o.e. references mentioned in this catalogue are given for cross-reference purposes only. Our products are not original but interchangeable with.

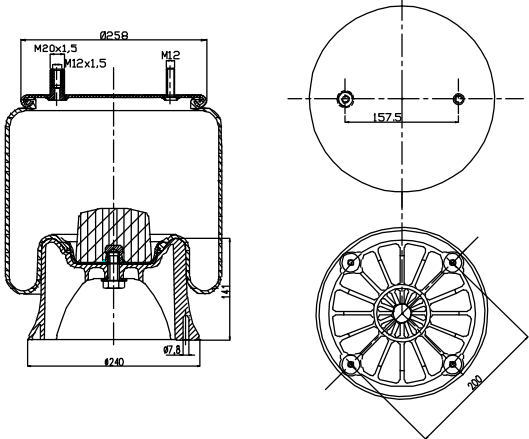
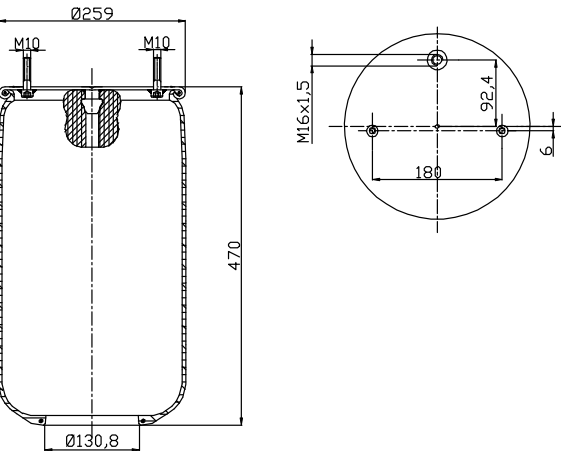
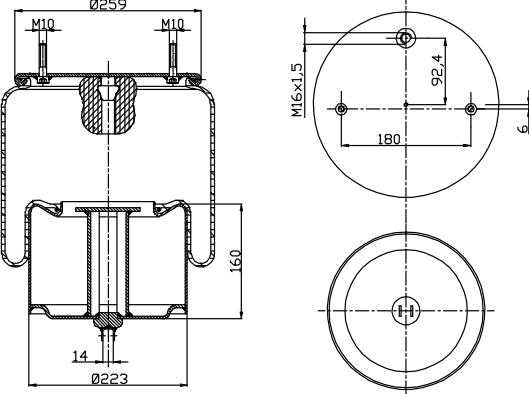

TIPO - TYPE	CODICE - CODE	RIFERIMENTO ORIGINALE - O. E. REFERENCE	
<p>D278/S</p>  <p>Pistone in composito <i>Composite piston</i></p>	<p>278.4.456</p>	<p>NEW</p> <p>3229004000 SAF - MENCI</p>	
<p>D278/V</p> 	<p>278.0.471</p>	<p>1079718 VOLVO FM12 - FH12</p>	
<p>D278/V</p> 	<p>278.1.470</p>	<p>20554759 VOLVO FM12 - FH12</p> <p>1075363 VOLVO FM12 - FH12</p>	

I nominativi dei costruttori e i relativi riferimenti originali citati nel presente catalogo sono riportati a puro titolo indicativo. I nostri prodotti non sono originali ma con essi intercambiabili.
 The name of manufacturers and the o.e. references mentioned in this catalogue are given for cross-reference purposes only. Our products are not original but interchangeable with.

TIPO - TYPE	CODICE - CODE	RIFERIMENTO ORIGINALE - O. E. REFERENCE	
<p>D278/V1</p>	<p>278.1.355</p>	<p>1076076 VOLVO</p>	
<p>C282</p>	<p>282.2.530</p>	<p>22.114.09 BATTAGLINO</p>	
<p>C282</p>	<p>282.2.533</p>	<p>98381037 AUSTERAS</p>	

I nominativi dei costruttori e i relativi riferimenti originali citati nel presente catalogo sono riportati a puro titolo indicativo. I nostri prodotti non sono originali ma con essi intercambiabili.
 The name of manufacturers and the o.e. references mentioned in this catalogue are given for cross-reference purposes only. Our products are not original but interchangeable with.



TIPO - TYPE	CODICE - CODE	RIFERIMENTO ORIGINALE - O. E. REFERENCE
<p>C282</p>	<p>282.2.535</p>	<p>70102000 PEZZAIOLI</p>
<p>C282</p>	<p>282.2.537</p>	<p>99381047 AUSTERAS</p>
<p>C282</p>	<p>282.4.532</p>	<p>- F.A.S.T. ENGENIRY</p>

I nominativi dei costruttori e i relativi riferimenti originali citati nel presente catalogo sono riportati a puro titolo indicativo. I nostri prodotti non sono originali ma con essi intercambiabili.
 The name of manufacturers and the o.e. references mentioned in this catalogue are given for cross-reference purposes only. Our products are not original but interchangeable with.



TIPO - TYPE	CODICE - CODE	RIFERIMENTO ORIGINALE - O. E. REFERENCE
<p>C282/B</p>	<p>282.2.432</p>	<p>- PEZZAIOLI</p>
<p>C282/C</p>	<p>282.0.460</p>	<p>A9423202321 MERCEDES ACTROS MP2</p>
<p>C282/C</p>	<p>282.0.461</p>	<p>A9423202221 MERCEDES ACTROS MP2</p>

I nominativi dei costruttori e i relativi riferimenti originali citati nel presente catalogo sono riportati a puro titolo indicativo. I nostri prodotti non sono originali ma con essi intercambiabili.
 The name of manufacturers and the o.e. references mentioned in this catalogue are given for cross-reference purposes only. Our products are not original but interchangeable with.

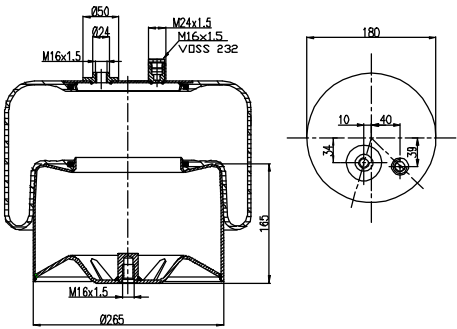
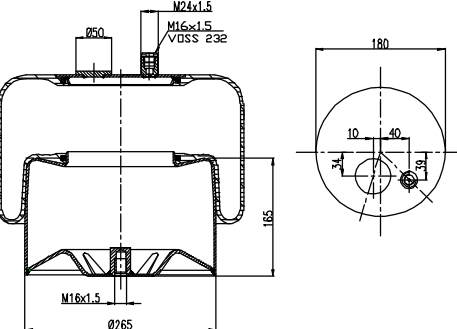
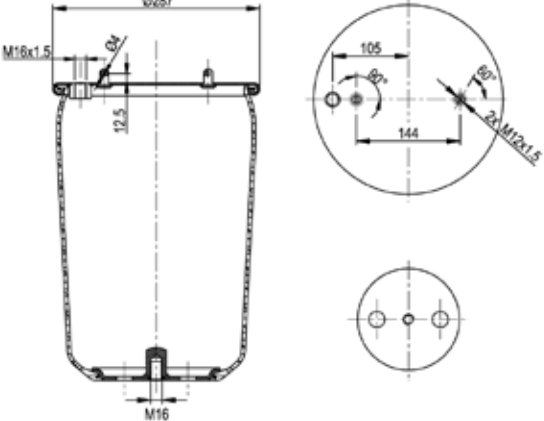

TIPO - TYPE	CODICE - CODE	RIFERIMENTO ORIGINALE - O. E. REFERENCE							
<p>C282/C</p> 	<p>282.1.460</p>	<table border="1"> <tr> <td data-bbox="798 383 1002 409">A9423202321</td> <td data-bbox="1002 383 1527 409">MERCEDES ACTROS MP2</td> </tr> </table>		A9423202321	MERCEDES ACTROS MP2				
A9423202321	MERCEDES ACTROS MP2								
<p>C282/C</p> 	<p>282.1.461</p>	<table border="1"> <tr> <td data-bbox="798 949 1002 976">A9423202221</td> <td data-bbox="1002 949 1527 976">MERCEDES ACTROS MP2</td> </tr> </table>		A9423202221	MERCEDES ACTROS MP2				
A9423202221	MERCEDES ACTROS MP2								
<p>C282/H</p> 	<p>282.0.601</p>	<p>REPLACED BY 287.0.603</p> <table border="1"> <tr> <td data-bbox="798 1507 1002 1534">1440294</td> <td data-bbox="1002 1507 1527 1534">SCANIA</td> </tr> <tr> <td data-bbox="798 1534 1002 1561">1379393</td> <td data-bbox="1002 1534 1527 1561">SCANIA</td> </tr> <tr> <td data-bbox="798 1561 1002 1588">1379392</td> <td data-bbox="1002 1561 1527 1588">SCANIA</td> </tr> </table>		1440294	SCANIA	1379393	SCANIA	1379392	SCANIA
1440294	SCANIA								
1379393	SCANIA								
1379392	SCANIA								

I nominativi dei costruttori e i relativi riferimenti originali citati nel presente catalogo sono riportati a puro titolo indicativo. I nostri prodotti non sono originali ma con essi intercambiabili.
 The name of manufacturers and the o.e. references mentioned in this catalogue are given for cross-reference purposes only. Our products are not original but interchangeable with.



TIPO - TYPE	CODICE - CODE	RIFERIMENTO ORIGINALE - O. E. REFERENCE						
<p>C282/H</p>	<p>282.1.600</p>	<p>REPLACED BY 287.1.606</p> <table border="1"> <tr> <td>1440294</td> <td>SCANIA</td> </tr> <tr> <td>1379393</td> <td>SCANIA</td> </tr> <tr> <td>1379392</td> <td>SCANIA</td> </tr> </table>	1440294	SCANIA	1379393	SCANIA	1379392	SCANIA
1440294	SCANIA							
1379393	SCANIA							
1379392	SCANIA							
<p>D286</p>	<p>286.2.420</p>	<table border="1"> <tr> <td>500330231</td> <td>IVECO BUS 491 Cityclass (da 2/98) (Anteriore / Front)</td> </tr> </table>	500330231	IVECO BUS 491 Cityclass (da 2/98) (Anteriore / Front)				
500330231	IVECO BUS 491 Cityclass (da 2/98) (Anteriore / Front)							
<p>D286</p>	<p>286.2.421</p>	<table border="1"> <tr> <td>500330232</td> <td>IVECO BUS 491 Cityclass (da 2/98) (Anteriore / Front)</td> </tr> </table>	500330232	IVECO BUS 491 Cityclass (da 2/98) (Anteriore / Front)				
500330232	IVECO BUS 491 Cityclass (da 2/98) (Anteriore / Front)							

I nominativi dei costruttori e i relativi riferimenti originali citati nel presente catalogo sono riportati a puro titolo indicativo. I nostri prodotti non sono originali ma con essi intercambiabili.
 The name of manufacturers and the o.e. references mentioned in this catalogue are given for cross-reference purposes only. Our products are not original but interchangeable with.



TIPO - TYPE	CODICE - CODE	RIFERIMENTO ORIGINALE - O. E. REFERENCE
<p style="text-align: center;">D286</p>	<p style="text-align: center;">286.2.422</p>	<p style="text-align: center;">NEW</p> <p>500324515 IVECO BUS 491 Cityclass</p>
<p style="text-align: center;">D286</p>	<p style="text-align: center;">286.2.423</p>	<p style="text-align: center;">NEW</p> <p>500324514 IVECO BUS 491 Cityclass</p>
<p style="text-align: center;">D287</p>	<p style="text-align: center;">287.0.521</p>	<p style="text-align: center;">- -</p>

I nominativi dei costruttori e i relativi riferimenti originali citati nel presente catalogo sono riportati a puro titolo indicativo. I nostri prodotti non sono originali ma con essi intercambiabili.
 The name of manufacturers and the o.e. references mentioned in this catalogue are given for cross-reference purposes only. Our products are not original but interchangeable with.



TIPO - TYPE	CODICE - CODE	RIFERIMENTO ORIGINALE - O. E. REFERENCE																	
<p style="text-align: center;">D287</p>	<p style="text-align: center;">287.4.520</p>	<table border="1"> <tr><td>3229001301</td><td>SAF</td></tr> <tr><td>1314906</td><td>SCANIA</td></tr> <tr><td>1107674</td><td>SCANIA</td></tr> <tr><td>1107647</td><td>SCANIA</td></tr> <tr><td>325748</td><td>SCANIA</td></tr> <tr><td>298568</td><td>SCANIA</td></tr> <tr><td>255295</td><td>SCANIA</td></tr> <tr><td>255293</td><td>SCANIA</td></tr> </table>	3229001301	SAF	1314906	SCANIA	1107674	SCANIA	1107647	SCANIA	325748	SCANIA	298568	SCANIA	255295	SCANIA	255293	SCANIA	
3229001301	SAF																		
1314906	SCANIA																		
1107674	SCANIA																		
1107647	SCANIA																		
325748	SCANIA																		
298568	SCANIA																		
255295	SCANIA																		
255293	SCANIA																		
<p style="text-align: center;">D287</p>	<p style="text-align: center;">287.4.521</p>	<table border="1"> <tr><td>-</td><td>AUSTERAS</td></tr> <tr><td>22.114.00</td><td>BATTAGLINO</td></tr> <tr><td>21222239</td><td>ROR - MERITOR</td></tr> </table>	-	AUSTERAS	22.114.00	BATTAGLINO	21222239	ROR - MERITOR											
-	AUSTERAS																		
22.114.00	BATTAGLINO																		
21222239	ROR - MERITOR																		
<p style="text-align: center;">D287</p>	<p style="text-align: center;">287.4.522</p>	<table border="1"> <tr><td>05.020.0105</td><td>CAMPANA</td></tr> <tr><td>28100006</td><td>CAMPANA</td></tr> </table>	05.020.0105	CAMPANA	28100006	CAMPANA													
05.020.0105	CAMPANA																		
28100006	CAMPANA																		

I nominativi dei costruttori e i relativi riferimenti originali citati nel presente catalogo sono riportati a puro titolo indicativo. I nostri prodotti non sono originali ma con essi intercambiabili.
 The name of manufacturers and the o.e. references mentioned in this catalogue are given for cross-reference purposes only. Our products are not original but interchangeable with.



TIPO - TYPE	CODICE - CODE	RIFERIMENTO ORIGINALE - O. E. REFERENCE	
<p>D287/A</p>	<p>287.2.510</p>	<p>91619005 58051000 112064 128147117 1006554</p>	<p>BARTOLETTI CARDI ROLFO VIBERTI ZORZI</p>
<p>D287/A</p>	<p>287.4.510</p>	<p>931410 21215633 2229000900 99100520019 11041015 US 93918</p>	<p>PEGASO ROR - MERITOR SAF STEYR TECMA WEWELER</p>
<p>D287/A</p> <p>Pistone in composito Composite piston</p>	<p>287.4.512</p>	<p>SN21502</p>	<p>LECITRAILER</p>

I nominativi dei costruttori e i relativi riferimenti originali citati nel presente catalogo sono riportati a puro titolo indicativo. I nostri prodotti non sono originali ma con essi intercambiabili.
The name of manufacturers and the o.e. references mentioned in this catalogue are given for cross-reference purposes only. Our products are not original but interchangeable with.

TIPO - TYPE	CODICE - CODE	RIFERIMENTO ORIGINALE - O. E. REFERENCE										
<p>D287/B</p>	<p>287.2.580</p>	<p>NEW</p> <table border="1"> <tr> <td>5805710</td> <td>CARDI</td> </tr> </table>	5805710	CARDI								
5805710	CARDI											
<p>D287/B</p>	<p>287.4.580</p>	<table border="1"> <tr> <td>UJB0305</td> <td>FRUEHAUF</td> </tr> <tr> <td>21221349</td> <td>ROR - MERITOR</td> </tr> <tr> <td>3229002400</td> <td>SAF</td> </tr> <tr> <td>H25000361</td> <td>SAMRO</td> </tr> <tr> <td>US 07380F</td> <td>WEWELER</td> </tr> </table>	UJB0305	FRUEHAUF	21221349	ROR - MERITOR	3229002400	SAF	H25000361	SAMRO	US 07380F	WEWELER
UJB0305	FRUEHAUF											
21221349	ROR - MERITOR											
3229002400	SAF											
H25000361	SAMRO											
US 07380F	WEWELER											
<p>D287/B</p>	<p>287.4.581</p>	<table border="1"> <tr> <td>M001464</td> <td>FRUEHAUF</td> </tr> <tr> <td>1006552</td> <td>ZORZI</td> </tr> </table>	M001464	FRUEHAUF	1006552	ZORZI						
M001464	FRUEHAUF											
1006552	ZORZI											

I nominativi dei costruttori e i relativi riferimenti originali citati nel presente catalogo sono riportati a puro titolo indicativo. I nostri prodotti non sono originali ma con essi intercambiabili.
The name of manufacturers and the o.e. references mentioned in this catalogue are given for cross-reference purposes only. Our products are not original but interchangeable with.

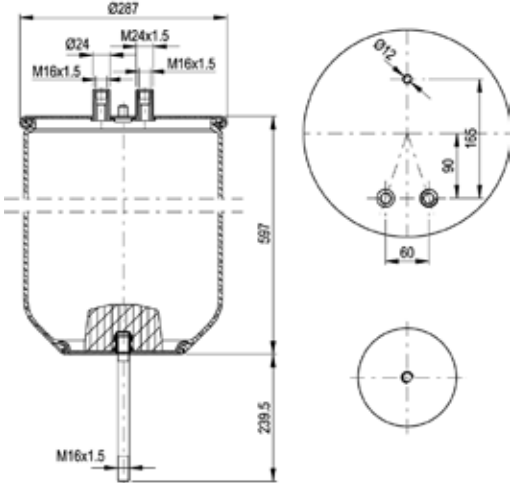
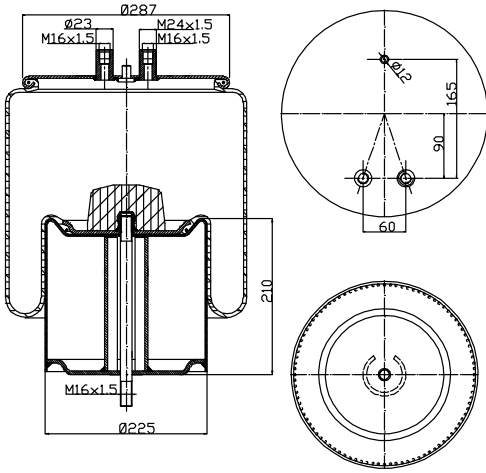
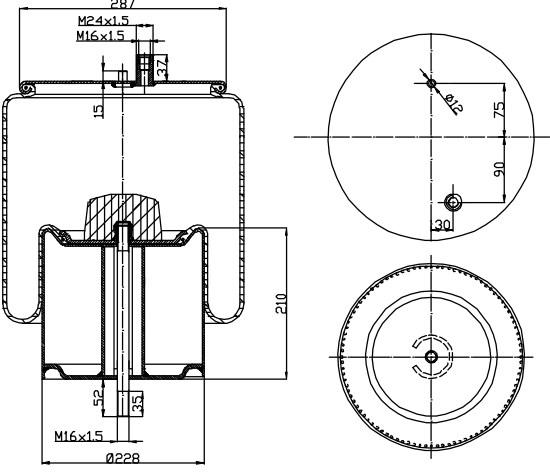

TIPO - TYPE	CODICE - CODE	RIFERIMENTO ORIGINALE - O. E. REFERENCE	
<p>D287/C</p> 	<p>287.0.601</p>	5010294307	RVI
		5001832067	RVI
<p>D287/C</p> 	<p>287.1.600</p>	5010294307 C	RVI
		5001832067	RVI
<p>D287/C</p> 	<p>287.1.602</p>	NEW	
		5010600328	RVI Magnum
		20726769	VOLVO

I nominativi dei costruttori e i relativi riferimenti originali citati nel presente catalogo sono riportati a puro titolo indicativo. I nostri prodotti non sono originali ma con essi intercambiabili.
 The name of manufacturers and the o.e. references mentioned in this catalogue are given for cross-reference purposes only. Our products are not original but interchangeable with.

TIPO - TYPE	CODICE - CODE	RIFERIMENTO ORIGINALE - O. E. REFERENCE	
<p>D287/C</p>	<p>287.1.603</p>	NEW	
		5010557355	RVI
		20722412	VOLVO
<p>D287/C</p>	<p>287.1.604</p>	NEW	
		3228103000	SAF
<p>D287/C</p>	<p>287.4.600</p>	XCM1331	FRUEHAUF
		M060770	FRUEHAUF
		Y507782	HENDRICKSON
		21222673	ROR - MERITOR
		21227225	ROR - MERITOR
		3229000601	SAF
		3229000500	SAF
		3229001300	SAF
		US 96681F	WEWELER
		US 7385F	WEWELER

I nominativi dei costruttori e i relativi riferimenti originali citati nel presente catalogo sono riportati a puro titolo indicativo. I nostri prodotti non sono originali ma con essi intercambiabili.
 The name of manufacturers and the o.e. references mentioned in this catalogue are given for cross-reference purposes only. Our products are not original but interchangeable with.



TIPO - TYPE	CODICE - CODE	RIFERIMENTO ORIGINALE - O. E. REFERENCE	
<p>D287/C</p>	<p>287.4.601</p>	3229263000	SAF
		3229003000	SAF
		2926V	SAF
<p>D287/C</p>	<p>287.4.601/1</p>	NEW	
		3228003000	SAF
<p>D287/D</p>	<p>287.2.670</p>	11815	OMAR
		70100027	PEZZAIOLI
		112010	ROLFO
		1006557	ZORZI

I nominativi dei costruttori e i relativi riferimenti originali citati nel presente catalogo sono riportati a puro titolo indicativo. I nostri prodotti non sono originali ma con essi intercambiabili.
 The name of manufacturers and the o.e. references mentioned in this catalogue are given for cross-reference purposes only. Our products are not original but interchangeable with.

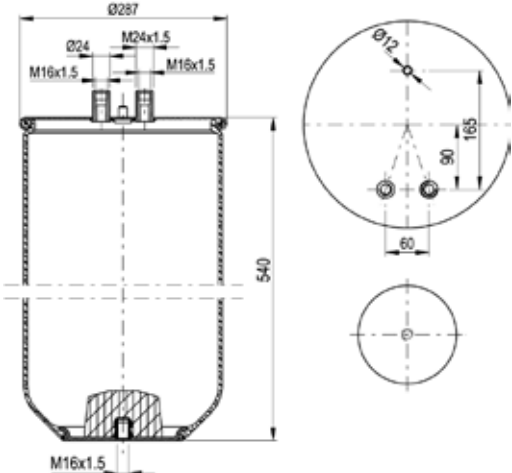
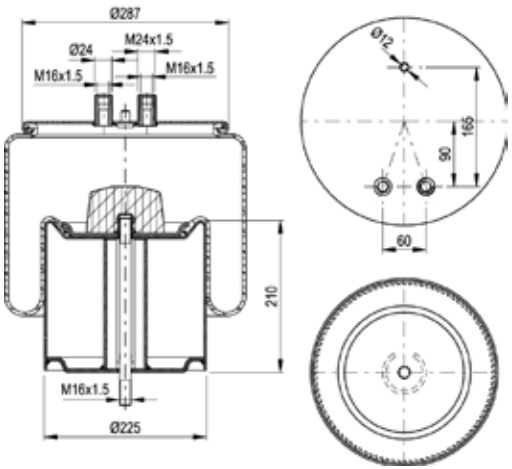
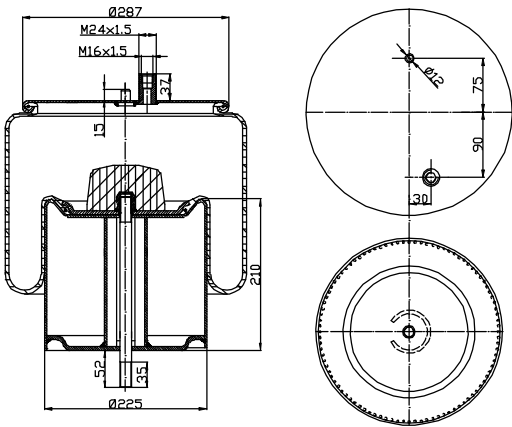

TIPO - TYPE	CODICE - CODE	RIFERIMENTO ORIGINALE - O. E. REFERENCE	
<p>D287/E</p> 	<p>287.0.541</p>	5011294308	RVI
		5011239971	RVI
<p>D287/E</p> 	<p>287.1.540</p>	5010239971	RVI
<p>D287/E</p> 	<p>287.1.541</p>	NEW	
		5010557356	RVI

I nominativi dei costruttori e i relativi riferimenti originali citati nel presente catalogo sono riportati a puro titolo indicativo. I nostri prodotti non sono originali ma con essi intercambiabili.
 The name of manufacturers and the o.e. references mentioned in this catalogue are given for cross-reference purposes only. Our products are not original but interchangeable with.

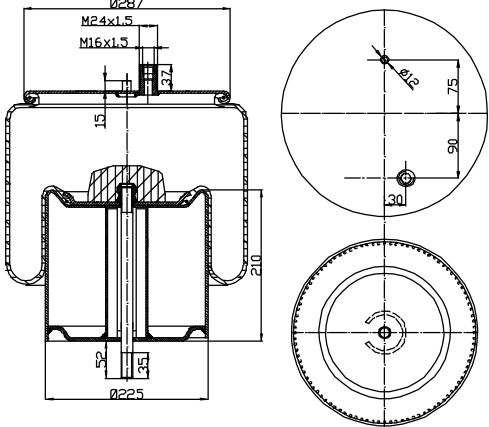
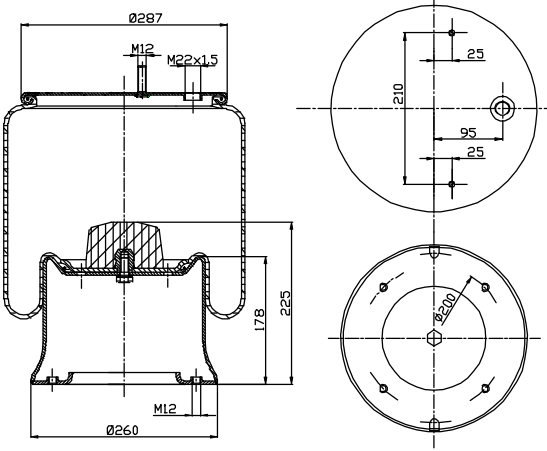
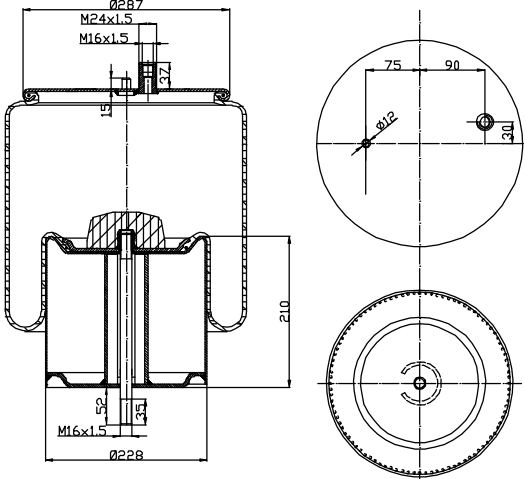

TIPO - TYPE	CODICE - CODE	RIFERIMENTO ORIGINALE - O. E. REFERENCE						
<p style="text-align: center;">D287/E</p> 	<p style="text-align: center;">287.1.542</p>	<p style="text-align: center;">NEW</p> <table border="1" data-bbox="801 383 1520 443"> <tr> <td>5010600439</td> <td>RVI</td> </tr> <tr> <td>20726769</td> <td>VOLVO</td> </tr> </table>	5010600439	RVI	20726769	VOLVO		
5010600439	RVI							
20726769	VOLVO							
<p style="text-align: center;">D287/E</p> 	<p style="text-align: center;">287.4.540</p>	<p style="text-align: center;">NEW</p> <table border="1" data-bbox="801 947 1520 1008"> <tr> <td>015323</td> <td>SCHMITZ</td> </tr> <tr> <td>US04028</td> <td>WEWELER</td> </tr> </table>	015323	SCHMITZ	US04028	WEWELER		
015323	SCHMITZ							
US04028	WEWELER							
<p style="text-align: center;">D287/H</p> 	<p style="text-align: center;">287.0.603</p>	<p style="text-align: center;">REPLACE 282.0.601</p> <table border="1" data-bbox="801 1512 1520 1592"> <tr> <td>1440294</td> <td>SCANIA</td> </tr> <tr> <td>1379393</td> <td>SCANIA</td> </tr> <tr> <td>1379392</td> <td>SCANIA</td> </tr> </table>	1440294	SCANIA	1379393	SCANIA	1379392	SCANIA
1440294	SCANIA							
1379393	SCANIA							
1379392	SCANIA							

I nominativi dei costruttori e i relativi riferimenti originali citati nel presente catalogo sono riportati a puro titolo indicativo. I nostri prodotti non sono originali ma con essi intercambiabili.
The name of manufacturers and the o.e. references mentioned in this catalogue are given for cross-reference purposes only. Our products are not original but interchangeable with.

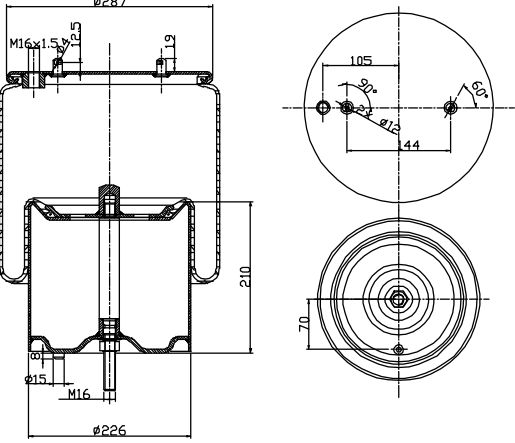
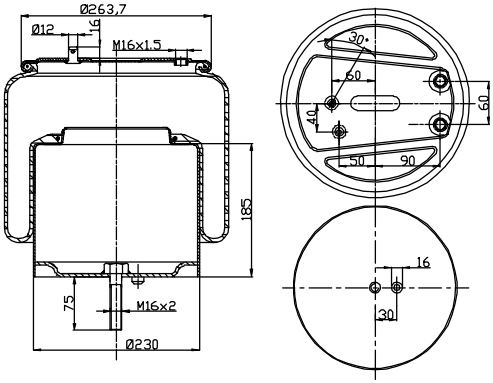
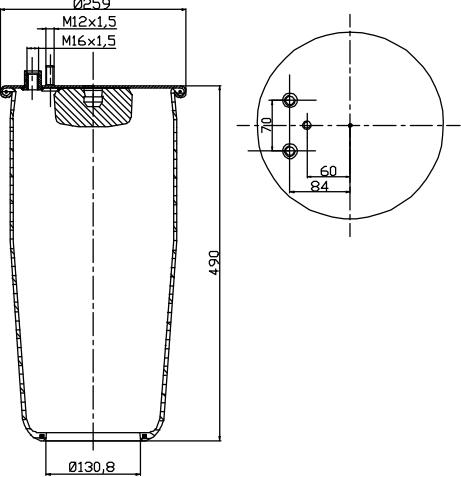

TIPO - TYPE	CODICE - CODE	RIFERIMENTO ORIGINALE - O. E. REFERENCE							
<p>D287/H</p> 	<p>287.1.606</p>	<p>REPLACE 282.1.600</p> <table border="1" data-bbox="721 383 1442 465"> <tr> <td>1440294</td> <td>SCANIA</td> </tr> <tr> <td>1379393</td> <td>SCANIA</td> </tr> <tr> <td>1379392</td> <td>SCANIA</td> </tr> </table>		1440294	SCANIA	1379393	SCANIA	1379392	SCANIA
1440294	SCANIA								
1379393	SCANIA								
1379392	SCANIA								
<p>D287/SC</p> 	<p>287.1.480</p>	<p>NEW</p> <table border="1" data-bbox="721 943 1442 969"> <tr> <td>1434933</td> <td>SCANIA V TRUCK</td> </tr> </table>		1434933	SCANIA V TRUCK				
1434933	SCANIA V TRUCK								
<p>C289/M</p> 	<p>289.0.512</p>	<table border="1" data-bbox="721 1507 1442 1534"> <tr> <td>81.43601.0151</td> <td>MAN TGA</td> </tr> </table>		81.43601.0151	MAN TGA				
81.43601.0151	MAN TGA								

I nominativi dei costruttori e i relativi riferimenti originali citati nel presente catalogo sono riportati a puro titolo indicativo. I nostri prodotti non sono originali ma con essi intercambiabili.
 The name of manufacturers and the o.e. references mentioned in this catalogue are given for cross-reference purposes only. Our products are not original but interchangeable with.



TIPO - TYPE	CODICE - CODE	RIFERIMENTO ORIGINALE - O. E. REFERENCE				
<p>C289/M</p>	<p>289.1.510</p>	<table border="1"> <tr> <td data-bbox="799 383 1002 409">81.43601.6036</td> <td data-bbox="1002 383 1525 409">MAN TGA</td> </tr> </table>	81.43601.6036	MAN TGA		
81.43601.6036	MAN TGA					
<p>C289/M</p>	<p>289.1.513</p>	<p>NEW</p> <table border="1"> <tr> <td data-bbox="799 947 1002 974">81.43600.6041</td> <td data-bbox="1002 947 1525 974">MAN TGA</td> </tr> <tr> <td data-bbox="799 974 1002 1001">81.43601.6038</td> <td data-bbox="1002 974 1525 1001">MAN TGA</td> </tr> </table>	81.43600.6041	MAN TGA	81.43601.6038	MAN TGA
81.43600.6041	MAN TGA					
81.43601.6038	MAN TGA					
<p>C289/M1</p>	<p>289.0.411</p>	<p>NEW</p> <table border="1"> <tr> <td data-bbox="799 1507 1002 1534">81.43601.0160</td> <td data-bbox="1002 1507 1525 1534">MAN</td> </tr> </table>	81.43601.0160	MAN		
81.43601.0160	MAN					

I nominativi dei costruttori e i relativi riferimenti originali citati nel presente catalogo sono riportati a puro titolo indicativo. I nostri prodotti non sono originali ma con essi intercambiabili.
 The name of manufacturers and the o.e. references mentioned in this catalogue are given for cross-reference purposes only. Our products are not original but interchangeable with.



TIPO - TYPE	CODICE - CODE	RIFERIMENTO ORIGINALE - O. E. REFERENCE				
<p>C289/M1</p>	<p>289.1.410</p>	<p>NEW</p> <table border="1" data-bbox="721 383 1444 409"> <tr> <td>81.43600.6044</td> <td>MAN</td> </tr> </table>	81.43600.6044	MAN		
81.43600.6044	MAN					
<p>D290</p>	<p>290.1.420</p>	<p>NEW</p> <table border="1" data-bbox="721 947 1444 1001"> <tr> <td>-</td> <td>IRISBUS</td> </tr> <tr> <td>41026260</td> <td>IVECO</td> </tr> </table>	-	IRISBUS	41026260	IVECO
-	IRISBUS					
41026260	IVECO					
<p>D290/B</p>	<p>290.1.394</p>	<p>NEW</p> <table border="1" data-bbox="721 1512 1444 1565"> <tr> <td>-</td> <td>IRISBUS</td> </tr> <tr> <td>4102656</td> <td>IVECO</td> </tr> </table>	-	IRISBUS	4102656	IVECO
-	IRISBUS					
4102656	IVECO					

I nominativi dei costruttori e i relativi riferimenti originali citati nel presente catalogo sono riportati a puro titolo indicativo. I nostri prodotti non sono originali ma con essi intercambiabili.
 The name of manufacturers and the o.e. references mentioned in this catalogue are given for cross-reference purposes only. Our products are not original but interchangeable with.

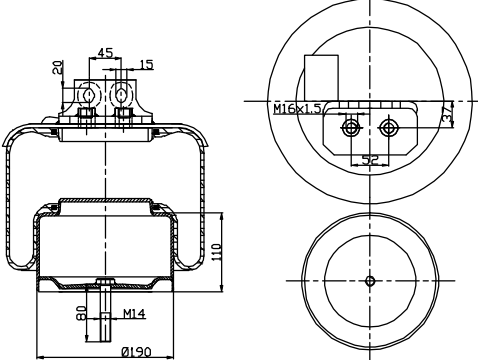
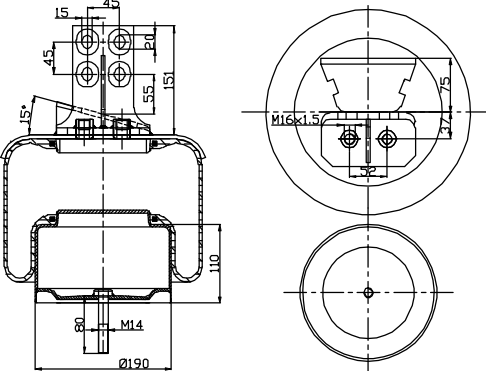
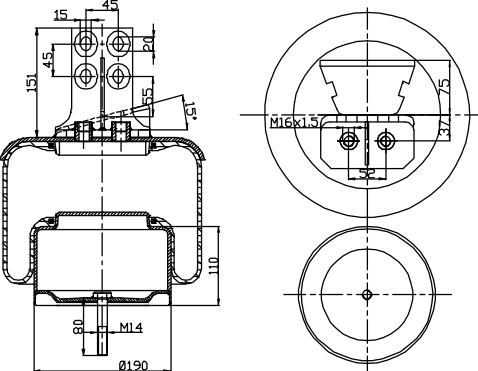

TIPO - TYPE	CODICE - CODE	RIFERIMENTO ORIGINALE - O. E. REFERENCE				
<p>D290/B</p> 	<p>290.1.395</p>	<p>NEW</p> <table border="1" data-bbox="801 383 1520 439"> <tr> <td>-</td> <td>IRISBUS</td> </tr> <tr> <td>4102657</td> <td>IVECO</td> </tr> </table>	-	IRISBUS	4102657	IVECO
-	IRISBUS					
4102657	IVECO					
<p>D290/B</p> 	<p>290.1.396</p>	<p>NEW</p> <table border="1" data-bbox="801 943 1520 969"> <tr> <td>41026285</td> <td>IVECO STRALIS</td> </tr> </table>	41026285	IVECO STRALIS		
41026285	IVECO STRALIS					
<p>D290/B</p> 	<p>290.1.397</p>	<p>NEW</p> <table border="1" data-bbox="801 1503 1520 1529"> <tr> <td>41026286</td> <td>IVECO STRALIS</td> </tr> </table>	41026286	IVECO STRALIS		
41026286	IVECO STRALIS					

I nominativi dei costruttori e i relativi riferimenti originali citati nel presente catalogo sono riportati a puro titolo indicativo. I nostri prodotti non sono originali ma con essi intercambiabili.
 The name of manufacturers and the o.e. references mentioned in this catalogue are given for cross-reference purposes only. Our products are not original but interchangeable with.

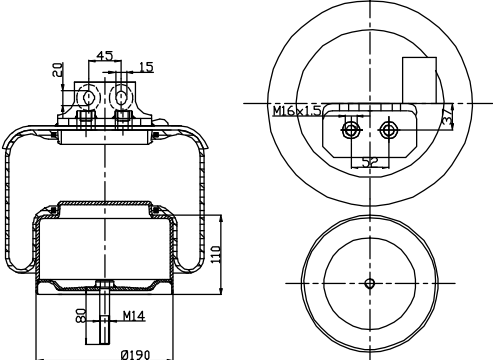
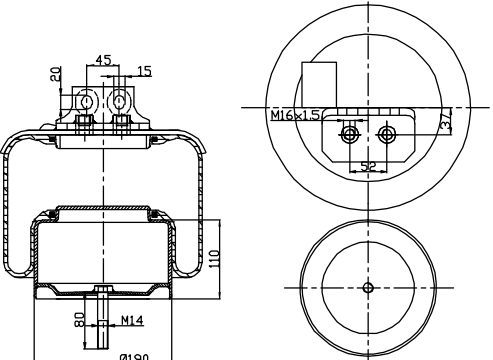
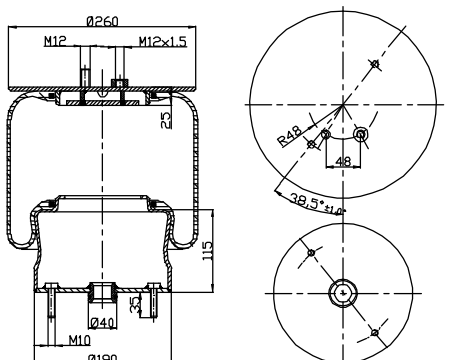

TIPO - TYPE	CODICE - CODE	RIFERIMENTO ORIGINALE - O. E. REFERENCE	
D290/B 	290.1.398	NEW IVECO EUROTECH 440 STRALIS 440 41031242 IVECO EUROSTAR 400/440	
D290/B 	290.1.399	NEW IVECO EUROTECH 440 STRALIS 440 41031243 IVECO EUROSTAR 400/440	
D290/B 	290.2.390	5006223351 IVECO BUS 491 (da 4/04 in poi) (Posteriore / Rear)	

I nominativi dei costruttori e i relativi riferimenti originali citati nel presente catalogo sono riportati a puro titolo indicativo. I nostri prodotti non sono originali ma con essi intercambiabili.
 The name of manufacturers and the o.e. references mentioned in this catalogue are given for cross-reference purposes only. Our products are not original but interchangeable with.



TIPO - TYPE	CODICE - CODE	RIFERIMENTO ORIGINALE - O. E. REFERENCE
<p>D290/B</p>	<p>290.2.391</p>	<p>5006223352 IVECO BUS 491 (da 4/04 in poi) (Posteriore / Rear)</p>
<p>D290/BR</p>	<p>290.0.392</p>	<p>NEW</p> <p>42559765 IVECO STRALIS</p>
<p>D290/BR</p>	<p>290.0.393</p>	<p>NEW</p> <p>42559766 IVECO STRALIS</p>

I nominativi dei costruttori e i relativi riferimenti originali citati nel presente catalogo sono riportati a puro titolo indicativo. I nostri prodotti non sono originali ma con essi intercambiabili.
 The name of manufacturers and the o.e. references mentioned in this catalogue are given for cross-reference purposes only. Our products are not original but interchangeable with.



TIPO - TYPE	CODICE - CODE	RIFERIMENTO ORIGINALE - O. E. REFERENCE	
<p>D290/BR</p>	<p>290.0.394</p>	NEW	
		42559767	IVECO STRALIS
<p>D290/BR</p>	<p>290.0.395</p>	NEW	
		42559768	IVECO STRALIS
<p>D290/BR</p>		290.1.390	
		41270462	IVECO STRALIS Ant. Post. sinistro / Front left

I nominativi dei costruttori e i relativi riferimenti originali citati nel presente catalogo sono riportati a puro titolo indicativo. I nostri prodotti non sono originali ma con essi intercambiabili.
 The name of manufacturers and the o.e. references mentioned in this catalogue are given for cross-reference purposes only. Our products are not original but interchangeable with.



TIPO - TYPE	CODICE - CODE	RIFERIMENTO ORIGINALE - O. E. REFERENCE
<p>D290/BR</p>	<p>290.1.391</p>	<p>41270463 IVECO STRALIS Ant. Post. destro / Front right</p>
<p>D290/BR</p>	<p>290.1.392</p>	<p>41270465 IVECO STRALIS Post. Post. sinistro / Rear left</p>
<p>D290/BR</p>	<p>290.1.393</p>	<p>41270466 IVECO STRALIS Post. Post. Destro / Rear right</p>

I nominativi dei costruttori e i relativi riferimenti originali citati nel presente catalogo sono riportati a puro titolo indicativo. I nostri prodotti non sono originali ma con essi intercambiabili.
 The name of manufacturers and the o.e. references mentioned in this catalogue are given for cross-reference purposes only. Our products are not original but interchangeable with.

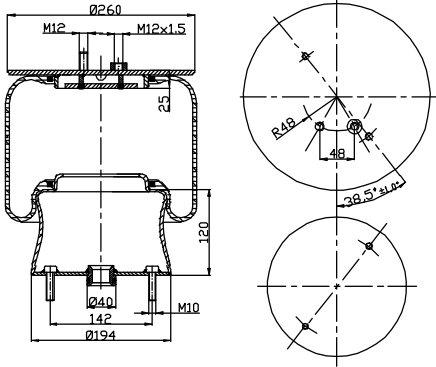
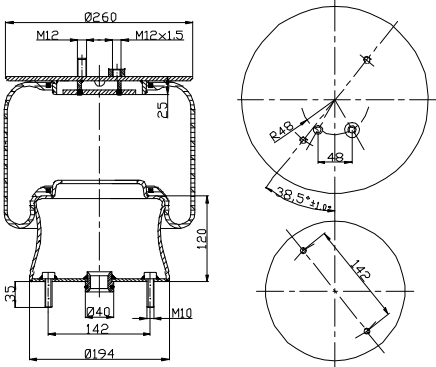
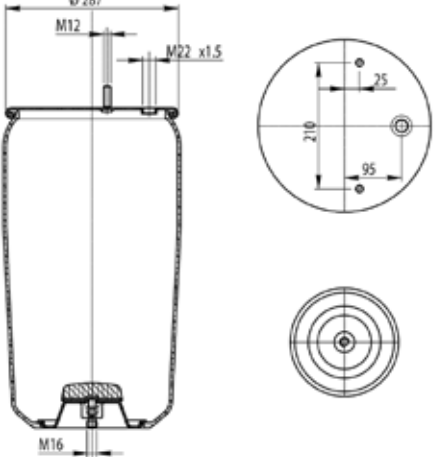

TIPO - TYPE	CODICE - CODE	RIFERIMENTO ORIGINALE - O. E. REFERENCE					
<p>D290/E</p> 	<p>290.2.340</p>	<table border="1"> <tr> <td data-bbox="722 383 927 409">99482949</td> <td data-bbox="927 383 1444 409">IVECO BUS 491 Cityclass (Posteriore / Rear)</td> </tr> </table>		99482949	IVECO BUS 491 Cityclass (Posteriore / Rear)		
99482949	IVECO BUS 491 Cityclass (Posteriore / Rear)						
<p>D290/E</p> 	<p>290.2.341</p>	<table border="1"> <tr> <td data-bbox="722 947 927 974">99482948</td> <td data-bbox="927 947 1444 974">IVECO BUS 491 Cityclass (Posteriore / Rear)</td> </tr> </table>		99482948	IVECO BUS 491 Cityclass (Posteriore / Rear)		
99482948	IVECO BUS 491 Cityclass (Posteriore / Rear)						
<p>C292</p> 	<p>292.0.531</p>	<table border="1"> <tr> <td data-bbox="722 1512 927 1538">05.429.40.02.0</td> <td data-bbox="927 1512 1444 1538">B.P.W. 36</td> </tr> <tr> <td data-bbox="722 1538 927 1565">05.429.40.01.0</td> <td data-bbox="927 1538 1444 1565">B.P.W. 36</td> </tr> </table>		05.429.40.02.0	B.P.W. 36	05.429.40.01.0	B.P.W. 36
05.429.40.02.0	B.P.W. 36						
05.429.40.01.0	B.P.W. 36						

I nominativi dei costruttori e i relativi riferimenti originali citati nel presente catalogo sono riportati a puro titolo indicativo. I nostri prodotti non sono originali ma con essi intercambiabili.
 The name of manufacturers and the o.e. references mentioned in this catalogue are given for cross-reference purposes only. Our products are not original but interchangeable with.



TIPO - TYPE	CODICE - CODE	RIFERIMENTO ORIGINALE - O. E. REFERENCE														
<p>C292</p>	<p>292.2.530</p>	<table border="1"> <tr><td>05.429.41.36.1</td><td>B.P.W. 36</td></tr> <tr><td>05.429.41.21.1</td><td>B.P.W. 36</td></tr> <tr><td>05.429.40.61.1</td><td>B.P.W. 36</td></tr> <tr><td>05.429.40.47.1</td><td>B.P.W. 36</td></tr> <tr><td>05.429.40.39.1</td><td>B.P.W. 36</td></tr> <tr><td>05.429.40.14.1</td><td>B.P.W. 36</td></tr> <tr><td>05.429.40.08.1</td><td>B.P.W. 36</td></tr> </table>	05.429.41.36.1	B.P.W. 36	05.429.41.21.1	B.P.W. 36	05.429.40.61.1	B.P.W. 36	05.429.40.47.1	B.P.W. 36	05.429.40.39.1	B.P.W. 36	05.429.40.14.1	B.P.W. 36	05.429.40.08.1	B.P.W. 36
05.429.41.36.1	B.P.W. 36															
05.429.41.21.1	B.P.W. 36															
05.429.40.61.1	B.P.W. 36															
05.429.40.47.1	B.P.W. 36															
05.429.40.39.1	B.P.W. 36															
05.429.40.14.1	B.P.W. 36															
05.429.40.08.1	B.P.W. 36															
<p>C292</p>	<p>292.2.531</p>	<table border="1"> <tr><td>-</td><td>B.P.W. 36</td></tr> </table>	-	B.P.W. 36												
-	B.P.W. 36															
<p>C292</p> <p>Pistone in composito Composite piston</p>	<p>292.2.532</p>	<table border="1"> <tr><td>05.801.21.31.0</td><td>B.P.W. 36</td></tr> <tr><td>05.801.21.32.0</td><td>B.P.W. 36</td></tr> <tr><td>05.429.43.51.0</td><td>B.P.W. 36</td></tr> <tr><td>05.429.41.36.1</td><td>B.P.W. 36</td></tr> <tr><td>05.429.41.21.1</td><td>B.P.W. 36</td></tr> <tr><td>05.429.40.08.1</td><td>B.P.W. 36</td></tr> </table>	05.801.21.31.0	B.P.W. 36	05.801.21.32.0	B.P.W. 36	05.429.43.51.0	B.P.W. 36	05.429.41.36.1	B.P.W. 36	05.429.41.21.1	B.P.W. 36	05.429.40.08.1	B.P.W. 36		
05.801.21.31.0	B.P.W. 36															
05.801.21.32.0	B.P.W. 36															
05.429.43.51.0	B.P.W. 36															
05.429.41.36.1	B.P.W. 36															
05.429.41.21.1	B.P.W. 36															
05.429.40.08.1	B.P.W. 36															

I nominativi dei costruttori e i relativi riferimenti originali citati nel presente catalogo sono riportati a puro titolo indicativo. I nostri prodotti non sono originali ma con essi intercambiabili.
 The name of manufacturers and the o.e. references mentioned in this catalogue are given for cross-reference purposes only. Our products are not original but interchangeable with.

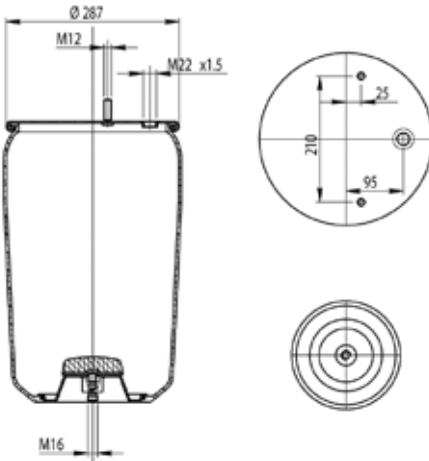
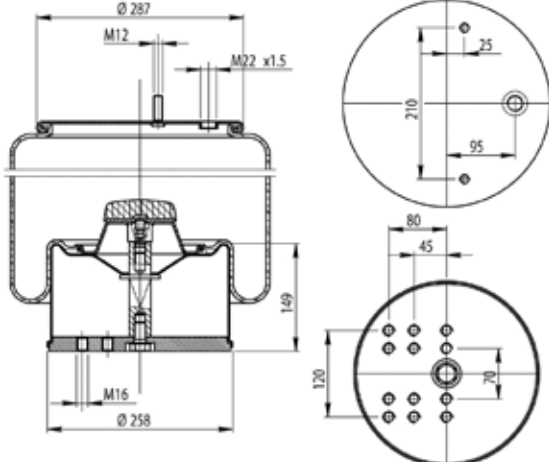
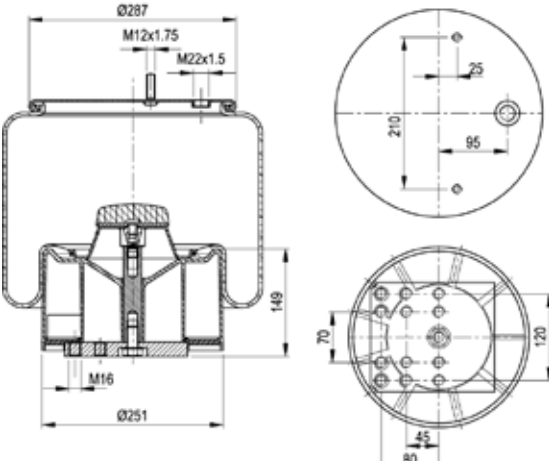

TIPO - TYPE	CODICE - CODE	RIFERIMENTO ORIGINALE - O. E. REFERENCE							
<p>C292/A</p> 	<p>292.0.461</p>	<table border="1"> <tr> <td data-bbox="721 380 933 414">05.429.41.01.0</td> <td data-bbox="933 380 1444 414">B.P.W. 36K</td> </tr> </table>		05.429.41.01.0	B.P.W. 36K				
05.429.41.01.0	B.P.W. 36K								
<p>C292/A</p> 	<p>292.2.460</p>	<table border="1"> <tr> <td data-bbox="721 940 933 974">05.429.41.22.1</td> <td data-bbox="933 940 1444 974">B.P.W. 36K</td> </tr> </table>		05.429.41.22.1	B.P.W. 36K				
05.429.41.22.1	B.P.W. 36K								
<p>C292/A</p>  <p>Pistone in composito Composite piston</p>	<p>292.2.462</p>	<table border="1"> <tr> <td data-bbox="721 1500 933 1534">05.801.21.29.0</td> <td data-bbox="933 1500 1444 1534">B.P.W. 36K</td> </tr> <tr> <td data-bbox="721 1534 933 1568">05.801.21.28.0</td> <td data-bbox="933 1534 1444 1568">B.P.W. 36K</td> </tr> <tr> <td data-bbox="721 1568 933 1601">05.429.43.41.0</td> <td data-bbox="933 1568 1444 1601">B.P.W. 36K</td> </tr> </table>		05.801.21.29.0	B.P.W. 36K	05.801.21.28.0	B.P.W. 36K	05.429.43.41.0	B.P.W. 36K
05.801.21.29.0	B.P.W. 36K								
05.801.21.28.0	B.P.W. 36K								
05.429.43.41.0	B.P.W. 36K								

I nominativi dei costruttori e i relativi riferimenti originali citati nel presente catalogo sono riportati a puro titolo indicativo. I nostri prodotti non sono originali ma con essi intercambiabili.
 The name of manufacturers and the o.e. references mentioned in this catalogue are given for cross-reference purposes only. Our products are not original but interchangeable with.



TIPO - TYPE	CODICE - CODE	RIFERIMENTO ORIGINALE - O. E. REFERENCE										
<p>C292/AR</p>	<p>292.2.460/1</p>	<table border="1"> <tr> <td>03001537</td> <td>ADIGE</td> </tr> </table>	03001537	ADIGE								
03001537	ADIGE											
<p>C292/B</p>	<p>292.0.601</p>	<table border="1"> <tr> <td>05.429.41.69.0</td> <td>B.P.W. 36-1</td> </tr> <tr> <td>05.429.41.38.0</td> <td>B.P.W. 36-1</td> </tr> <tr> <td>05.429.40.58.0</td> <td>B.P.W. 36-1</td> </tr> <tr> <td>05.429.40.44.0</td> <td>B.P.W. 36-1</td> </tr> <tr> <td>05.429.40.05.0</td> <td>B.P.W. 36-1</td> </tr> </table>	05.429.41.69.0	B.P.W. 36-1	05.429.41.38.0	B.P.W. 36-1	05.429.40.58.0	B.P.W. 36-1	05.429.40.44.0	B.P.W. 36-1	05.429.40.05.0	B.P.W. 36-1
05.429.41.69.0	B.P.W. 36-1											
05.429.41.38.0	B.P.W. 36-1											
05.429.40.58.0	B.P.W. 36-1											
05.429.40.44.0	B.P.W. 36-1											
05.429.40.05.0	B.P.W. 36-1											
<p>C292/B</p>	<p>292.2.600</p>	<p>NEW</p> <table border="1"> <tr> <td>-</td> <td>B.P.W. 36-1</td> </tr> </table>	-	B.P.W. 36-1								
-	B.P.W. 36-1											

I nominativi dei costruttori e i relativi riferimenti originali citati nel presente catalogo sono riportati a puro titolo indicativo. I nostri prodotti non sono originali ma con essi intercambiabili.
 The name of manufacturers and the o.e. references mentioned in this catalogue are given for cross-reference purposes only. Our products are not original but interchangeable with.

TIPO - TYPE	CODICE - CODE	RIFERIMENTO ORIGINALE - O. E. REFERENCE					
<p>C292/B</p> <p>Pistone in composito Composite piston</p>	<p>292.2.602</p>	<p>NEW</p> <table border="1"> <tr> <td>05.429.43.45.0</td> <td>B.P.W. 36-1</td> </tr> <tr> <td>46311033</td> <td>BERTOJA</td> </tr> </table>		05.429.43.45.0	B.P.W. 36-1	46311033	BERTOJA
05.429.43.45.0	B.P.W. 36-1						
46311033	BERTOJA						
<p>C292/S</p>	<p>292.0.533</p>	<table border="1"> <tr> <td>166252</td> <td>GIGANT</td> </tr> <tr> <td>166217</td> <td>GIGANT</td> </tr> </table>		166252	GIGANT	166217	GIGANT
166252	GIGANT						
166217	GIGANT						
<p>C292/S</p>	<p>292.1.533</p>	<table border="1"> <tr> <td>166252</td> <td>GIGANT</td> </tr> </table>		166252	GIGANT		
166252	GIGANT						

I nominativi dei costruttori e i relativi riferimenti originali citati nel presente catalogo sono riportati a puro titolo indicativo. I nostri prodotti non sono originali ma con essi intercambiabili.
 The name of manufacturers and the o.e. references mentioned in this catalogue are given for cross-reference purposes only. Our products are not original but interchangeable with.



TIPO - TYPE	CODICE - CODE	RIFERIMENTO ORIGINALE - O. E. REFERENCE							
<p>C292/S</p>	<p>292.1.534</p>	<table border="1"> <tr> <td data-bbox="798 383 1002 409">166217</td> <td data-bbox="1002 383 1516 409">GIGANT</td> </tr> </table>		166217	GIGANT				
166217	GIGANT								
<p>C293</p>	<p>293.0.511</p>	<table border="1"> <tr> <td data-bbox="798 943 1002 969">05.429.41.24.1</td> <td data-bbox="1002 943 1516 969">B.P.W. 30</td> </tr> <tr> <td data-bbox="798 969 1002 996">05.429.40.03.0</td> <td data-bbox="1002 969 1516 996">B.P.W. 30</td> </tr> <tr> <td data-bbox="798 996 1002 1023">01.429.40.28.1</td> <td data-bbox="1002 996 1516 1023">B.P.W. 30</td> </tr> </table>		05.429.41.24.1	B.P.W. 30	05.429.40.03.0	B.P.W. 30	01.429.40.28.1	B.P.W. 30
05.429.41.24.1	B.P.W. 30								
05.429.40.03.0	B.P.W. 30								
01.429.40.28.1	B.P.W. 30								
<p>C293</p>	<p>293.0.512</p>	<table border="1"> <tr> <td data-bbox="798 1503 1002 1529">-</td> <td data-bbox="1002 1503 1516 1529">B.P.W. 30</td> </tr> </table>		-	B.P.W. 30				
-	B.P.W. 30								

I nominativi dei costruttori e i relativi riferimenti originali citati nel presente catalogo sono riportati a puro titolo indicativo. I nostri prodotti non sono originali ma con essi intercambiabili.
 The name of manufacturers and the o.e. references mentioned in this catalogue are given for cross-reference purposes only. Our products are not original but interchangeable with.

TIPO - TYPE	CODICE - CODE	RIFERIMENTO ORIGINALE - O. E. REFERENCE	
<p>C293</p>	<p>293.0.513</p>	05.429.41.25.0	B.P.W. 30
<p>C293</p>	<p>293.0.514</p>	05.429.42.03.0	B.P.W. 30
<p>C293</p>	<p>293.2.510</p>	05.429.41.37.1	B.P.W. 30
		05.429.41.28.1	B.P.W. 30
		05.429.41.24.1	B.P.W. 30
		05.429.40.59.1	B.P.W. 30
		05.429.40.52.1	B.P.W. 30
		05.429.40.28.1	B.P.W. 30
		05.429.40.09.1	B.P.W. 30

I nominativi dei costruttori e i relativi riferimenti originali citati nel presente catalogo sono riportati a puro titolo indicativo. I nostri prodotti non sono originali ma con essi intercambiabili.
 The name of manufacturers and the o.e. references mentioned in this catalogue are given for cross-reference purposes only. Our products are not original but interchangeable with.



TIPO - TYPE	CODICE - CODE	RIFERIMENTO ORIGINALE - O. E. REFERENCE	
<p>C293</p> <p>Pistone in composito Composite piston</p>	<p>293.2.512</p>	05.429.43.56.0	B.P.W. 30
		05.429.43.34.0	B.P.W. 30
		05.801.09.73.0	B.P.W. 30
		05.429.43.20.0	B.P.W. 30
		05.429.41.37.1	B.P.W. 30
		05.429.41.28.0	B.P.W. 30
		05.429.41.24.1	B.P.W. 30
		05.429.40.59.1	B.P.W. 30
		05.429.40.37.1	B.P.W. 30
		05.429.40.09.1	B.P.W. 30
<p>C293</p> <p>Pistone in composito Composite piston</p>	<p>293.2.513</p>	NEW	
		05.429.43.29.0	B.P.W. 30
<p>C293</p> <p>Pistone in composito Composite piston</p>	<p>293.2.514</p>	05.429.43.62.0	B.P.W. 30
		05.429.42.54.0	B.P.W. 30

I nominativi dei costruttori e i relativi riferimenti originali citati nel presente catalogo sono riportati a puro titolo indicativo. I nostri prodotti non sono originali ma con essi intercambiabili.
 The name of manufacturers and the o.e. references mentioned in this catalogue are given for cross-reference purposes only. Our products are not original but interchangeable with.

TIPO - TYPE	CODICE - CODE	RIFERIMENTO ORIGINALE - O. E. REFERENCE	
<p>C293</p> <p>Pistone in composito Composite piston</p>	<p>293.2.514/PE</p>	<p>70100048</p>	<p>PEZZAIOLI</p>
<p>C293/A</p>	<p>293.0.411</p>	<p>05.429.40.91.0</p>	<p>B.P.W. 30K</p>
<p>C293/A</p>	<p>293.0.412</p>	<p>05.429.41.77.0</p>	<p>B.P.W. 30K</p>

I nominativi dei costruttori e i relativi riferimenti originali citati nel presente catalogo sono riportati a puro titolo indicativo. I nostri prodotti non sono originali ma con essi intercambiabili.
 The name of manufacturers and the o.e. references mentioned in this catalogue are given for cross-reference purposes only. Our products are not original but interchangeable with.



TIPO - TYPE	CODICE - CODE	RIFERIMENTO ORIGINALE - O. E. REFERENCE
<p>C293/A</p>	<p>293.0.413</p>	<p>05.429.41.56.0 B.P.W. 30K</p>
<p>C293/A</p>	<p>293.0.414</p>	<p>05.429.42.04.0 B.P.W. 30K</p>
<p>C293/A</p>	<p>293.2.410</p>	<p>05.429.42.41.1 B.P.W. 30K</p>

I nominativi dei costruttori e i relativi riferimenti originali citati nel presente catalogo sono riportati a puro titolo indicativo. I nostri prodotti non sono originali ma con essi intercambiabili.
 The name of manufacturers and the o.e. references mentioned in this catalogue are given for cross-reference purposes only. Our products are not original but interchangeable with.



TIPO - TYPE	CODICE - CODE	RIFERIMENTO ORIGINALE - O. E. REFERENCE	
<p>C293/A</p> <p>Pistone in composito Composite piston</p>	<p>293.2.412</p>	<p>05.801.09.74.0</p>	<p>B.P.W. 30K</p>
		<p>05.429.43.21.0</p>	<p>B.P.W. 30K</p>
<p>C293/A</p> <p>Pistone in composito Composite piston</p>	<p>293.2.414</p>	<p>05.429.43.23.0</p>	<p>B.P.W. 30K</p>
<p>C293/A</p> <p>Pistone in composito Composite piston</p>	<p>293.2.414/PE</p>	<p>70100047</p>	<p>PEZZAIOLI</p>

I nominativi dei costruttori e i relativi riferimenti originali citati nel presente catalogo sono riportati a puro titolo indicativo. I nostri prodotti non sono originali ma con essi intercambiabili.
 The name of manufacturers and the o.e. references mentioned in this catalogue are given for cross-reference purposes only. Our products are not original but interchangeable with.



TIPO - TYPE	CODICE - CODE	RIFERIMENTO ORIGINALE - O. E. REFERENCE	
<p>C293/A</p> <p>Pistone in composito <i>Composite piston</i></p>	<p>293.2.415</p>	05.429.43.26.0	B.P.W. 30K
<p>C293/B</p>	<p>293.0.611</p>	05.429.40.75.0	B.P.W. 30-1
		05.429.40.72.0	B.P.W. 30-1
		04.429.40.76.0	B.P.W. 30-1
<p>C293/B</p> <p>Pistone in composito <i>Composite piston</i></p>	<p>293.2.612</p>	05.429.43.52.0	B.P.W. 30-1

I nominativi dei costruttori e i relativi riferimenti originali citati nel presente catalogo sono riportati a puro titolo indicativo. I nostri prodotti non sono originali ma con essi intercambiabili.
 The name of manufacturers and the o.e. references mentioned in this catalogue are given for cross-reference purposes only. Our products are not original but interchangeable with.

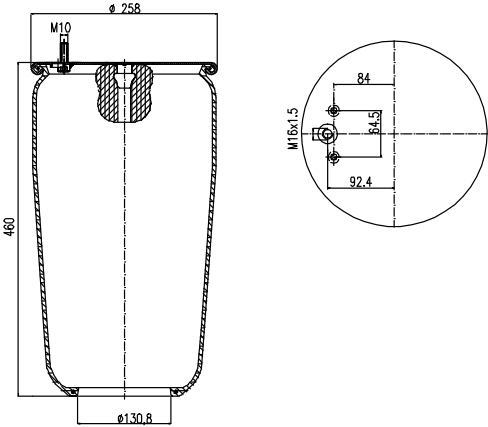
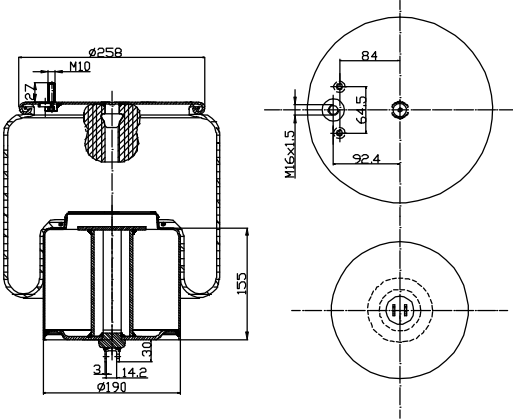
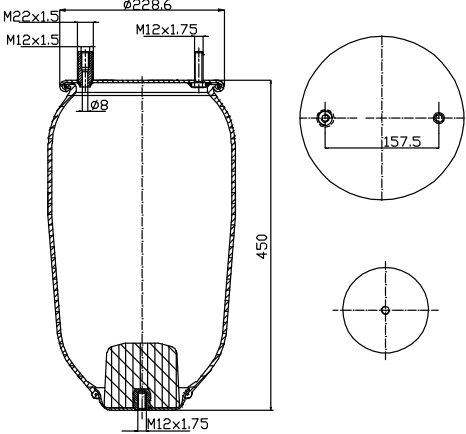

TIPO - TYPE	CODICE - CODE	RIFERIMENTO ORIGINALE - O. E. REFERENCE	
<p>C293/V</p> 	<p>293.0.461</p>		
		8158106	VOLVO
		1076595	VOLVO
<p>C293/V</p> 	<p>293.1.460</p>		
		1076594	VOLVO
<p>C294</p> 	<p>294.0.451</p>		
		2122442	ROR - MERITOR

I nominativi dei costruttori e i relativi riferimenti originali citati nel presente catalogo sono riportati a puro titolo indicativo. I nostri prodotti non sono originali ma con essi intercambiabili.
 The name of manufacturers and the o.e. references mentioned in this catalogue are given for cross-reference purposes only. Our products are not original but interchangeable with.



TIPO - TYPE	CODICE - CODE	RIFERIMENTO ORIGINALE - O. E. REFERENCE	
<p>C294</p>	<p>294.0.453</p>		
		751065	SCHMITZ
		US 6316F	WEWELER
<p>C294</p> <p>Pistone in composito Composite piston</p>	<p>294.1.450</p>		
		M060924	FRUEHAUF-ACERBI-TRAILOR
		-	SCHMITZ
		R915	SMB
<p>C294</p> <p>Pistone in composito Composite piston</p>	<p>294.1.451</p>		
		751065	SCHMITZ
		US 6316F	WEWELER

I nominativi dei costruttori e i relativi riferimenti originali citati nel presente catalogo sono riportati a puro titolo indicativo. I nostri prodotti non sono originali ma con essi intercambiabili.
 The name of manufacturers and the o.e. references mentioned in this catalogue are given for cross-reference purposes only. Our products are not original but interchangeable with.

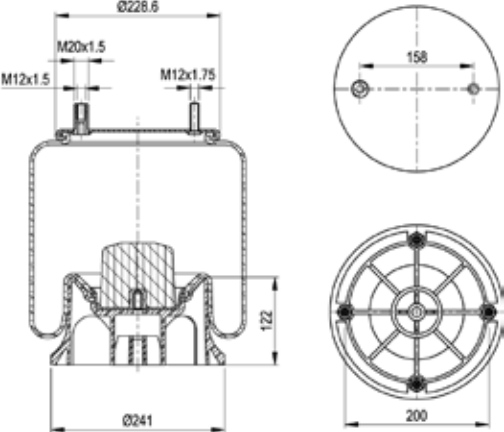
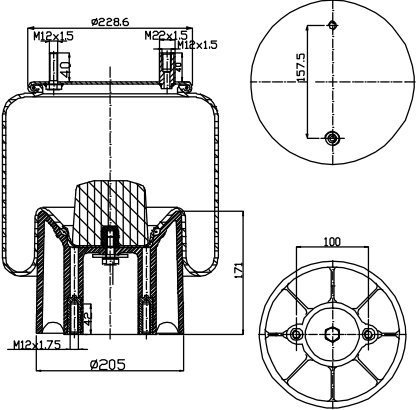
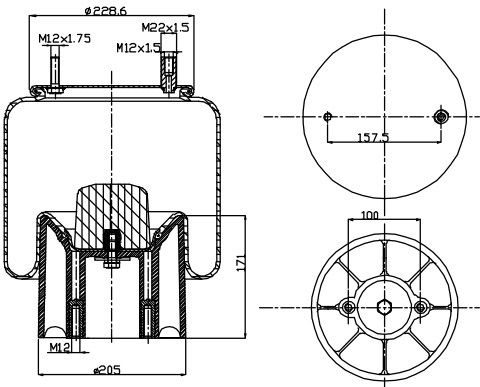

TIPO - TYPE	CODICE - CODE	RIFERIMENTO ORIGINALE - O. E. REFERENCE	
<p>C294</p>  <p>Pistone in composito <i>Composite piston</i></p>	<p>294.1.452</p>	<p>M078580</p>	<p>FRUEHAUF</p>
		<p>90557233</p>	<p>NEWAY</p>
<p>C294</p>  <p>Pistone in composito <i>Composite piston</i></p>	<p>294.2.450</p>	<p>15732</p>	<p>GRANNING</p>
		<p>21222442</p>	<p>ROR - MERITOR</p>
		<p>US07074</p>	<p>WEWELER</p>
<p>C294</p>  <p>Pistone in composito <i>Composite piston</i></p>	<p>294.2.450/1</p>	NEW	
		<p>US08840</p>	<p>WEWELER</p>

I nominativi dei costruttori e i relativi riferimenti originali citati nel presente catalogo sono riportati a puro titolo indicativo. I nostri prodotti non sono originali ma con essi intercambiabili.
 The name of manufacturers and the o.e. references mentioned in this catalogue are given for cross-reference purposes only. Our products are not original but interchangeable with.

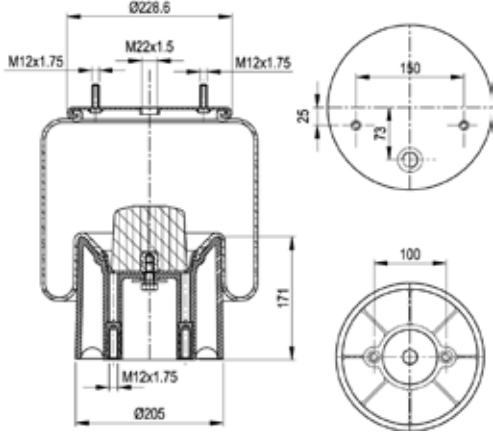
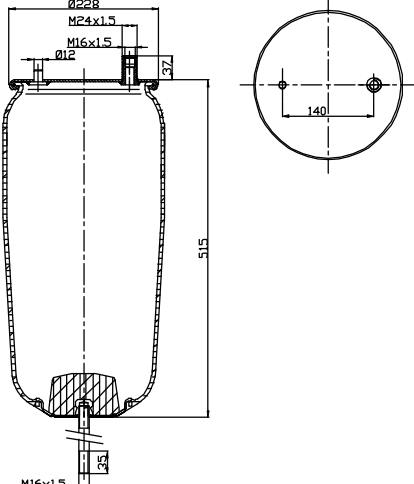
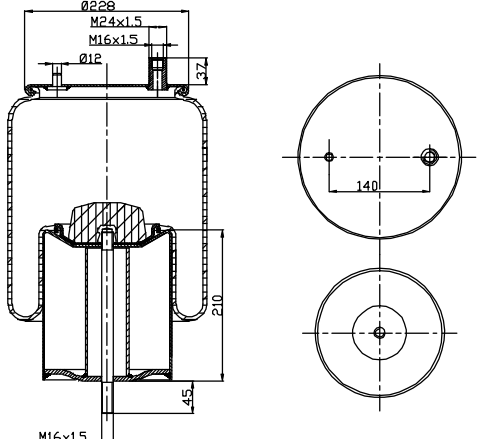

TIPO - TYPE	CODICE - CODE	RIFERIMENTO ORIGINALE - O. E. REFERENCE	
<p>C294</p>  <p>Pistone in composito <i>Composite piston</i></p>	<p>294.2.451</p>	21221307	ROR - MERITOR
<p>C294/C</p> 	<p>294.0.531</p>	NEW	
<p>C294/C</p> 	<p>294.1.530</p>	5001488070	RVI MAGNUM - PREMIUM
		5001294309	RVI MAGNUM - PREMIUM
		H2501122	SAMRO

I nominativi dei costruttori e i relativi riferimenti originali citati nel presente catalogo sono riportati a puro titolo indicativo. I nostri prodotti non sono originali ma con essi intercambiabili.
 The name of manufacturers and the o.e. references mentioned in this catalogue are given for cross-reference purposes only. Our products are not original but interchangeable with.

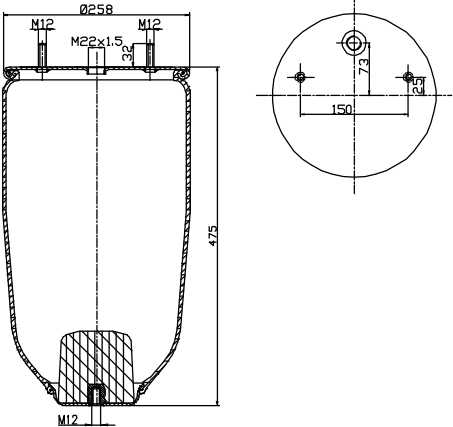
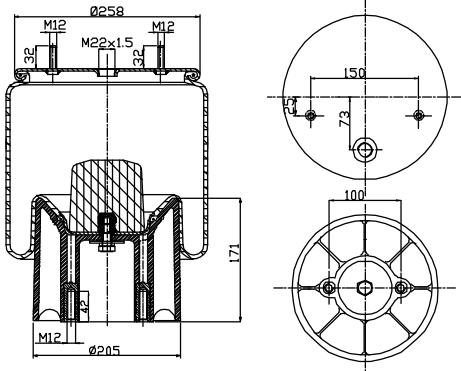
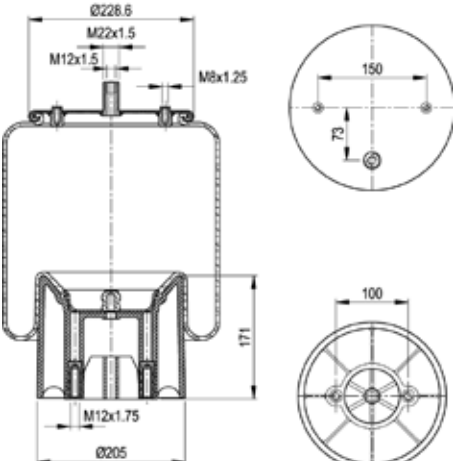
TIPO - TYPE	CODICE - CODE	RIFERIMENTO ORIGINALE - O. E. REFERENCE					
<p>C294/D</p> 	<p>294.0.455</p>	<p>NEW</p> <table border="1" data-bbox="726 383 1439 443"> <tr> <td>A9463281401</td> <td>MERCEDES</td> </tr> <tr> <td>21221307</td> <td>ROR - MERITOR</td> </tr> </table>		A9463281401	MERCEDES	21221307	ROR - MERITOR
A9463281401	MERCEDES						
21221307	ROR - MERITOR						
<p>C294/D</p>  <p>Pistone in composito Composite piston</p>	<p>294.2.454</p>	<p>NEW</p> <table border="1" data-bbox="726 943 1439 972"> <tr> <td>9463281401</td> <td>MERCEDES</td> </tr> </table>		9463281401	MERCEDES		
9463281401	MERCEDES						
<p>C294/HS</p>  <p>Pistone in composito Composite piston</p>	<p>294.1.500</p>	<table border="1" data-bbox="726 1503 1439 1532"> <tr> <td>US 86318F</td> <td>WEWELER</td> </tr> </table>		US 86318F	WEWELER		
US 86318F	WEWELER						

I nominativi dei costruttori e i relativi riferimenti originali citati nel presente catalogo sono riportati a puro titolo indicativo. I nostri prodotti non sono originali ma con essi intercambiabili.
 The name of manufacturers and the o.e. references mentioned in this catalogue are given for cross-reference purposes only. Our products are not original but interchangeable with.



TIPO - TYPE	CODICE - CODE	RIFERIMENTO ORIGINALE - O. E. REFERENCE					
<p>C294/HS</p> <p>Pistone in composito <i>Composite piston</i></p>	<p>294.2.501</p>	<p>NEW</p> <table border="1" data-bbox="798 383 1525 439"> <tr> <td>-</td> <td>LECINENA TRAILER</td> </tr> <tr> <td>US06288F</td> <td>WEWELER</td> </tr> </table>		-	LECINENA TRAILER	US06288F	WEWELER
-	LECINENA TRAILER						
US06288F	WEWELER						
<p>C294/HS</p> <p>Pistone in composito <i>Composite piston</i></p>	<p>294.2.502</p>	<p>NEW</p> <table border="1" data-bbox="798 943 1525 972"> <tr> <td>US06287F</td> <td>WEWELER</td> </tr> </table>		US06287F	WEWELER		
US06287F	WEWELER						
<p>C294/R</p>	<p>294.0.461</p>	<p>NEW</p> <table border="1" data-bbox="798 1503 1525 1532"> <tr> <td>21229214</td> <td>ROR - MERITOR</td> </tr> </table>		21229214	ROR - MERITOR		
21229214	ROR - MERITOR						

I nominativi dei costruttori e i relativi riferimenti originali citati nel presente catalogo sono riportati a puro titolo indicativo. I nostri prodotti non sono originali ma con essi intercambiabili.
 The name of manufacturers and the o.e. references mentioned in this catalogue are given for cross-reference purposes only. Our products are not original but interchangeable with.

TIPO - TYPE	CODICE - CODE	RIFERIMENTO ORIGINALE - O. E. REFERENCE					
<p>C294/R</p> <p>Pistone in composito Composite piston</p>	<p>294.2.460</p>	<table border="1"> <tr> <td data-bbox="721 383 938 409">21229214</td> <td data-bbox="938 383 1444 409">ROR - MERITOR</td> </tr> </table>		21229214	ROR - MERITOR		
21229214	ROR - MERITOR						
<p>C294/S</p> <p>PISTONE IN COMPOSITO COMPOSITE PISTON</p>	<p>294.2.485</p>	<table border="1"> <tr> <td data-bbox="721 947 938 974">033ACC010001</td> <td data-bbox="938 947 1444 974">TECNOKAR</td> </tr> </table>		033ACC010001	TECNOKAR		
033ACC010001	TECNOKAR						
<p>C294/V</p>	<p>294.0.431</p>	<table border="1"> <tr> <td data-bbox="721 1512 938 1538">20456150</td> <td data-bbox="938 1512 1444 1538">VOLVO FM - FH</td> </tr> <tr> <td data-bbox="721 1538 938 1565">20427803</td> <td data-bbox="938 1538 1444 1565">VOLVO FM - FH</td> </tr> </table>		20456150	VOLVO FM - FH	20427803	VOLVO FM - FH
20456150	VOLVO FM - FH						
20427803	VOLVO FM - FH						

I nominativi dei costruttori e i relativi riferimenti originali citati nel presente catalogo sono riportati a puro titolo indicativo. I nostri prodotti non sono originali ma con essi intercambiabili.
 The name of manufacturers and the o.e. references mentioned in this catalogue are given for cross-reference purposes only. Our products are not original but interchangeable with.



TIPO - TYPE	CODICE - CODE	RIFERIMENTO ORIGINALE - O. E. REFERENCE														
<p>C294/V</p>	<p>294.1.430</p>	<table border="1"> <tr><td>1075890</td><td>VOLVO FM – FH</td></tr> <tr><td>20375226</td><td>VOLVO FM – FH</td></tr> <tr><td>20375227</td><td>VOLVO FM – FH</td></tr> <tr><td>20427800</td><td>VOLVO FM – FH</td></tr> <tr><td>20582206</td><td>VOLVO FM – FH</td></tr> <tr><td>20456150</td><td>VOLVO FM – FH</td></tr> <tr><td>20531984</td><td>VOLVO FM – FH</td></tr> </table>	1075890	VOLVO FM – FH	20375226	VOLVO FM – FH	20375227	VOLVO FM – FH	20427800	VOLVO FM – FH	20582206	VOLVO FM – FH	20456150	VOLVO FM – FH	20531984	VOLVO FM – FH
1075890	VOLVO FM – FH															
20375226	VOLVO FM – FH															
20375227	VOLVO FM – FH															
20427800	VOLVO FM – FH															
20582206	VOLVO FM – FH															
20456150	VOLVO FM – FH															
20531984	VOLVO FM – FH															
<p>C294/VA</p>	<p>294.1.370</p>	<table border="1"> <tr><td>70321694</td><td>VOLVO FH Posteriore / Rear</td></tr> <tr><td>3171694</td><td>VOLVO FH Posteriore / Rear</td></tr> <tr><td>20427804</td><td>VOLVO FM - FH Posteriore / Rear</td></tr> <tr><td>20427801</td><td>VOLVO FM - FH Posteriore / Rear</td></tr> <tr><td>20456154</td><td>VOLVO FM - FH Posteriore / Rear</td></tr> <tr><td>20531986</td><td>VOLVO FM - FH Posteriore / Rear</td></tr> <tr><td>20582209</td><td>VOLVO FM - FH Posteriore / Rear</td></tr> </table>	70321694	VOLVO FH Posteriore / Rear	3171694	VOLVO FH Posteriore / Rear	20427804	VOLVO FM - FH Posteriore / Rear	20427801	VOLVO FM - FH Posteriore / Rear	20456154	VOLVO FM - FH Posteriore / Rear	20531986	VOLVO FM - FH Posteriore / Rear	20582209	VOLVO FM - FH Posteriore / Rear
70321694	VOLVO FH Posteriore / Rear															
3171694	VOLVO FH Posteriore / Rear															
20427804	VOLVO FM - FH Posteriore / Rear															
20427801	VOLVO FM - FH Posteriore / Rear															
20456154	VOLVO FM - FH Posteriore / Rear															
20531986	VOLVO FM - FH Posteriore / Rear															
20582209	VOLVO FM - FH Posteriore / Rear															
<p>C295</p>	<p>295.2.510</p>	<table border="1"> <tr><td>431810</td><td>ACERBI</td></tr> <tr><td>42402006</td><td>BERTOJA</td></tr> <tr><td>2930530</td><td>GIRELLI</td></tr> <tr><td>112063</td><td>ROLFO</td></tr> <tr><td>128147104</td><td>VIBERTI</td></tr> <tr><td>1006555</td><td>ZORZI</td></tr> </table>	431810	ACERBI	42402006	BERTOJA	2930530	GIRELLI	112063	ROLFO	128147104	VIBERTI	1006555	ZORZI		
431810	ACERBI															
42402006	BERTOJA															
2930530	GIRELLI															
112063	ROLFO															
128147104	VIBERTI															
1006555	ZORZI															

I nominativi dei costruttori e i relativi riferimenti originali citati nel presente catalogo sono riportati a puro titolo indicativo. I nostri prodotti non sono originali ma con essi intercambiabili.
 The name of manufacturers and the o.e. references mentioned in this catalogue are given for cross-reference purposes only. Our products are not original but interchangeable with.

TIPO - TYPE	CODICE - CODE	RIFERIMENTO ORIGINALE - O. E. REFERENCE											
<p>C295</p>	<p>295.2.511</p>	<table border="1"> <tr> <td data-bbox="721 378 922 409">128147114</td> <td data-bbox="922 378 1445 409">VIBERTI</td> </tr> </table>		128147114	VIBERTI								
128147114	VIBERTI												
<p>C295</p>	<p>295.2.512</p>	<table border="1"> <tr> <td data-bbox="721 945 922 976">431811</td> <td data-bbox="922 945 1445 976">ACERBI</td> </tr> <tr> <td data-bbox="721 976 922 1008">431811</td> <td data-bbox="922 976 1445 1008">FRUEHAUF</td> </tr> </table>		431811	ACERBI	431811	FRUEHAUF						
431811	ACERBI												
431811	FRUEHAUF												
<p>C295/B</p>	<p>295.2.470</p>	<table border="1"> <tr> <td data-bbox="721 1505 922 1536">91619012</td> <td data-bbox="922 1505 1445 1536">BARTOLETTI</td> </tr> <tr> <td data-bbox="721 1536 922 1568">42402001</td> <td data-bbox="922 1536 1445 1568">BERTOJA</td> </tr> <tr> <td data-bbox="721 1568 922 1599">58050600</td> <td data-bbox="922 1568 1445 1599">CARDI</td> </tr> <tr> <td data-bbox="721 1599 922 1630">128147101</td> <td data-bbox="922 1599 1445 1630">VIBERTI</td> </tr> <tr> <td data-bbox="721 1630 922 1662">1006549</td> <td data-bbox="922 1630 1445 1662">ZORZI</td> </tr> </table>		91619012	BARTOLETTI	42402001	BERTOJA	58050600	CARDI	128147101	VIBERTI	1006549	ZORZI
91619012	BARTOLETTI												
42402001	BERTOJA												
58050600	CARDI												
128147101	VIBERTI												
1006549	ZORZI												

I nominativi dei costruttori e i relativi riferimenti originali citati nel presente catalogo sono riportati a puro titolo indicativo. I nostri prodotti non sono originali ma con essi intercambiabili.
 The name of manufacturers and the o.e. references mentioned in this catalogue are given for cross-reference purposes only. Our products are not original but interchangeable with.

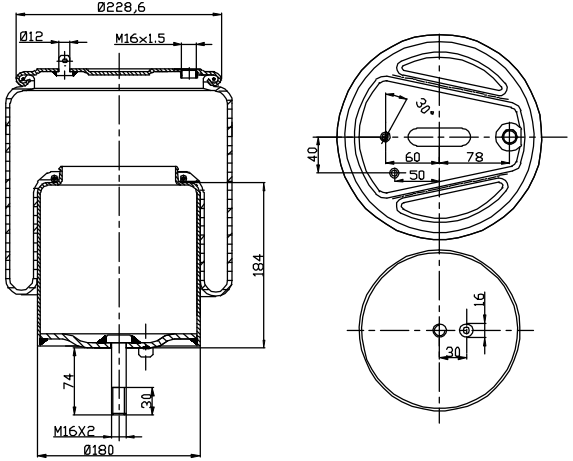
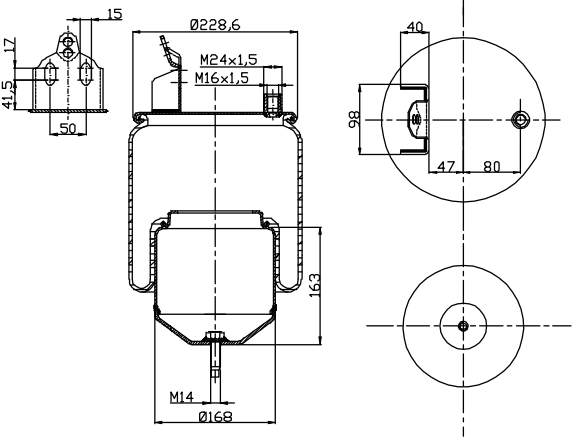
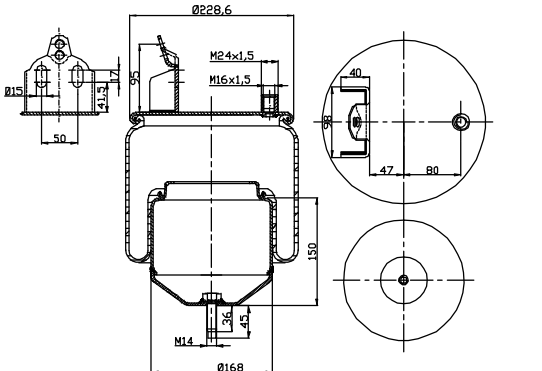

TIPO - TYPE	CODICE - CODE	RIFERIMENTO ORIGINALE - O. E. REFERENCE													
<p>C295/SC</p> 	<p>295.1.475</p>	<p>NEW</p> <table border="1" data-bbox="798 380 1516 414"> <tr> <td>1434930</td> <td>SCANIA V TRUCK</td> </tr> </table>		1434930	SCANIA V TRUCK										
1434930	SCANIA V TRUCK														
<p>C295/V</p> 	<p>295.1.465</p>	<table border="1" data-bbox="798 940 1516 1086"> <tr> <td>1076416</td> <td>VOLVO FM12 - FH12</td> </tr> <tr> <td>20374510</td> <td>VOLVO FM12 - FH12</td> </tr> <tr> <td>20531985</td> <td>VOLVO FM12 - FH12</td> </tr> <tr> <td>20582215</td> <td>VOLVO FM12 - FH12</td> </tr> <tr> <td>20456152</td> <td>VOLVO FM12 - FH12</td> </tr> </table>		1076416	VOLVO FM12 - FH12	20374510	VOLVO FM12 - FH12	20531985	VOLVO FM12 - FH12	20582215	VOLVO FM12 - FH12	20456152	VOLVO FM12 - FH12		
1076416	VOLVO FM12 - FH12														
20374510	VOLVO FM12 - FH12														
20531985	VOLVO FM12 - FH12														
20582215	VOLVO FM12 - FH12														
20456152	VOLVO FM12 - FH12														
<p>C295/VA</p> 	<p>295.1.400</p>	<table border="1" data-bbox="798 1500 1516 1668"> <tr> <td>20531987</td> <td>VOLVO FM-FH Posteriore / Rear</td> </tr> <tr> <td>20456156</td> <td>VOLVO FM-FH Posteriore / Rear</td> </tr> <tr> <td>20374511</td> <td>VOLVO FM-FH Posteriore / Rear</td> </tr> <tr> <td>3171695</td> <td>VOLVO FM-FH Posteriore / Rear</td> </tr> <tr> <td>1076418</td> <td>VOLVO FM-FH Posteriore / Rear</td> </tr> <tr> <td>20582214</td> <td>VOLVO FM - FH Posteriore / Rear</td> </tr> </table>		20531987	VOLVO FM-FH Posteriore / Rear	20456156	VOLVO FM-FH Posteriore / Rear	20374511	VOLVO FM-FH Posteriore / Rear	3171695	VOLVO FM-FH Posteriore / Rear	1076418	VOLVO FM-FH Posteriore / Rear	20582214	VOLVO FM - FH Posteriore / Rear
20531987	VOLVO FM-FH Posteriore / Rear														
20456156	VOLVO FM-FH Posteriore / Rear														
20374511	VOLVO FM-FH Posteriore / Rear														
3171695	VOLVO FM-FH Posteriore / Rear														
1076418	VOLVO FM-FH Posteriore / Rear														
20582214	VOLVO FM - FH Posteriore / Rear														

I nominativi dei costruttori e i relativi riferimenti originali citati nel presente catalogo sono riportati a puro titolo indicativo. I nostri prodotti non sono originali ma con essi intercambiabili.
 The name of manufacturers and the o.e. references mentioned in this catalogue are given for cross-reference purposes only. Our products are not original but interchangeable with.



TIPO - TYPE	CODICE - CODE	RIFERIMENTO ORIGINALE - O. E. REFERENCE	
<p>D296/D</p>	<p>296.1.340</p>		
		05101100	S.T. SYSTEM TRUCK
		03003000100	TRAS CAR
<p>D296/D</p>	<p>296.1.341</p>	NEW	
		CCA00199	B.B.M. BOLPAGNI
<p>D297/A</p>	<p>297.2.315</p>		488263 SCANIA BUS 94-114-124 Anteriore / Front
		1440303	SCANIA BUS 94-114-124 Anteriore / Front
		1475106	SCANIA BUS 94-114-124 Anteriore / Front
		1521114	SCANIA BUS 94-114-124 Anteriore / Front

I nominativi dei costruttori e i relativi riferimenti originali citati nel presente catalogo sono riportati a puro titolo indicativo. I nostri prodotti non sono originali ma con essi intercambiabili.
 The name of manufacturers and the o.e. references mentioned in this catalogue are given for cross-reference purposes only. Our products are not original but interchangeable with.



TIPO - TYPE	CODICE - CODE	RIFERIMENTO ORIGINALE - O. E. REFERENCE					
<p>D297/A</p>	<p>297.2.315/1</p>	<p>NEW</p> <table border="1" data-bbox="798 383 1525 439"> <tr> <td>1726239</td> <td>SCANIA</td> </tr> <tr> <td>1726257</td> <td>SCANIA</td> </tr> </table>		1726239	SCANIA	1726257	SCANIA
1726239	SCANIA						
1726257	SCANIA						
<p>D297/B</p>	<p>297.1.430</p>	<table border="1" data-bbox="798 943 1525 999"> <tr> <td>470922</td> <td>SCANIA BUS serie 4</td> </tr> <tr> <td>1440304</td> <td>SCANIA BUS serie 4</td> </tr> </table>		470922	SCANIA BUS serie 4	1440304	SCANIA BUS serie 4
470922	SCANIA BUS serie 4						
1440304	SCANIA BUS serie 4						
<p>D297/B</p>	<p>297.1.430/1</p>	<p>NEW</p> <table border="1" data-bbox="798 1503 1525 1536"> <tr> <td>1726240</td> <td>SCANIA</td> </tr> </table>		1726240	SCANIA		
1726240	SCANIA						

I nominativi dei costruttori e i relativi riferimenti originali citati nel presente catalogo sono riportati a puro titolo indicativo. I nostri prodotti non sono originali ma con essi intercambiabili.
 The name of manufacturers and the o.e. references mentioned in this catalogue are given for cross-reference purposes only. Our products are not original but interchangeable with.



TIPO - TYPE	CODICE - CODE	RIFERIMENTO ORIGINALE - O. E. REFERENCE	
<p>D297/B</p>	<p>297.1.431</p>		
		1834970	SCANIA BUS serie 4
		492680	SCANIA BUS 94-114-124
		1440305	SCANIA BUS 94-114-124
<p>D297/B</p>	<p>297.1.431/1</p>	NEW	
		1726241	SCANIA
<p>D297/B</p>	<p>297.1.432</p>		
		488264	SCANIA BUS 94-114-124
		1434506	SCANIA BUS 94-114-124

I nominativi dei costruttori e i relativi riferimenti originali citati nel presente catalogo sono riportati a puro titolo indicativo. I nostri prodotti non sono originali ma con essi intercambiabili.
 The name of manufacturers and the o.e. references mentioned in this catalogue are given for cross-reference purposes only. Our products are not original but interchangeable with.



TIPO - TYPE	CODICE - CODE	RIFERIMENTO ORIGINALE - O. E. REFERENCE				
<p>D297/B</p>	<p>297.1.432/1</p>	<p>NEW</p> <table border="1" data-bbox="798 380 1514 414"> <tr> <td>1726243</td> <td>SCANIA</td> </tr> </table>	1726243	SCANIA		
1726243	SCANIA					
<p>D297/C</p>	<p>297.1.300</p>	<table border="1" data-bbox="798 940 1514 996"> <tr> <td>1440307</td> <td>SCANIA BUS serie 4 Anteriore / Front</td> </tr> <tr> <td>475149</td> <td>SCANIA BUS serie 4 Anteriore / Front</td> </tr> </table>	1440307	SCANIA BUS serie 4 Anteriore / Front	475149	SCANIA BUS serie 4 Anteriore / Front
1440307	SCANIA BUS serie 4 Anteriore / Front					
475149	SCANIA BUS serie 4 Anteriore / Front					
<p>D297/C</p>	<p>297.1.300/1</p>	<p>NEW</p> <table border="1" data-bbox="798 1500 1514 1534"> <tr> <td>1726246</td> <td>SCANIA</td> </tr> </table>	1726246	SCANIA		
1726246	SCANIA					

I nominativi dei costruttori e i relativi riferimenti originali citati nel presente catalogo sono riportati a puro titolo indicativo. I nostri prodotti non sono originali ma con essi intercambiabili.
 The name of manufacturers and the o.e. references mentioned in this catalogue are given for cross-reference purposes only. Our products are not original but interchangeable with.

TIPO - TYPE	CODICE - CODE	RIFERIMENTO ORIGINALE - O. E. REFERENCE					
<p>C299/A</p>	<p>299.0.460</p>	<table border="1"> <tr> <td data-bbox="721 383 927 409">A9743280001</td> <td data-bbox="927 383 1444 409">MERCEDES ACTROS</td> </tr> </table>		A9743280001	MERCEDES ACTROS		
A9743280001	MERCEDES ACTROS						
<p>C299/A</p>	<p>299.0.461</p>	<table border="1"> <tr> <td data-bbox="721 947 927 974">A9423270001</td> <td data-bbox="927 947 1444 974">MERCEDES ACTROS</td> </tr> </table>		A9423270001	MERCEDES ACTROS		
A9423270001	MERCEDES ACTROS						
<p>C299/A</p>	<p>299.1.460</p>	<table border="1"> <tr> <td data-bbox="721 1512 927 1538">A9743204321</td> <td data-bbox="927 1512 1444 1538">MERCEDES ACTROS</td> </tr> <tr> <td data-bbox="721 1538 927 1565">A9743200417</td> <td data-bbox="927 1538 1444 1565">MERCEDES ACTROS</td> </tr> </table>		A9743204321	MERCEDES ACTROS	A9743200417	MERCEDES ACTROS
A9743204321	MERCEDES ACTROS						
A9743200417	MERCEDES ACTROS						

I nominativi dei costruttori e i relativi riferimenti originali citati nel presente catalogo sono riportati a puro titolo indicativo. I nostri prodotti non sono originali ma con essi intercambiabili.
 The name of manufacturers and the o.e. references mentioned in this catalogue are given for cross-reference purposes only. Our products are not original but interchangeable with.

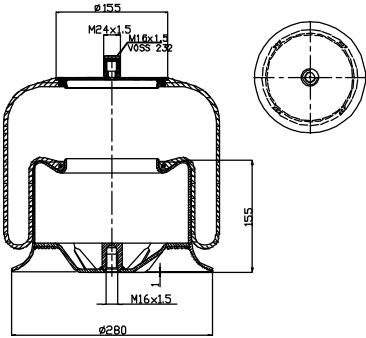
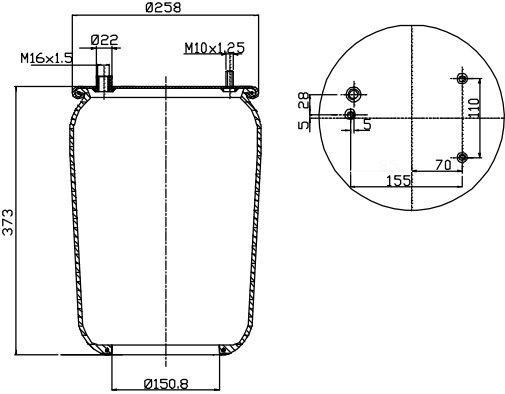
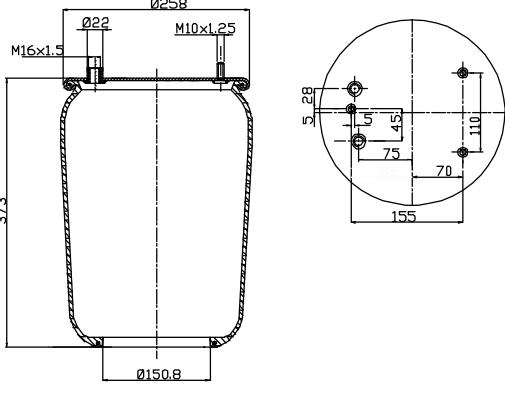

TIPO - TYPE	CODICE - CODE	RIFERIMENTO ORIGINALE - O. E. REFERENCE	
<p data-bbox="248 338 373 371">C299/A</p> 	<p data-bbox="555 338 711 371">299.1.461</p>	A9423203221	MERCEDES ACTROS
		A9423200107	MERCEDES ACTROS
		A9423200117	MERCEDES ACTROS
<p data-bbox="268 904 354 938">C302</p> 	<p data-bbox="555 904 711 938">302.0.376</p>	0067504	DAF
<p data-bbox="268 1464 354 1498">C302</p> 	<p data-bbox="555 1464 711 1498">302.0.376/2</p>	0513982	DAF

I nominativi dei costruttori e i relativi riferimenti originali citati nel presente catalogo sono riportati a puro titolo indicativo. I nostri prodotti non sono originali ma con essi intercambiabili.
 The name of manufacturers and the o.e. references mentioned in this catalogue are given for cross-reference purposes only. Our products are not original but interchangeable with.



TIPO - TYPE	CODICE - CODE	RIFERIMENTO ORIGINALE - O. E. REFERENCE	
<p>C302</p>	<p>302.1.375</p>	<p>388166</p>	<p>DAF</p>
		<p>388165</p>	<p>DAF</p>
<p>C302</p>	<p>302.1.375/2</p>	<p>388169</p>	<p>DAF</p>
		<p>388168</p>	<p>DAF</p>
		<p>388167</p>	<p>DAF</p>
<p>C302/B</p>	<p>302.0.521</p>	<p>81.43601.0155</p>	<p>MAN TGA</p>

I nominativi dei costruttori e i relativi riferimenti originali citati nel presente catalogo sono riportati a puro titolo indicativo. I nostri prodotti non sono originali ma con essi intercambiabili.
 The name of manufacturers and the o.e. references mentioned in this catalogue are given for cross-reference purposes only. Our products are not original but interchangeable with.

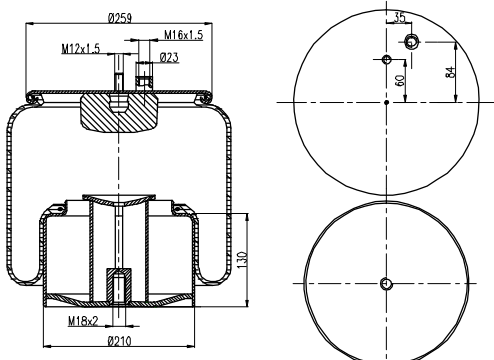
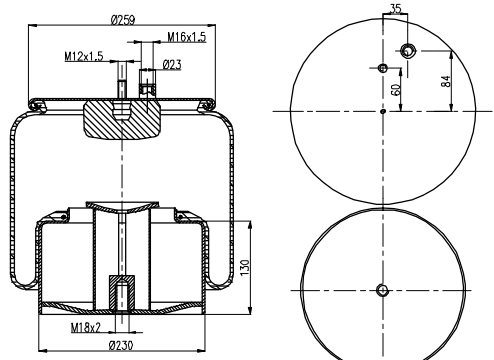
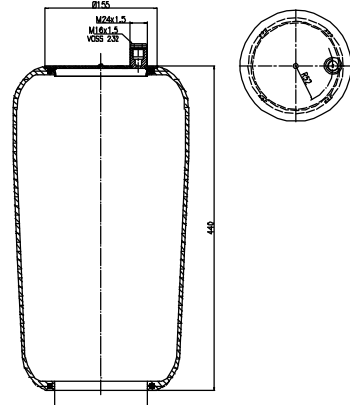

TIPO - TYPE	CODICE - CODE	RIFERIMENTO ORIGINALE - O. E. REFERENCE	
<p style="text-align: center;">C302/B</p> 	<p style="text-align: center;">302.1.520</p>	81.43600.6039	MAN TGA
<p style="text-align: center;">C302/B</p> 	<p style="text-align: center;">302.1.521</p>	81.43600.6040	MAN TGA
<p style="text-align: center;">C304</p> 	<p style="text-align: center;">304.0.440</p>	A942328001	MERCEDES ACTROS

I nominativi dei costruttori e i relativi riferimenti originali citati nel presente catalogo sono riportati a puro titolo indicativo. I nostri prodotti non sono originali ma con essi intercambiabili.
 The name of manufacturers and the o.e. references mentioned in this catalogue are given for cross-reference purposes only. Our products are not original but interchangeable with.

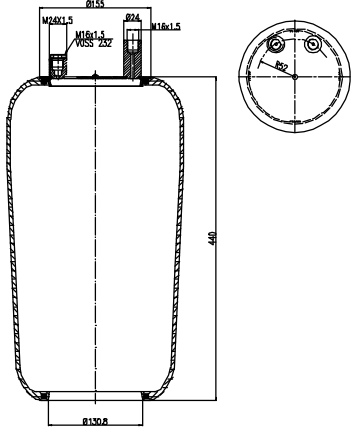
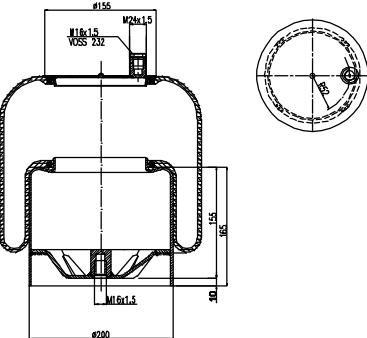
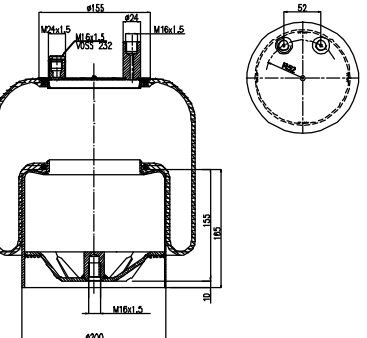

TIPO - TYPE	CODICE - CODE	RIFERIMENTO ORIGINALE - O. E. REFERENCE					
C304 	304.0.441	<table border="1"> <tr> <td data-bbox="726 383 927 409">A9423280101</td> <td data-bbox="927 383 1439 409">MERCEDES ACTROS</td> </tr> </table>		A9423280101	MERCEDES ACTROS		
A9423280101	MERCEDES ACTROS						
C304 	304.1.440	<table border="1"> <tr> <td data-bbox="726 947 927 974">A9423204921</td> <td data-bbox="927 947 1439 974">MERCEDES ACTROS</td> </tr> <tr> <td data-bbox="726 974 927 1001">A9423200121</td> <td data-bbox="927 974 1439 1001">MERCEDES ACTROS</td> </tr> </table>		A9423204921	MERCEDES ACTROS	A9423200121	MERCEDES ACTROS
A9423204921	MERCEDES ACTROS						
A9423200121	MERCEDES ACTROS						
C304 	304.1.441	<table border="1"> <tr> <td data-bbox="726 1507 927 1534">A9423205021</td> <td data-bbox="927 1507 1439 1534">MERCEDES ACTROS</td> </tr> <tr> <td data-bbox="726 1534 927 1561">A9423200221</td> <td data-bbox="927 1534 1439 1561">MERCEDES ACTROS</td> </tr> </table>		A9423205021	MERCEDES ACTROS	A9423200221	MERCEDES ACTROS
A9423205021	MERCEDES ACTROS						
A9423200221	MERCEDES ACTROS						

I nominativi dei costruttori e i relativi riferimenti originali citati nel presente catalogo sono riportati a puro titolo indicativo. I nostri prodotti non sono originali ma con essi intercambiabili.
 The name of manufacturers and the o.e. references mentioned in this catalogue are given for cross-reference purposes only. Our products are not original but interchangeable with.

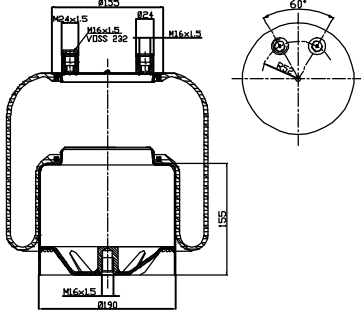
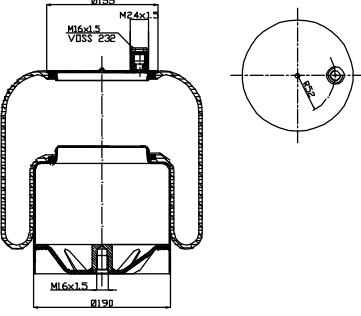
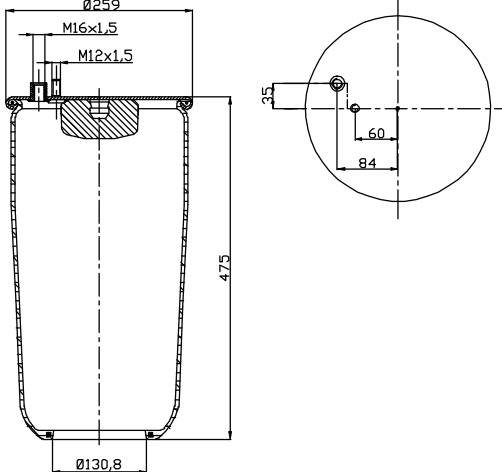

TIPO - TYPE	CODICE - CODE	RIFERIMENTO ORIGINALE - O. E. REFERENCE			
<p style="text-align: center;">C304</p> 	<p style="text-align: center;">304.1.443</p>	<table border="1" style="width: 100%; border-collapse: collapse;"> <tr> <td style="width: 50%; text-align: center;">A9423200421</td> <td style="width: 50%; text-align: center;">MERCEDES ACTROS</td> </tr> </table>		A9423200421	MERCEDES ACTROS
A9423200421	MERCEDES ACTROS				
<p style="text-align: center;">C304</p> 	<p style="text-align: center;">304.1.444</p>	<table border="1" style="width: 100%; border-collapse: collapse;"> <tr> <td style="width: 50%; text-align: center;">A9423200321</td> <td style="width: 50%; text-align: center;">MERCEDES ACTROS</td> </tr> </table>		A9423200321	MERCEDES ACTROS
A9423200321	MERCEDES ACTROS				
<p style="text-align: center;">C304/M3</p> 	<p style="text-align: center;">304.0.513</p>	<table border="1" style="width: 100%; border-collapse: collapse;"> <tr> <td style="width: 50%; text-align: center;">81.43601.0153</td> <td style="width: 50%; text-align: center;">MAN TGA</td> </tr> </table>		81.43601.0153	MAN TGA
81.43601.0153	MAN TGA				

I nominativi dei costruttori e i relativi riferimenti originali citati nel presente catalogo sono riportati a puro titolo indicativo. I nostri prodotti non sono originali ma con essi intercambiabili.
 The name of manufacturers and the o.e. references mentioned in this catalogue are given for cross-reference purposes only. Our products are not original but interchangeable with.



TIPO - TYPE	CODICE - CODE	RIFERIMENTO ORIGINALE - O. E. REFERENCE	
<p>C304/M3</p>	<p>304.1.513</p>	<p>81.43600.6037 MAN TGA</p>	
<p>C304/M4</p>	<p>304.0.511</p>	<p>81.43601.0152 MAN TGA</p>	
<p>C304/M4</p>	<p>304.1.510</p>	<p>81.43600.6035 MAN TGA</p>	

I nominativi dei costruttori e i relativi riferimenti originali citati nel presente catalogo sono riportati a puro titolo indicativo. I nostri prodotti non sono originali ma con essi intercambiabili.
 The name of manufacturers and the o.e. references mentioned in this catalogue are given for cross-reference purposes only. Our products are not original but interchangeable with.

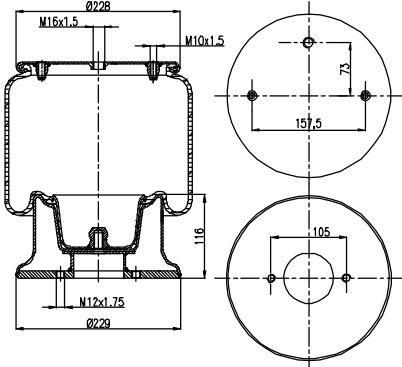
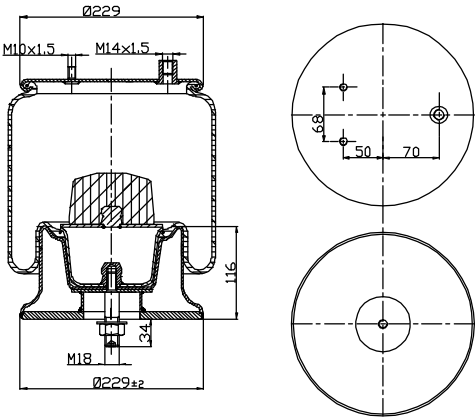
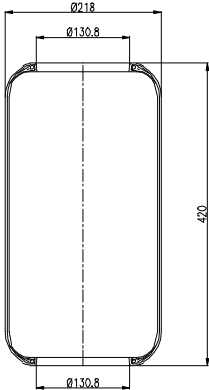

TIPO - TYPE	CODICE - CODE	RIFERIMENTO ORIGINALE - O. E. REFERENCE																								
<p>D306</p> 	<p>306.2.320</p>	<table border="1"> <tr><td>15619</td><td>GRANNING</td></tr> <tr><td>1402423</td><td>SCANIA serie 3-4-R (3° asse/3° axle)</td></tr> <tr><td>1394997</td><td>SCANIA serie 3-4-R (3° asse/3° axle)</td></tr> <tr><td>1314903</td><td>SCANIA serie 3-4-R (3° asse/3° axle)</td></tr> </table>	15619	GRANNING	1402423	SCANIA serie 3-4-R (3° asse/3° axle)	1394997	SCANIA serie 3-4-R (3° asse/3° axle)	1314903	SCANIA serie 3-4-R (3° asse/3° axle)																
15619	GRANNING																									
1402423	SCANIA serie 3-4-R (3° asse/3° axle)																									
1394997	SCANIA serie 3-4-R (3° asse/3° axle)																									
1314903	SCANIA serie 3-4-R (3° asse/3° axle)																									
<p>D306/A</p> 	<p>306.1.420</p>	<table border="1"> <tr><td>99458557</td><td>IVECO DX</td></tr> <tr><td>99458555</td><td>IVECO SX</td></tr> <tr><td>MO 557031</td><td>NEWAY</td></tr> <tr><td>MO 557030</td><td>NEWAY</td></tr> <tr><td>MO 557020</td><td>NEWAY DX</td></tr> <tr><td>MO 557019</td><td>NEWAY SX</td></tr> </table>	99458557	IVECO DX	99458555	IVECO SX	MO 557031	NEWAY	MO 557030	NEWAY	MO 557020	NEWAY DX	MO 557019	NEWAY SX												
99458557	IVECO DX																									
99458555	IVECO SX																									
MO 557031	NEWAY																									
MO 557030	NEWAY																									
MO 557020	NEWAY DX																									
MO 557019	NEWAY SX																									
<p>D276</p> 	<p>276.0.420</p>	<table border="1"> <tr><td>46311005</td><td>BERTOJA</td></tr> <tr><td>178741</td><td>BREDAMENARINIBUS</td></tr> <tr><td>650292/8</td><td>DENNIS</td></tr> <tr><td>4716989</td><td>FIAT</td></tr> <tr><td>-</td><td>IVECO</td></tr> <tr><td>4716989</td><td>IVECO</td></tr> <tr><td>-</td><td>IVECO-PEGASO</td></tr> <tr><td>3823277201</td><td>MERCEDES</td></tr> <tr><td>5000954176</td><td>RVI</td></tr> <tr><td>5000869179</td><td>RVI</td></tr> <tr><td>5000787632</td><td>RVI</td></tr> <tr><td>-</td><td>SCANIA</td></tr> </table>	46311005	BERTOJA	178741	BREDAMENARINIBUS	650292/8	DENNIS	4716989	FIAT	-	IVECO	4716989	IVECO	-	IVECO-PEGASO	3823277201	MERCEDES	5000954176	RVI	5000869179	RVI	5000787632	RVI	-	SCANIA
46311005	BERTOJA																									
178741	BREDAMENARINIBUS																									
650292/8	DENNIS																									
4716989	FIAT																									
-	IVECO																									
4716989	IVECO																									
-	IVECO-PEGASO																									
3823277201	MERCEDES																									
5000954176	RVI																									
5000869179	RVI																									
5000787632	RVI																									
-	SCANIA																									

I nominativi dei costruttori e i relativi riferimenti originali citati nel presente catalogo sono riportati a puro titolo indicativo. I nostri prodotti non sono originali ma con essi intercambiabili.
 The name of manufacturers and the o.e. references mentioned in this catalogue are given for cross-reference purposes only. Our products are not original but interchangeable with.



TIPO - TYPE	CODICE - CODE	RIFERIMENTO ORIGINALE - O. E. REFERENCE
-------------	---------------	---

D276/B	276.0.390
---------------	------------------

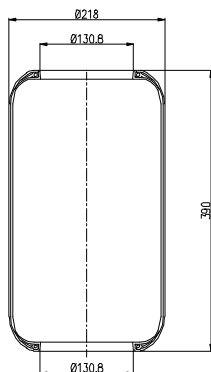

02.200.24.40.0	B.P.W.
199196	BREDAMENARINIBUS
536905265	BUSSING
536905266	BUSSING
644425	DAF
689677	DAF
696229	DAF
-	DROGMOELLER
546905134	HANOMAG HENSCHEL
0305G	HEULIEZ
303	HEULIEZ
-	IKARUS
4771441000	KAESSBOHRER
4771359000	KAESSBOHRER
4771170000	KAESSBOHRER
4771143000	KAESSBOHRER
4771110000	KAESSBOHRER
81.43601.0017	MAN
3643277001	MERCEDES
3073270001	MERCEDES
3073270101	MERCEDES
A0003270101	MERCEDES
3273280001	MERCEDES
3073280001	MERCEDES
1001-103-00	NEOPLAN
1001-122-54	NEOPLAN
1590136	SETRA
4771441000	SETRA
624319-630	VAN HOOL
624319-610	VAN HOOL
624319-600	VAN HOOL
624319-420	VAN HOOL
1134445	VOLVO
1199873	VOLVO
1590136	VOLVO
1622111	VOLVO
3159252	VOLVO
1199893	VOLVO

I nominativi dei costruttori e i relativi riferimenti originali citati nel presente catalogo sono riportati a puro titolo indicativo. I nostri prodotti non sono originali ma con essi intercambiabili.
 The name of manufacturers and the o.e. references mentioned in this catalogue are given for cross-reference purposes only. Our products are not original but interchangeable with.



TIPO - TYPE	CODICE - CODE	RIFERIMENTO ORIGINALE - O. E. REFERENCE	
D276/BS	276.0.391		
		99459166	IVECO
		5010151379	RVI
		5010151378	RVI
		5000288982	RVI
D276/C	276.0.370		
		325993	BREDAMENARINIBUS
		178623	BREDAMENARINIBUS
		TO01857	CACCIAMALI
		627584	DAF
		4840001	INBUS
		5001098	INBUS
		4890001	INBUS
		4840005	INBUS
		4714019	IVECO
		4714025	IVECO
		4722525	IVECO
		4735768	IVECO
		4738008	IVECO
		TO01857	IVECO
		6657150	IVECO
		4736728	IVECO
		2491566	MAGIRUS DEUTZ
		3373270001	MERCEDES
		3833270001	MERCEDES
		A3833270001	MERCEDES
		700176	PORTESI
		4840005	SICCA
		624319-860	VAN HOOL
		1611776	VOLVO

I nominativi dei costruttori e i relativi riferimenti originali citati nel presente catalogo sono riportati a puro titolo indicativo. I nostri prodotti non sono originali ma con essi intercambiabili.
 The name of manufacturers and the o.e. references mentioned in this catalogue are given for cross-reference purposes only. Our products are not original but interchangeable with.

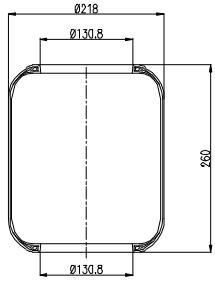
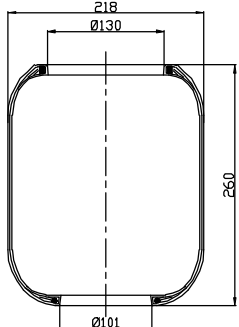
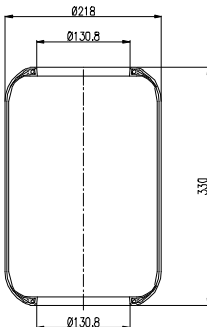

TIPO - TYPE	CODICE - CODE	RIFERIMENTO ORIGINALE - O. E. REFERENCE	
D276/D	276.0.260	S5001051	BREDAMENARINIBUS
		199563	IVECO
			
D276/DS	276.0.262	NEW	
		8160165	IVECO Eurotech MP400E
			
D276/E	276.0.330	577443	CARROZZERIA AUTODROMO DI MODENA
		4843220	IVECO
			

I nominativi dei costruttori e i relativi riferimenti originali citati nel presente catalogo sono riportati a puro titolo indicativo. I nostri prodotti non sono originali ma con essi intercambiabili.
 The name of manufacturers and the o.e. references mentioned in this catalogue are given for cross-reference purposes only. Our products are not original but interchangeable with.



TIPO - TYPE	CODICE - CODE	RIFERIMENTO ORIGINALE - O. E. REFERENCE
D276/F	276.0.300	41008929 IVECO EUROTECH
D276/FS	276.0.301	NEW 5001051 INBUS 150-210-240-2001
D276/L	276.0.480	- AUSTERAS - CAR VENETA (fino al 09/92) - TRAS CAR

I nominativi dei costruttori e i relativi riferimenti originali citati nel presente catalogo sono riportati a puro titolo indicativo. I nostri prodotti non sono originali ma con essi intercambiabili.
 The name of manufacturers and the o.e. references mentioned in this catalogue are given for cross-reference purposes only. Our products are not original but interchangeable with.



TIPO - TYPE	CODICE - CODE	RIFERIMENTO ORIGINALE - O. E. REFERENCE	
D278	278.0.430		
		58050315	CARDI
		-	FIAT
		795097	IVECO-PEGASO
		794686	IVECO-PEGASO
		412418	SCANIA
		411623	SCANIA
		411622	SCANIA
		402315	SCANIA
D278/B	278.0.355		
		91644001	BARTOLETTI
		178739	BREDAMENARINIBUS
D278/C	278.0.270		
		85001098	BREDAMENARINIBUS
		5001964	INBUS

I nominativi dei costruttori e i relativi riferimenti originali citati nel presente catalogo sono riportati a puro titolo indicativo. I nostri prodotti non sono originali ma con essi intercambiabili.
 The name of manufacturers and the o.e. references mentioned in this catalogue are given for cross-reference purposes only. Our products are not original but interchangeable with.



TIPO - TYPE	CODICE - CODE	RIFERIMENTO ORIGINALE - O. E. REFERENCE	
D286	286.0.420		
		500324098	IVECO BUS 491 Cityclass (Anteriore / Front)
D286/B	286.0.550		
		500364663	IVECO EUROTECH
C289	289.0.350		
		8166050	IVECO
		98411807	IVECO

I nominativi dei costruttori e i relativi riferimenti originali citati nel presente catalogo sono riportati a puro titolo indicativo. I nostri prodotti non sono originali ma con essi intercambiabili.
 The name of manufacturers and the o.e. references mentioned in this catalogue are given for cross-reference purposes only. Our products are not original but interchangeable with.



TIPO - TYPE	CODICE - CODE	RIFERIMENTO ORIGINALE - O. E. REFERENCE	
C289/B	289.0.300		
		8137291	IVECO
C289/BS	289.0.301		
		252933	BREDAMENARINIBUS
C289/C	289.0.450		
		42534924	IVECO
		98478799	IVECO
		81.43601.0123	MAN
		81.43601.0140	MAN
		81.43601.0125	MAN
		81.43601.0150	MAN
		81.43601.0120	MAN
		81.43601.0111	MAN
		81.43601.0109	MAN
		81.43601.0104	MAN
3633280201	MERCEDES		

I nominativi dei costruttori e i relativi riferimenti originali citati nel presente catalogo sono riportati a puro titolo indicativo. I nostri prodotti non sono originali ma con essi intercambiabili.
 The name of manufacturers and the o.e. references mentioned in this catalogue are given for cross-reference purposes only. Our products are not original but interchangeable with.



TIPO - TYPE	CODICE - CODE	RIFERIMENTO ORIGINALE - O. E. REFERENCE	
C289/C1	289.0.455	NEW	
	81.43601.0126	MAN BUS	
	81.43601.0100	MAN BUS	
	81.43601.0105	MAN BUS	
	81.43601.0102	MAN BUS	
	81.43601.0097	MAN BUS	
	81.43601.0095	MAN BUS	
C289/D	289.0.400		
	81.43601.0132	MAN	
	81.43601.0121	MAN	
	81.43601.0103	MAN	
	81.43601.0100	MAN	
	81.43601.0099	MAN	
	81.43601.0097	MAN	
	81.43601.0095	MAN	
	81.43601.0094	MAN	
	81.43601.0093	MAN	
	81.43601.0092	MAN	
	81.43601.0070	MAN	
81.43601.0032	MAN		
C289/E	289.0.360		
	5.001.843.640	IRISBUS	

I nominativi dei costruttori e i relativi riferimenti originali citati nel presente catalogo sono riportati a puro titolo indicativo. I nostri prodotti non sono originali ma con essi intercambiabili.
 The name of manufacturers and the o.e. references mentioned in this catalogue are given for cross-reference purposes only. Our products are not original but interchangeable with.



TIPO - TYPE	CODICE - CODE	RIFERIMENTO ORIGINALE - O. E. REFERENCE	
C289/G	289.0.460	NEW	
		5.001.857.612	IRISBUS
		5001531180	IVECO
		504157038	IVECO
		5001857612	IVECO
D290	290.0.420		
		8188539	IVECO
		81.43601.0108	MAN
		81.43601.0106	MAN
		81.43601.0069	MAN
		81.43601.0068	MAN
		81.43601.0066	MAN
		A6583280001	MERCEDES
	5010294385	RV1	
D290/B	290.0.390		
		8188526	IVECO
		523229	SCANIA

I nominativi dei costruttori e i relativi riferimenti originali citati nel presente catalogo sono riportati a puro titolo indicativo. I nostri prodotti non sono originali ma con essi intercambiabili.
 The name of manufacturers and the o.e. references mentioned in this catalogue are given for cross-reference purposes only. Our products are not original but interchangeable with.



TIPO - TYPE	CODICE - CODE	RIFERIMENTO ORIGINALE - O. E. REFERENCE	
D290/C	290.0.440		
		500364686	IVECO EUROTECH - EUROSTAR
D290/D	290.0.480		
		500319479	IVECO EUROTECH - EUROSTAR - STRALIS
D290/E	290.0.340		
		D020990	BREDAMENARINIBUS
		20990	BREDAMENARINIBUS
		42531994	IVECO

I nominativi dei costruttori e i relativi riferimenti originali citati nel presente catalogo sono riportati a puro titolo indicativo. I nostri prodotti non sono originali ma con essi intercambiabili.
 The name of manufacturers and the o.e. references mentioned in this catalogue are given for cross-reference purposes only. Our products are not original but interchangeable with.



TIPO - TYPE	CODICE - CODE	RIFERIMENTO ORIGINALE - O. E. REFERENCE	
D290/F	290.0.555	NEW	
	500341494		IVECO Eurotech - Eurostar
C292/C	292.0.380		
	02.200.24.60.0		B.P.W.
	683392		DAF
578361		DAF	
659561		DAF	
268 0662 000		FRUEHAUF	
4763473		IVECO	
42536242		IVECO	
81.43601.0051		MAN	
90.83112.0018		MAN	
81.43601.0060		MAN	
81.43601.0061		MAN	
81.43601.0117		MAN	
81.43601.0081		MAN	
81.43601.0083		MAN	
81.43601.0059		MAN	
81.43601.0090		MAN	
81.43601.0113		MAN	
81.43601.0115		MAN	
81.43601.0078		MAN	
A3632290001		MERCEDES	
3633280001		MERCEDES	
AA 10-01-002		NEOPLAN	
1001 102 00		NEOPLAN	
1001 122 51		NEOPLAN	
5000786901		RVI	
5000819517		RVI	
750 209		SCHMITZ	
3422596		VAN HOOL	
6885533		VOLVO	

I nominativi dei costruttori e i relativi riferimenti originali citati nel presente catalogo sono riportati a puro titolo indicativo. I nostri prodotti non sono originali ma con essi intercambiabili.
 The name of manufacturers and the o.e. references mentioned in this catalogue are given for cross-reference purposes only. Our products are not original but interchangeable with.



TIPO - TYPE	CODICE - CODE	RIFERIMENTO ORIGINALE - O. E. REFERENCE	
C292/D	292.0.450		
		638148	DAF
		166226	GIGANT
		196043	GIGANT
		4731013000	KAESSBOHRER
		81.43601.0118	MAN
		81.43601.0056	MAN
		81.43601.0057	MAN
		81.43601.0058	MAN
		81.43601.0076	MAN
		81.43601.0079	MAN
		81.43601.0082	MAN
		81.43601.0084	MAN
		81.43601.0091	MAN
		81.43601.0116	MAN
		81.43601.0114	MAN
		3073280101	MERCEDES
		90557023	NEWAY
		750212	SCHMITZ
		624319-614	VAN HOOL
		624319-640	VAN HOOL
	1134446	VOLVO	
C292/E	292.0.520		
		05.429.39.73.0	B.P.W.
		05.429.39.640	B.P.W.
		02.2002.4000	B.P.W.
		-	BERTOJA
		818225	DAF
		196036	GIGANT
		166205	GIGANT
		4731032000	KAESSBOHRER
		1021-002-00	NEOPLAN
		1001-101-00	NEOPLAN
		112269	ROLFO BISARCA
		750215	SCHMITZ

I nominativi dei costruttori e i relativi riferimenti originali citati nel presente catalogo sono riportati a puro titolo indicativo. I nostri prodotti non sono originali ma con essi intercambiabili.
 The name of manufacturers and the o.e. references mentioned in this catalogue are given for cross-reference purposes only. Our products are not original but interchangeable with.

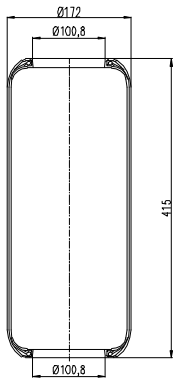
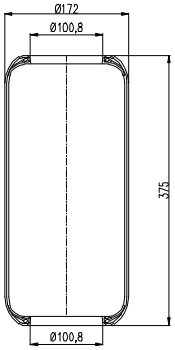
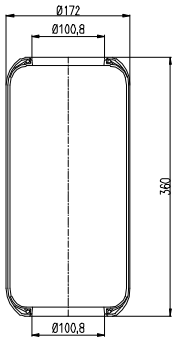

TIPO - TYPE	CODICE - CODE	RIFERIMENTO ORIGINALE - O. E. REFERENCE	
D296 	296.0.415	42530279 IVECO	
D296/B 	296.0.375	42807 BREDAMENARINIBUS	
D296/C 	296.0.360	500301776 IVECO	

I nominativi dei costruttori e i relativi riferimenti originali citati nel presente catalogo sono riportati a puro titolo indicativo. I nostri prodotti non sono originali ma con essi intercambiabili.
 The name of manufacturers and the o.e. references mentioned in this catalogue are given for cross-reference purposes only. Our products are not original but interchangeable with.



TIPO - TYPE	CODICE - CODE	RIFERIMENTO ORIGINALE - O. E. REFERENCE	
D296/D	296.0.340		
		192709	BREDAMENARINIBUS
		577472	CARROZZERIA AUTODROMO DI MODENA
		98445471	IVECO
D297	297.0.390		
		831120144	BUSSING
		440320200002-00	DROGMOELLER
		536905266	HANOMAG HENSCHEL
		536905265	HANOMAG HENSCHEL
		4182227	IVECO
		4746733	IVECO
		93197594	IVECO
		4731012000	KAESSBOHRER
		4731031000	KAESSBOHRER
		4771427000	KAESSBOHRER
		4771440000	KAESSBOHRER
		4731010000	KAESSBOHRER
		41822247	MAGIRUS DEUTZ
		249.8667 EC506704	MAGIRUS DEUTZ
		2498667	MAGIRUS DEUTZ
		90.83112.0144	MAN
		M 10-01-001	NEOPLAN
		1001-122-50	NEOPLAN
		5001829866	RVI
		750208	SCHMITZ
624319-690	VAN HOOL		
624319-670	VAN HOOL		
624319-700	VAN HOOL		
3159253	VOLVO		
1593842	VOLVO		
1137888	VOLVO		
1137882	VOLVO		

I nominativi dei costruttori e i relativi riferimenti originali citati nel presente catalogo sono riportati a puro titolo indicativo. I nostri prodotti non sono originali ma con essi intercambiabili.
 The name of manufacturers and the o.e. references mentioned in this catalogue are given for cross-reference purposes only. Our products are not original but interchangeable with.

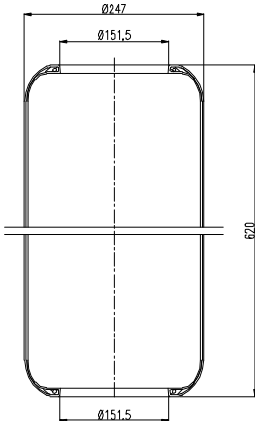
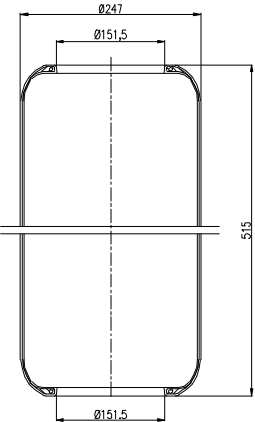
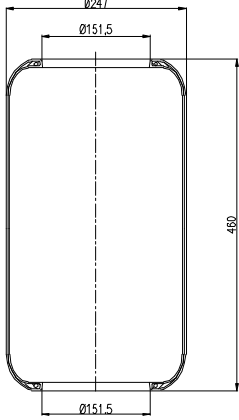

TIPO - TYPE	CODICE - CODE	RIFERIMENTO ORIGINALE - O. E. REFERENCE	
D298 	298.0.620	500310931 IVECO	
D298/B 	298.0.515	41022620 IVECO	
D298/C 	298.0.460	8139068 IVECO	

I nominativi dei costruttori e i relativi riferimenti originali citati nel presente catalogo sono riportati a puro titolo indicativo. I nostri prodotti non sono originali ma con essi intercambiabili.
 The name of manufacturers and the o.e. references mentioned in this catalogue are given for cross-reference purposes only. Our products are not original but interchangeable with.



TIPO - TYPE	CODICE - CODE	RIFERIMENTO ORIGINALE - O. E. REFERENCE	
D298/D	298.0.385		
		4847671	IVECO
		4843255	IVECO
		4212432	IVECO
D298/E	298.0.355		
		4746740	IVECO
		4456111	IVECO
		A3933280101	MERCEDES
C299	299.0.450		
		02.200.24.10.0	B.P.W.
		650883	DENNIS
		650884	DENNIS
		650292	DENNIS
		81.43601.0036	MAN
		81.43601.0033	MAN
		81.43601.0037	MAN
		81.43601.0126	MAN
		A3073280101	MERCEDES
		3873280001	MERCEDES
		A3603280101	MERCEDES
		A3633280101	MERCEDES
		3873280101	MERCEDES
		X 6641056	METRO CAMEL WEYMANN
		1001-123-00	NEOPLAN
1629193	VOLVO		
1622115	VOLVO		
1590136	VOLVO		

I nominativi dei costruttori e i relativi riferimenti originali citati nel presente catalogo sono riportati a puro titolo indicativo. I nostri prodotti non sono originali ma con essi intercambiabili.
 The name of manufacturers and the o.e. references mentioned in this catalogue are given for cross-reference purposes only. Our products are not original but interchangeable with.



TIPO - TYPE	CODICE - CODE	RIFERIMENTO ORIGINALE - O. E. REFERENCE	
C299/E	299.0.490		
		2680421000	VOLVO
		1622115	VOLVO
		1075290	VOLVO
C301	301.0.330		
		97108363	IVECO
		81.43601.0128	MAN
		81.43601.0110	MAN
		81.43601.0072	MAN
		81.43601.0071	MAN
		1082085	VOLVO
C301/B	301.0.235		
		41006926	IVECO

I nominativi dei costruttori e i relativi riferimenti originali citati nel presente catalogo sono riportati a puro titolo indicativo. I nostri prodotti non sono originali ma con essi intercambiabili.
 The name of manufacturers and the o.e. references mentioned in this catalogue are given for cross-reference purposes only. Our products are not original but interchangeable with.

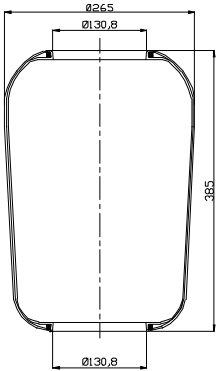
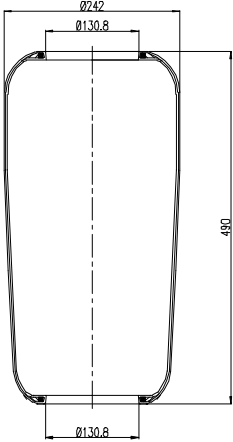
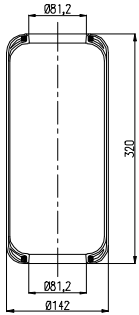

TIPO - TYPE	CODICE - CODE	RIFERIMENTO ORIGINALE - O. E. REFERENCE	
C302/A 	302.0.385	5.000.954.176	RVI
		5.000.954.175	RVI
		5.000.869.135	RVI
		5.000.786.516	RVI
		1612455	VOLVO
		1612465	VOLVO
		C304/B 	304.0.490
		1622116	VOLVO
D305 	305.0.320		

I nominativi dei costruttori e i relativi riferimenti originali citati nel presente catalogo sono riportati a puro titolo indicativo. I nostri prodotti non sono originali ma con essi intercambiabili.
 The name of manufacturers and the o.e. references mentioned in this catalogue are given for cross-reference purposes only. Our products are not original but interchangeable with.



TABELLA COMPARATIVA MOLLE AD ARIA da codice original AIR SPRINGS CROSS-REFERENCE LIST from O.E code

Cod. originale O.E. code	Cod. GART GART code	Cod. originale O.E. code	Cod. GART GART code	Cod. originale O.E. code	Cod. GART GART code
ACERBI		99381059	291.2.200	05.429.40.09.1	293.2.512
431810	295.2.510	B.B.M. BOLPAGNI		05.429.40.14.1	292.2.530
431811	295.2.512	CCA00199	296.1.341	05.429.40.28.1	293.2.510
448543	277.4.507	CCA00200	278.2.340	05.429.40.37.1	293.2.512
448543	277.4.500	B.P.W.		05.429.40.39.1	292.2.530
UJB 0203-001	278.2.511	0.40.19.000.0	275.1.180	05.429.40.44.0	292.0.601
ADIGE		0.41.03.003.0	277.4.520	05.429.40.47.1	292.2.530
03001537	292.2.460/1	0.41.03.007.0	278.4.512	05.429.40.52.1	293.2.510
10902700	271.2.200	0.41.03.009.0	277.4.521	05.429.40.58.0	292.0.601
ASSALI STEFEN		0.41.03.013.0	277.4.504	05.429.40.59.1	293.2.512
M19141000	275.1.120	0.41.03.015.0	276.1.371	05.429.40.59.1	293.2.510
AUSTERAS		0.41.03.016.0	277.4.523	05.429.40.61.1	292.2.530
98381037	282.2.533	0.41.03.019.0	277.4.524	05.429.40.72.0	293.0.611
99381001	275.1.120	0.41.04.001.0	278.2.430	05.429.40.75.0	293.0.611
99381002	281.2.190	0.41.04.003.0	271.3.290	05.429.40.91.0	293.0.411
99381003	271.3.290	0.41.04.004.0	274.2.210	05.429.41.01.0	292.0.461
99381007	274.2.270	0.41.04.005.0	277.4.501	05.429.41.21.1	292.2.530
99381009	276.1.420	01.429.40.28.1	293.0.511	05.429.41.21.1	292.2.532
99381010	276.1.480	02.200.20.80.0	272.0.199	05.429.41.22.1	292.2.460
99381014	279.2.174	02.200.21.90.0	271.2.200	05.429.41.24.1	293.0.511
99381015	274.2.310	02.200.24.10.0	299.0.450	05.429.41.24.1	293.2.510
99381019	271.2.252	02.200.24.40.0	276.0.390	05.429.41.24.1	293.2.512
99381022	278.4.422	02.200.24.60.0	292.0.380	05.429.41.25.0	293.0.513
99381024	274.2.210	02.2002.4000	292.0.520	05.429.41.28.0	293.2.512
99381027	276.1.486	04.429.40.76.0	293.0.611	05.429.41.28.1	293.2.510
99381027	276.1.487	05.429.39.640	292.0.520	05.429.41.36.1	292.2.532
99381031	278.2.520	05.429.39.73.0	292.0.520	05.429.41.36.1	292.2.530
99381032	276.1.482	05.429.40.01.0	292.0.531	05.429.41.37.1	293.2.510
99381035	271.2.253	05.429.40.02.0	292.0.531	05.429.41.37.1	293.2.512
99381036	277.4.420	05.429.40.03.0	293.0.511	05.429.41.38.0	292.0.601
99381041	271.3.296	05.429.40.05.0	292.0.601	05.429.41.56.0	293.0.413
99381047	282.2.537	05.429.40.08.1	292.2.530	05.429.41.69.0	292.0.601
99381050.1	277.4.425/1	05.429.40.08.1	292.2.532	05.429.41.77.0	293.0.412
		05.429.40.09.1	293.2.510	05.429.42.03.0	293.0.514

I nominativi dei costruttori e i relativi riferimenti originali citati nel presente catalogo sono riportati a puro titolo indicativo. I nostri prodotti non sono originali ma con essi intercambiabili.
The name of manufacturers and the o.e. references mentioned in this catalogue are given for cross-reference purposes only. Our products are not original but interchangeable with.



TABELLA COMPARATIVA MOLLE AD ARIA da codice original AIR SPRINGS CROSS-REFERENCE LIST from O.E code

Cod. originale O.E. code	Cod. GART GART code	Cod. originale O.E. code	Cod. GART GART code	Cod. originale O.E. code	Cod. GART GART code		
05.429.42.04.0	293.0.414	22.114.00	287.4.521	BUSSING			
05.429.42.41.1	293.2.410	22.114.03	277.2.420				
05.429.42.54.0	293.2.514	22.114.07	274.2.310				
05.429.43.20.0	293.2.512	22.114.09	282.2.530				
05.429.43.21.0	293.2.412	22.119.00	276.2.421				
05.429.43.23.0	293.2.414	22.119.07	276.1.421				
05.429.43.26.0	293.2.415	BELLE TRAILERS					
05.429.43.29.0	293.2.513	BT0319	278.2.422				
05.429.43.34.0	293.2.512	BERTOJA					
05.429.43.41.0	292.2.462	42402001	295.2.470			CACCIAMALI	
05.429.43.45.0	292.2.602	42402003	277.4.500				
05.429.43.51.0	292.2.532	42402003	277.4.507				
05.429.43.52.0	293.2.612	42402006	295.2.510				
05.429.43.56.0	293.2.512	45402002	277.4.420	CAMPANA			
05.429.43.62.0	293.2.514	45402004	278.2.422				
05.801.09.73.0	293.2.512	45402007	278.2.512				
05.801.09.74.0	293.2.412	46311001	277.2.421				
05.801.21.28.0	292.2.462	46311005	276.0.420				
05.801.21.29.0	292.2.462	46311033	292.2.602				
05.801.21.31.0	292.2.532	BREDAMENARINIBUS					
05.801.21.32.0	292.2.532	178623	276.0.370				
BARTOLETTI		178739	278.0.355			CARDI	
4823115	278.2.422	178741	276.0.420				
91619005	287.2.510	192709	296.0.340				
91619007	277.4.420	199196	276.0.390				
91619012	295.2.470	20990	290.0.340				
91621022	271.2.200	252933	289.0.301				
91621110	275.1.120	325993	276.0.370				
91621322	271.3.293	42807	296.0.375				
91644001	278.0.355	831120120	271.2.200				
BATTAGLINO		85001098	278.0.270	CAMPANA			
22.068.00	274.2.270	D020990	290.0.340				
22.070.00	275.1.120	S5001051	276.0.260				
22.070.05	275.1.170						
						CARDI	

I nominativi dei costruttori e i relativi riferimenti originali citati nel presente catalogo sono riportati a puro titolo indicativo. I nostri prodotti non sono originali ma con essi intercambiabili.
The name of manufacturers and the o.e. references mentioned in this catalogue are given for cross-reference purposes only. Our products are not original but interchangeable with.



TABELLA COMPARATIVA MOLLE AD ARIA da codice original AIR SPRINGS CROSS-REFERENCE LIST from O.E code

Cod. originale O.E. code	Cod. GART GART code	Cod. originale O.E. code	Cod. GART GART code	Cod. originale O.E. code	Cod. GART GART code
CARROZZERIA AUTODROMO DI		ERF		166252	292.0.533
577443	276.0.330	143908-3	277.4.507	196028	281.2.190
577472	296.0.340	143908-3	277.4.500	196036	292.0.520
DAF		FIAT		196043	292.0.450
0067504	302.0.376	4716989	276.0.420	GIRELLI	
0513982	302.0.376/2	FREIGHTLINER		012220530	278.2.422
388165	302.1.375	1613810000	278.0.434	20.38.0002.0	278.2.439
388166	302.1.375	1613810000	278.1.430	20.38.1500.0	271.3.295
388167	302.1.375/2	6813200017	278.1.430	2930530	295.2.510
388168	302.1.375/2	6813200017	278.0.434	590530	271.2.200
388169	302.1.375/2	FRUEHAUF		GRANNING	
388491	277.4.500	003615E	277.4.507	1359	278.2.422
388491	277.4.507	003615E	277.4.500	1371	291.2.200
526823	277.4.506	1525199	278.1.510	1528	278.2.422
578361	292.0.380	268 0662 000	292.0.380	15599	291.2.203
627584	276.0.370	431811	295.2.512	15603	291.2.200
638148	292.0.450	M001464	287.4.581	15619	306.2.320
644425	276.0.390	M060770	287.4.600	15634	277.4.507
659561	292.0.380	M078580	294.1.452	15634	277.4.500
67306	277.2.500	UJB 0203-001	278.2.511	15635	277.4.420
683392	292.0.380	UJB 0358	278.1.510	15670	291.2.260
689677	276.0.390	UJB0305	287.4.580	15732	294.2.450
696229	276.0.390	UJY 0099	278.1.510	HANOMAG HENSCHEL	
818225	292.0.520	XCM1331	287.4.600	536905265	297.0.390
DENNIS		FRUEHAUF-ACERBI-TRAILOR		536905266	297.0.390
650292	299.0.450	M001774	278.1.510	546905134	276.0.390
650292/8	276.0.420	M060924	294.1.450	HENDRICKSON	
650883	299.0.450	GIGANT		505859	277.4.500
650884	299.0.450	166205	292.0.520	505859	277.4.507
DISCOS		166217	292.1.534	506243	277.4.420
946.328.04.01	278.4.535	166217	292.0.533	785168	277.4.420
DROGMOELLER		166226	292.0.450	785170	277.4.500
440320200002-00	297.0.390	166252	292.1.533	785170	277.4.507

I nominativi dei costruttori e i relativi riferimenti originali citati nel presente catalogo sono riportati a puro titolo indicativo. I nostri prodotti non sono originali ma con essi intercambiabili.
The name of manufacturers and the o.e. references mentioned in this catalogue are given for cross-reference purposes only. Our products are not original but interchangeable with.



TABELLA COMPARATIVA MOLLE AD ARIA da codice original AIR SPRINGS CROSS-REFERENCE LIST from O.E code

Cod. originale O.E. code	Cod. GART GART code	Cod. originale O.E. code	Cod. GART GART code	Cod. originale O.E. code	Cod. GART GART code
B 2063	277.4.507	41026285	290.1.396	4746740	298.0.355
B 2063	277.4.500	41026286	290.1.397	4763473	292.0.380
B 2065	277.4.420	4102656	290.1.394	4843220	276.0.330
B 2066	278.2.422	4102657	290.1.395	4843255	298.0.385
HA 100001	278.4.421	41031242	290.1.398	4847671	298.0.385
HS 251087	278.4.535	41031243	290.1.399	5001531180	289.0.460
NA 1816	271.2.200	41270462	290.1.390	5001857612	289.0.460
NA1827	291.2.200	41270463	290.1.391	500301776	296.0.360
Y505801	277.4.500	41270465	290.1.392	500310931	298.0.620
Y505801	277.4.507	41270466	290.1.393	500319479	290.0.480
Y505801	277.4.507	4182227	297.0.390	500324098	286.0.420
Y506201	277.4.420	42107588	274.2.270	500324514	286.2.423
Y507782	287.4.600	42107588	274.2.310	500324515	286.2.422
HEULIEZ		42107595	271.3.293	500330231	286.2.420
0305G	276.0.390	4212432	298.0.385	500330232	286.2.421
303	276.0.390	42126126	274.2.270	500341494	290.0.555
INBUS		42530279	296.0.415	500364663	286.0.550
4840001	276.0.370	42531994	290.0.340	500364686	290.0.440
4840005	276.0.370	42532991	281.2.190	5006223351	290.2.390
4890001	276.0.370	42534924	289.0.450	5006223352	290.2.391
5001051	276.0.301	42536242	292.0.380	504157038	289.0.460
5001098	276.0.370	42559765	290.0.392	6657150	276.0.370
5001964	278.0.270	42559766	290.0.393	8121964	277.4.507
IRISBUS		42559767	290.0.394	8121964	277.4.500
5.000.954.175	299.0.390	42559768	290.0.395	8137291	289.0.300
5.001.843.640	289.0.360	4456111	298.0.355	8139068	298.0.460
5.001.857.612	289.0.460	4714019	276.0.370	8160165	276.0.262
IVECO		4714025	276.0.370	8166050	289.0.350
199563	276.0.260	4716989	276.0.420	8188526	290.0.390
41006926	301.0.235	4722525	276.0.370	8188539	290.0.420
41008929	276.0.300	4735768	276.0.370	8194818	274.2.210
41022620	298.0.515	4736728	276.0.370	8194819	274.2.210
41026260	290.1.420	4738008	276.0.370	93197594	297.0.390
		4746733	297.0.390	97108363	301.0.330

I nominativi dei costruttori e i relativi riferimenti originali citati nel presente catalogo sono riportati a puro titolo indicativo. I nostri prodotti non sono originali ma con essi intercambiabili.
The name of manufacturers and the o.e. references mentioned in this catalogue are given for cross-reference purposes only. Our products are not original but interchangeable with.



TABELLA COMPARATIVA MOLLE AD ARIA da codice original AIR SPRINGS CROSS-REFERENCE LIST from O.E code

Cod. originale O.E. code	Cod. GART GART code	Cod. originale O.E. code	Cod. GART GART code	Cod. originale O.E. code	Cod. GART GART code
98411807	289.0.350				
98445471	296.0.340				
98460983	271.2.200				
98478799	289.0.450				
99458555	306.1.420				
99458557	306.1.420				
99459166	276.0.391				
99482948	290.2.341				
99482949	290.2.340				
9988467	277.4.420				
TO01857	276.0.370				
IVECO-PEGASO					
794686	278.0.430				
795097	278.0.430				
KAESSBOHRER					
4731010000	297.0.390				
4731012000	297.0.390				
4731013000	292.0.450				
4731018000	274.2.310				
4731030000	277.4.500				
4731030000	277.4.507				
4731031000	297.0.390				
4731032000	292.0.520				
4731033000	277.4.500				
4731033000	277.4.507				
4731034200	274.2.310				
4731034200	274.0.310				
4771110000	276.0.390				
4771143000	276.0.390				
4771170000	276.0.390				
4771359000	276.0.390				
4771427000	297.0.390				
4771440000	297.0.390				
4771441000	276.0.390				
		KOGEL			
		6501706	291.2.203		
		LANCIA			
		81720882	291.2.201		
		81723192	281.2.190		
		LECITRAILER			
		SN21502	287.4.512		
		MAGIRUS DEUTZ			
		03422652	272.0.199		
		249.8667 EC506704	297.0.390		
		2491566	276.0.370		
		2498667	297.0.390		
		3452571	271.2.200		
		41822247	297.0.390		
		MAN			
		81.43600.6035	304.1.510		
		81.43600.6037	304.1.513		
		81.43600.6039	302.1.520		
		81.43600.6040	302.1.521		
		81.43600.6041	289.1.513		
		81.43600.6044	289.1.410		
		81.43601.0017	276.0.390		
		81.43601.0022	271.2.200		
		81.43601.0032	289.0.400		
		81.43601.0033	299.0.450		
		81.43601.0036	299.0.450		
		81.43601.0037	299.0.450		
		81.43601.0051	292.0.380		
		81.43601.0056	292.0.450		
		81.43601.0057	292.0.450		
		81.43601.0058	292.0.450		
		81.43601.0059	292.0.380		
		81.43601.0060	292.0.380		
				81.43601.0061	292.0.380
				81.43601.0066	290.0.420
				81.43601.0068	290.0.420
				81.43601.0069	290.0.420
				81.43601.0070	289.0.400
				81.43601.0071	301.0.330
				81.43601.0072	301.0.330
				81.43601.0076	292.0.450
				81.43601.0078	292.0.380
				81.43601.0079	292.0.450
				81.43601.0081	292.0.380
				81.43601.0082	292.0.450
				81.43601.0083	292.0.380
				81.43601.0084	292.0.450
				81.43601.0090	292.0.380
				81.43601.0091	292.0.450
				81.43601.0092	289.0.400
				81.43601.0093	289.0.400
				81.43601.0094	289.0.400
				81.43601.0095	289.0.400
				81.43601.0095	289.0.455
				81.43601.0097	289.0.455
				81.43601.0097	289.0.400
				81.43601.0099	289.0.400
				81.43601.0100	289.0.455
				81.43601.0100	289.0.400
				81.43601.0102	289.0.455
				81.43601.0103	289.0.400
				81.43601.0104	289.0.450
				81.43601.0105	289.0.455
				81.43601.0106	290.0.420
				81.43601.0108	290.0.420
				81.43601.0109	289.0.450
				81.43601.0110	301.0.330

I nominativi dei costruttori e i relativi riferimenti originali citati nel presente catalogo sono riportati a puro titolo indicativo. I nostri prodotti non sono originali ma con essi intercambiabili.
The name of manufacturers and the o.e. references mentioned in this catalogue are given for cross-reference purposes only. Our products are not original but interchangeable with.



TABELLA COMPARATIVA MOLLE AD ARIA da codice original AIR SPRINGS CROSS-REFERENCE LIST from O.E code

Cod. originale O.E. code	Cod. GART GART code	Cod. originale O.E. code	Cod. GART GART code	Cod. originale O.E. code	Cod. GART GART code
81.43601.0111	289.0.450	3373270001	276.0.370	A9463281401	294.0.455
81.43601.0113	292.0.380	3633280001	292.0.380	A9743200417	299.1.460
81.43601.0114	292.0.450	3633280201	289.0.450	A9743204321	299.1.460
81.43601.0115	292.0.380	3643277001	276.0.390	A9743280001	299.0.460
81.43601.0116	292.0.450	3823277201	276.0.420	MERCEDES / DISCOS	
81.43601.0117	292.0.380	3833270001	276.0.370	A946 328 1501	277.2.520
81.43601.0118	292.0.450	3873280001	299.0.450	METRO CAMEL WEYMANN	
81.43601.0120	289.0.450	3873280101	299.0.450	X 6641056	299.0.450
81.43601.0121	289.0.400	946.328.04.01	278.4.535	MIELE	
81.43601.0123	289.0.450	9463281401	294.2.454	010ML0020	276.1.261
81.43601.0125	289.0.450	A0003270101	276.0.390	NEOPLAN	
81.43601.0126	289.0.455	A3073280101	299.0.450	1001 102 00	292.0.380
81.43601.0126	299.0.450	A3603280101	299.0.450	1001 122 51	292.0.380
81.43601.0128	301.0.330	A3632290001	292.0.380	1001-101-00	292.0.520
81.43601.0132	289.0.400	A3633280101	299.0.450	1001-103-00	276.0.390
81.43601.0140	289.0.450	A3833270001	276.0.370	1001-122-50	297.0.390
81.43601.0150	289.0.450	A3933280101	298.0.355	1001-122-54	276.0.390
81.43601.0151	289.0.512	A6583280001	290.0.420	1001-123-00	299.0.450
81.43601.0152	304.0.511	A9423200107	299.1.461	1021-002-00	292.0.520
81.43601.0153	304.0.513	A9423200117	299.1.461	AA 10-01-002	292.0.380
81.43601.0155	302.0.521	A9423200121	304.1.440	M 10-01-001	297.0.390
81.43601.0160	289.0.411	A9423200221	304.1.441	NEWAY	
81.43601.6036	289.1.510	A9423200321	304.1.444	211586	277.4.420
81.43601.6038	289.1.513	A9423200421	304.1.443	22282	277.4.507
90.83112.0018	292.0.380	A9423202221	282.1.461	22282	277.4.500
90.83112.0144	297.0.390	A9423202221	282.0.461	90557023	292.0.450
MENCI		A9423202321	282.0.460	90557027	278.0.421
03234	291.2.200	A9423202321	282.1.460	90557027	278.2.422
MERCEDES		A9423203221	299.1.461	90557075	278.2.422
3073270001	276.0.390	A9423204921	304.1.440	90557077	278.0.421
3073270101	276.0.390	A9423205021	304.1.441	90557233	294.1.452
3073280001	276.0.390	A9423270001	299.0.461	MO 557019	306.1.420
3073280101	292.0.450	A9423280001	304.0.440	MO 557020	306.1.420
3273280001	276.0.390	A9423280101	304.0.441		

I nominativi dei costruttori e i relativi riferimenti originali citati nel presente catalogo sono riportati a puro titolo indicativo. I nostri prodotti non sono originali ma con essi intercambiabili.
The name of manufacturers and the o.e. references mentioned in this catalogue are given for cross-reference purposes only. Our products are not original but interchangeable with.



TABELLA COMPARATIVA MOLLE AD ARIA da codice original AIR SPRINGS CROSS-REFERENCE LIST from O.E code

Cod. originale O.E. code	Cod. GART GART code	Cod. originale O.E. code	Cod. GART GART code	Cod. originale O.E. code	Cod. GART GART code
MO 557030	306.1.420	112273	271.3.298/1	21226046	278.4.421/1
MO 557031	306.1.420	112321	271.3.298	21227225	287.4.600
OMAR		112322	278.2.512	21229214	294.0.461
11804	277.2.500	112323	271.3.298/2	21229214	294.2.460
11808	278.2.512	112331	291.2.203/1	RVI	
11815	287.2.670	700734	278.1.510	5.000.786.516	302.0.385
PEGASO		811905	277.4.420	5.000.869.135	302.0.385
175005	277.4.507	ROR - MERITOR		5.000.954.175	302.0.385
175005	277.4.500	17204517	277.4.420	5.000.954.176	302.0.385
931410	287.4.510	21208082	277.4.420	5000288982	276.0.391
PEZZAIOLI		21208939	278.2.422	5000452939	277.4.420
70100007	278.2.340	21212549	275.1.120	5000745918	277.4.506
70100010	278.2.437	21215632	277.4.420	5000786901	292.0.380
70100027	287.2.670	21215633	287.4.510	5000787632	276.0.420
70100029	277.2.420	21215633	277.4.500	5000790692	277.4.500
70100044	278.2.491	21215633	277.4.507	5000790692	277.4.507
70100045	278.2.401	21215761	278.4.421	5000819517	292.0.380
70100047	293.2.414/PE	21215762	278.4.421	5000869179	276.0.420
70100048	293.2.514/PE	21215891	278.4.511	5000954176	276.0.420
70102000	282.2.535	21216135	278.2.422	5001294309	294.1.530
PIACENZA		21221307	294.0.455	5001488070	294.1.530
250991	277.4.507	21221307	294.2.451	5001829866	297.0.390
250991	277.4.500	21221349	287.4.580	5001832067	287.1.600
PORTESI		21221356	291.2.260	5001832067	287.0.601
700176	276.0.370	21222239	277.4.507	5001855856	294.0.531
ROLFO		21222239	287.4.521	5010130925	277.4.507
112007	274.2.270	21222442	294.2.450	5010130925	277.4.500
112010	287.2.670	21222442	294.0.451	5010151378	276.0.391
112060	277.2.500	21222663	291.2.200	5010151379	276.0.391
112063	295.2.510	21222673	287.4.600	5010239971	287.1.540
112064	287.2.510	21223346	275.1.180	5010294307	287.0.601
112186	271.2.204	21225695	278.2.342	5010294307 C	287.1.600
112269	292.0.520	21225697	274.2.210	5010294385	290.0.420
		21226039	278.4.511/1	5010557355	287.1.603

I nominativi dei costruttori e i relativi riferimenti originali citati nel presente catalogo sono riportati a puro titolo indicativo. I nostri prodotti non sono originali ma con essi intercambiabili.
The name of manufacturers and the o.e. references mentioned in this catalogue are given for cross-reference purposes only. Our products are not original but interchangeable with.



TABELLA COMPARATIVA MOLLE AD ARIA da codice original AIR SPRINGS CROSS-REFERENCE LIST from O.E code

Cod. originale O.E. code	Cod. GART GART code	Cod. originale O.E. code	Cod. GART GART code	Cod. originale O.E. code	Cod. GART GART code
5010557356	287.1.541	2229000700	278.4.452	3229003100	277.4.505
5010600328	287.1.602	2229000700	278.4.451	3229003300	278.1.455
5010600439	287.1.542	2229000900	287.4.510	3229003600	277.4.424
5011239971	287.0.541	2229100100	271.2.200	3229003800	278.1.453
5011294308	287.0.541	2229100100	271.2.204	3229003900	278.1.452
S.T. SYSTEM TRUCK		2923VK	277.4.508	3229100100	271.2.200
05101002	278.2.422	2926V	287.4.601	3229263000	287.4.601
05101005	276.1.261	3228000300	277.4.507	4229100400	291.2.203
05101006	276.1.481	3228000300	277.4.500	4229100500	291.2.263
05101009	277.2.420	3228002700	277.4.505/1	4229100501	291.2.263
05101010	291.1.170	3228003000	287.4.601/1	4284300301	278.4.452
05101012	278.2.492	3228003100	277.4.505/2	SAF - MENCI	
05101013	279.1.195	3228003500	278.4.517	3229004000	278.4.456
05101014	277.4.422	3228100100	271.2.200	3229104300	278.1.454
05101100	296.1.340	3228102700	277.4.424/1	SAMRO	
05101102	276.1.264	3228103000	287.1.604	2500915	278.4.535
05101103	276.1.372	3228103100	277.1.505	H25000361	287.4.580
05101501	271.3.290	3229000300	277.4.507	H2501122	294.1.530
05101505	271.3.295	3229000300	277.4.500	SANSAVINI	
05101510	271.2.200	3229000500	287.4.600	F3034A	275.1.120
05101511	271.2.250	3229000601	287.4.600	SPMHB016	278.2.433
05101512	291.2.260	3229000700	278.4.452	SAURER	
05101520	274.2.270	3229000701	278.4.452	9534175010	271.2.200
05101522	274.2.310	3229000702	278.4.452	9534175020	271.2.200
SAE		3229000702	278.4.453	SCANIA	
8403/102	277.4.500	3229001300	287.4.600	1107647	287.4.520
8403/102	277.4.507	3229001301	287.4.520	1107674	287.4.520
9212050	277.4.420	3229001800	277.4.500	1314903	306.2.320
SAF		3229001800	277.4.507	1314906	287.4.520
1319761	291.2.262	3229002400	287.4.580	1319761	291.2.203
222800200	277.4.420	3229002700	277.4.423	1362145	278.2.415
2229000200	277.4.420	3229002900	278.4.453	1362147	278.2.500
2229000300	277.4.507	3229002900	278.4.454	1370743	278.2.415
2229000300	277.4.500	3229003000	287.4.601		

I nominativi dei costruttori e i relativi riferimenti originali citati nel presente catalogo sono riportati a puro titolo indicativo. I nostri prodotti non sono originali ma con essi intercambiabili.
The name of manufacturers and the o.e. references mentioned in this catalogue are given for cross-reference purposes only. Our products are not original but interchangeable with.



TABELLA COMPARATIVA MOLLE AD ARIA da codice original AIR SPRINGS CROSS-REFERENCE LIST from O.E code

Cod. originale O.E. code	Cod. GART GART code	Cod. originale O.E. code	Cod. GART GART code	Cod. originale O.E. code	Cod. GART GART code
1370744	278.2.500	1726240	297.1.430/1	751065	278.0.531
1379392	287.0.603	1726241	297.1.431/1	S015323	277.2.520
1379392	287.1.606	1726243	297.1.432/1	SEG-SAMRO	
1379392	282.1.600	1726246	297.1.300/1	2500008	277.4.420
1379392	282.0.601	1726257	297.2.315/1	25004	277.4.507
1379393	282.1.600	1834970	297.1.431	25004	277.4.500
1379393	287.0.603	255293	287.4.520	25008	277.4.420
1379393	287.1.606	255295	287.4.520	2509999	277.4.420
1379393	282.0.601	298568	287.4.520	H2500324	278.1.510
1386199	278.2.415	325748	287.4.520	SETRA	
1386200	278.2.500	402315	278.0.430	1590136	276.0.390
1387283	291.2.262	411622	278.0.430	4771441000	276.0.390
1387289	291.2.203	411623	278.0.430	SICCA	
1394997	306.2.320	412418	278.0.430	4840005	276.0.370
1402423	306.2.320	470920	278.2.300	SMB	
1434506	297.1.432	470921	278.2.330	R915	294.1.450
1434930	295.1.475	470922	297.1.430	STEYR	
1434933	287.1.480	475149	297.1.300	99100520019	287.4.510
1440294	282.0.601	488263	297.2.315	TECMA	
1440294	282.1.600	488264	297.1.432	11041002	275.1.171
1440294	287.0.603	488266	278.2.330	11041011	277.4.500
1440294	287.1.606	492680	297.1.431	11041011	277.4.507
1440301	278.2.300	523229	290.0.390	11041015	287.4.510
1440302	278.2.330	SCHMITZ		11041022	274.2.214
1440303	297.2.315	015323	287.4.540	11041027	277.4.420
1440304	297.1.430	016808	291.2.260	TECNOKAR	
1440305	297.1.431	750 209	292.0.380	033ACC010001	294.2.485
1440307	297.1.300	750208	297.0.390	TERBERG	
1475106	297.2.315	750212	292.0.450	21071483	277.4.500
1515499	278.2.330	750215	292.0.520	21071483	277.4.507
1521114	297.2.315	750999	278.1.530/1	TITAN	
1726237	278.2.300/1	750999	278.1.530	91687700000	277.4.507
1726238	278.2.330/1	751065	294.0.453		
1726239	297.2.315/1	751065	294.1.451		

I nominativi dei costruttori e i relativi riferimenti originali citati nel presente catalogo sono riportati a puro titolo indicativo. I nostri prodotti non sono originali ma con essi intercambiabili.
The name of manufacturers and the o.e. references mentioned in this catalogue are given for cross-reference purposes only. Our products are not original but interchangeable with.



TABELLA COMPARATIVA MOLLE AD ARIA da codice original AIR SPRINGS CROSS-REFERENCE LIST from O.E code

Cod. originale O.E. code	Cod. GART GART code	Cod. originale O.E. code	Cod. GART GART code	Cod. originale O.E. code	Cod. GART GART code
91687700000	277.4.500	624319-610	276.0.390	1076594	293.1.460
TRAILOR		624319-614	292.0.450	1076595	293.0.461
36158	277.4.507	624319-630	276.0.390	1079718	278.0.471
36158	277.4.500	624319-640	292.0.450	1080707	277.4.420
65022347Y	277.4.507	624319-670	297.0.390	1082085	301.0.330
65022347Y	277.4.500	624319-690	297.0.390	1134445	276.0.390
65023482	277.4.507	624319-700	297.0.390	1134446	292.0.450
65023482	277.4.500	624319-860	276.0.370	1137882	297.0.390
6504646G	277.4.420	VIBERTI		1137888	297.0.390
TRANSPART		128118102	274.2.210	1199873	276.0.390
520 728	278.2.422	128118103	271.3.290	1199893	276.0.390
TRAS CAR		128118107	271.3.294	1590136	276.0.390
03003000000	276.1.261	128147101	295.2.470	1590136	299.0.450
03003000010	271.3.290	128147102	277.2.500	1593842	297.0.390
03003000020	274.2.210	128147104	295.2.510	1611776	276.0.370
03003000030	274.2.270	128147109	278.4.514	1612455	302.0.385
03003000040	275.1.120	128147111	278.4.516	1612465	302.0.385
03003000060	276.1.481	128147112	277.2.504	1622111	276.0.390
03003000065	276.1.372	128147114	295.2.511	1622115	299.0.490
03003000070	276.1.421	128147117	287.2.510	1622115	299.0.450
03003000080	278.2.432	128147121	278.1.511	1622116	304.0.490
03003000090	272.2.190	128147122	277.4.500	1629193	299.0.450
03003000099	291.2.202	128147122	277.4.507	20374510	295.1.465
03003000100	296.1.340	128147123	278.1.510	20374511	295.1.400
TROUILLET		128147124	277.2.504	20375226	294.1.430
HB 10315	277.4.420	644285	277.4.500	20375227	294.1.430
HT 18002	278.1.510	644285	277.4.507	20427800	294.1.430
ST 225-675	277.4.500	VOLVO		20427801	294.1.370
ST 225-675	277.4.507	1075290	299.0.490	20427803	294.0.431
VAN HOOL		1075363	278.1.470	20427804	294.1.370
3422596	292.0.380	1075890	294.1.430	20456150	294.0.431
624319-420	276.0.390	1076076	278.1.355	20456150	294.1.430
624319-600	276.0.390	1076416	295.1.465	20456152	295.1.465
		1076418	295.1.400	20456154	294.1.370

I nominativi dei costruttori e i relativi riferimenti originali citati nel presente catalogo sono riportati a puro titolo indicativo. I nostri prodotti non sono originali ma con essi intercambiabili.
The name of manufacturers and the o.e. references mentioned in this catalogue are given for cross-reference purposes only. Our products are not original but interchangeable with.



TABELLA COMPARATIVA MOLLE AD ARIA da codice original AIR SPRINGS CROSS-REFERENCE LIST from O.E code

Cod. originale O.E. code	Cod. GART GART code	Cod. originale O.E. code	Cod. GART GART code	Cod. originale O.E. code	Cod. GART GART code
20456156	295.1.400	US 07074F	277.4.424	ZORZI	
20531984	294.1.430	US 07337F	277.4.420		
20531985	295.1.465	US 073387 RP	277.2.422		
20531986	294.1.370	US 07345	277.4.500		
20531987	295.1.400	US 07345	277.4.507		
20554759	278.1.470	US 07380F	287.4.580		
20582206	294.1.430	US 07394	291.2.260		
20582209	294.1.370	US 07394C	291.2.260		
20582214	295.1.400	US 07394F	291.2.260		
20582215	295.1.465	US 35864	278.2.422		
20722412	287.1.603	US 35864F	278.4.421		
20726769	287.1.542	US 6316F	294.0.453		
20726769	287.1.602	US 6316F	294.1.451		
2680421000	299.0.490	US 6910F	291.2.200		
3159252	276.0.390	US 7385F	287.4.600		
3159253	297.0.390	US 86318F	294.1.500		
3171694	294.1.370	US 87408F	277.4.500		
3171695	295.1.400	US 87408F	277.4.507		
365461	291.2.201	US 874131F	277.4.420		
6797169	304.0.490	US 87413P	277.4.420		
6885533	292.0.380	US 93800	278.4.511		
70321694	294.1.370	US 93918	287.4.510		
8158106	293.0.461	US 96681F	287.4.600		
WEWELER		US 97306	278.4.421		
US 00622	277.4.420	US04028	287.4.540		
US 04030P	277.2.520	US06287F	294.2.502		
US 06285F	278.1.530	US06288F	294.2.501		
US 06285F	278.1.530/1	US07074	294.2.450		
US 06286FS	277.4.420	US08840	294.2.450/1		
US 06345	277.4.420	YORK			
US 06364FS	277.4.500	506243/01	277.4.420		
US 06364FS	277.4.507	785168	277.4.420		
US 06364FS	277.4.507	785170	277.4.507		
US 06364FS	277.4.500	785170	277.4.500		
				1006500	272.2.190
				1006505	271.3.293
				1006506	271.3.290
				1006508	275.1.120
				1006509	274.2.310
				1006545	277.2.503
				1006546	277.2.421
				1006549	295.2.470
				1006550	278.2.422
				1006551	278.2.512
				1006552	287.4.581
				1006553	277.2.500
				1006554	287.2.510
				1006555	295.2.510
				1006557	287.2.670
				1006559	278.4.514
				1006562	277.2.420
				1006564	278.1.510
				1006565	277.2.504

I nominativi dei costruttori e i relativi riferimenti originali citati nel presente catalogo sono riportati a puro titolo indicativo. I nostri prodotti non sono originali ma con essi intercambiabili.
The name of manufacturers and the o.e. references mentioned in this catalogue are given for cross-reference purposes only. Our products are not original but interchangeable with.



**TABELLA COMPARATIVA MOLLE AD ARIA da codici GART
AIR SPRINGS CROSS-REFERENCE LIST from GART codes**

GART		CF Gomma		Firestone		Phoenix		Contitech		Goodyear		Airtech		Sabo	
Codice Code	Tipo - Type	Codice - Code	Tipo - Type	Codice - Code	Tipo - Type	Codice - Code	Tipo - Type	Codice - Code	Tipo - Type	Codice - Code	Tipo - Type	Codice - Code	Tipo - Type	Codice - Code	Tipo - Type
271.2.200	T271/2	88544	22	W01-M58-7524	22 D	2 B 22 R									
271.2.204	T271/2	86624	22 B							2B12-425					
271.3.290	T271	89413	322 BR	W01-M58-7992	38 C										
271.3.293	T271	87987	322	W01-M58-7992	38 C							3B-300Hyd / 115005		SA520136	
271.3.294	T271/S	88505	322 BB												
271.3.296	T271/S														
271.3.298	T271/S	204413	322 BB									3B-300 / 115008		SA520108	
271.3.298/1	T271/S	93410	322 BB									3B-300 / 115002		/	
271.3.298/2	T271/S	204450	322 BB									3B-310Hyd / 115009		SA520206	
272.0.199	T272/N			W01-095-0219	260	2 B 15 R		620 N							
272.2.190	T272/N	93740	245												
274.0.310	T274/B	97141 (ex 89749)	21 B	W01-R58-4089	271										
274.2.210	T274	89457	21 BR	W01-M58-7710	233 C							2B-370Hyd / 113361		SA520137	
274.2.270	T274/C	97300	21A BR	W01-M58-6989	21 - D2	2 B 34 RA									
274.2.310	T274/B	92154	21B BR	W01-M58-7527	233-D2										
274.3.300	T274/3	88110	321	W01-M58-7526	313 D										
275.1.120	T275	88540 / 204626	110												
276.0.260	D276/D	88809	1S 285-18	W01-095-0189	1R 1A 260 285			943 N		9001		3943		SA520026	
276.0.262	new D276/DS	97261	1S 285-18C											SA520279	
276.0.300	D276/F	201732	1S 270-19												
276.0.301	new D276/FS	97614	1S 285-19C												
276.0.330	D276/E	96534	1S 285-20										320285	SA520153	
276.0.370	D276/C	88786	1S 285-22	W01-095-0198	1R 1A 370 285			944 N		8012		3944		SA520035	
276.0.390	D276/B	92574	1S 285-24	W01-095-0118	1R 1A 390 295			644 N		8017		3644		SA520002	
276.0.391	D276/BS	202728	1S 285-23V												
276.0.420	D276	97555	1S 285-25	W01-095-0197	1R 1A 415 285			945 N		9013		3945		SA520003	
276.1.420	D276/R											361420 K		SA520149C	
276.1.421	D276/R											361421 K		SA520144C	
276.1.480	D276/LR											361480 K		SA520148C	
276.1.481	D276/LR											361481 K		SA520145C	
276.2.421	D276/R											362421 K		SA520167C	
277.0.424	D277/B							810 N				3810			

I nominativi dei costruttori e i relativi riferimenti originali citati nel presente catalogo sono riportati a puro titolo indicativo. I nostri prodotti non sono originali ma con essi intercambiabili.
The name of manufacturers and the o.e. references mentioned in this catalogue are given for cross-reference purposes only. Our products are not original but interchangeable with.



TABELLA COMPARATIVA MOLLE AD ARIA da codici GART
AIR SPRINGS CROSS-REFERENCE LIST from GART codes

GART		CF Gomma		Firestone		Phoenix		Contitech		Goodyear		Airtech		Sabo	
Codice Code	Tipo - Type	Codice - Code	Tipo - Type	Codice - Code	Tipo - Type	Codice - Code	Tipo - Type	Codice - Code	Tipo - Type	Codice - Code	Tipo - Type	Codice - Code	Tipo - Type	Codice - Code	Tipo - Type
277.0.504	D277								811				3811-02		
277.1.505	new D277	207735	1T 19 E-2												
277.2.420	D277/B	204357	1T 19E-1	W01-M58-6344	1T 19 L-7										
277.2.421	D277/B	96884	1T 19 E-1	W01-M58-8772	1T 19 L-7	1 DK 28 A7							36884 K	SA520162C	
277.2.422	D277/B					1 D 28 A13									
277.2.500	D277/2F	204371 (ex 93762)	1T 19 E-2	W01-M58-6361	1T 19 L-11	1 DK 28 B7				1R 14-706			391318 K	SA520021C	
277.2.503	D277	96885	1T 19 E-2	W01-M58-8794	1T 19 L-11								36885 K	SA520163C	
277.2.504	D277/2F	97730	1T 19 E-2	W01-M58-6363	1T 19 L-11									SA520021C/1	
277.2.520	D277/D					1 D 28 F3							30283 K	SA520230C	
277.4.420	D277/B	87413/1	1T 19 E-1	W01-M58-6345 / 8775	1T 19 L-7	1 D 28 A2		810 MB		1R 14-716			3810 K	SA520010C	
277.4.423	D277/B	205456	1T 19 E-1	W01-M58-6338	1T 19 L-7	1 D 28 A10		4810 NP05		1R 14-730			32918 K	SA520146C	
277.4.424	D277/B	205868	1T 19 E-1												
277.4.424/1	new D277/B	207733	1T 19 E-1												
277.4.500	D277	87408	1T 19 E-2	W01-M58-6364 / 6339	1T 19 L-11	1 D 28 B2		813 MB		1R 14-705 (061)			3813 K	SA520070C	
277.4.501	D277/C			W01-M58-6360	1T 19 L-11										
277.4.505	D277	204676	1T 19 E-2	W01-M58-6348	1T 19 L-11	1 D 28 B10		4023 NP03		1R 14-729			34023 K	SA520059C	
277.4.505/1	new D277	207732	1T 19 E-2												
277.4.505/2	new D277	207734	1T 19 E-2												
277.4.506	D277	203878	1T 19E-2	W01-M58-6334	1T 19 F-11	1 D 28 B7		811 MB 3 st		1R 14-718			3811 K	SA520081C	
277.4.507	D277	87408	1T 19 E-2	W01-M58-6364 / 6339	1T 19 L-11	1 D 28 B2		813 MB		1R 14-705 (061)			3813 K	SA520207C	
277.4.508	D277												32923 KPP	SA520207C	
277.4.520	D277/D												3813-03 K	SA520169C	
277.4.521	D277/DA												374521 K	SA520166C	
278.0.270	D278/C	89405	1S 320-17												
278.0.355	D278/B	88806	1S 320-23											SA520280	
278.0.421	D278/G							4156 NP05					34156	SA520080	
278.0.430	D278	88788	1S 320-30										3897	SA520032	
278.0.434	D278/R														
278.0.451	D278/S													SA520062	
278.0.452	D278/S			W01-M58-0756	1T 17 BS-6			4004 NP02		1R 11-705			34004	SA520055	
278.0.471	D278/V							4022 NP02		1R 11-709			34022		
278.0.471	D278/V							9718 N							
278.0.511	D278/H	206506	1T 323-40					4159 NP05		1R 12-761			34159	SA520117	

I nominativi dei costruttori e i relativi riferimenti originali citati nel presente catalogo sono riportati a puro titolo indicativo. I nostri prodotti non sono originali ma con essi intercambiabili.

The name of manufacturers and the o.e. references mentioned in this catalogue are given for cross-reference purposes only. Our products are not original but interchangeable with.



TABELLA COMPARATIVA MOLLE AD ARIA da codici GART
AIR SPRINGS CROSS-REFERENCE LIST from GART codes

GART		CF Gomma		Firestone		Phoenix		Contitech		Goodyear		Airtech		Sabo	
Codice Code	Tipo - Type	Codice - Code	Tipo - Type	Codice - Code	Tipo - Type	Codice - Code	Tipo - Type	Codice - Code	Codice - Code	Codice - Code	Codice - Code	Codice - Code	Codice - Code	Codice - Code	Codice - Code
278.0.531	D278/HS			W01-M58-6257	1T 15 MP-9			4158 NP02				34158		SA520091	
278.1.355	D278/V1	207774	1TS 300-28					4420 NP01							
278.1.430	D278/R			W01-358-9780	1T 15 ZR-6	1 DK 23 K-9780				1R 12-603					
278.1.452	new D278/S	207722	1T 300-37												
278.1.453	new D278/S	207719	1T 300-37												
278.1.454	new D278/S	207718	1T 300-37												
278.1.455	D278/S	206585	1T 300-37	W01-M58-8612	1T 17 BS-6			4022 NP05				32619 KPP		SA520131C	
278.1.470	D278/V							4718 NP01				34718 K		SA520121C	
278.1.510	D278/H	200751	1T 323-40	W01-M58-9131	1T 15 M-9	1 DK 23 L-9131		4159 NP09		1R 12-721		34159-02 KPP		SA520094C	
278.1.511	D278/H	201099	1T 323-40												
278.1.530	D278/HS			W01-M58-8185	1T 15 MPW-9	1 DK 20 B1		4158 NP03		1R 12-749		34158 KPP		SA520091C	
278.1.530/1	new D278/HS			W01-M58-8185	1T 15 MPW-9	1 DK 20 B1		4158 NP03		1R 12-749		34158 KPP		SA520091C	
278.2.300	D278/NA			W01-M58-8192	1T 15 VR-3					1R 13-746		330301 K		SA520198C	
278.2.300/1	new D278/NA									1R 13-750		331237 K			
278.2.330	D278/N			W01-M58-8193	1T 15 VPR-3					1R 12-809		330302 K		SA520205C	
278.2.330/1	new D278/N									1R 12-813		331238 K			
278.2.415	D278/MA											36199 K		SA520140C	
278.2.422	D278/G	96873	1T 323-33							1R 12-705				SA520142C	
278.2.430	D278/E											382430 K		SA520139C	
278.2.500	D278/M											36200 K		SA520128C	
278.2.511	D278/H	202302 / 96978	1T 323-40	W01-379-9091 / 8859	1T 15 M-9	1 DK 23L-25		4159 NP07		1R 12-702		34159-05 K		SA520023C	
278.2.512	D278/H	96871	1T 323-40	W01-M58-6289	1T 15 M-9					1R 12-703		391209 K		SA520023C	
278.2.515	D278/H											34159 K		/	
278.2.520	D278/F			W01-358-9361	1T 15 M-6							382520 K		SA520143C	
278.4.421	D278/G	97306 / 207777	1T 323-32	W01-R88-6268	1T 15 M-6	1 DK 21 A2		4156 NP06		1R 12-707		34156 KPP		SA520089C	
278.4.421/1	D278/G														
278.4.451	D278/S	97722 (ex 97334)	1T 323-33		1T 17 BS-6									SA520062C	
278.4.452	D278/S	203715	1T 300-37	W01-M58-6366	1T 17 BS-6	1 DK 22 E8		4004 NP03		1R 11-713		34004 KPP		SA520090C	
278.4.453	D278/S	206340 (ex 204677)	1T 300-37	W01-M58-6367	1T 17 BS-6	1 DK 22 E9		4022 NP03		1R 11-710		34022 K		SA520055C	
278.4.454	D278/S	207717	1T 300-37							1R 11-714		34022 KPP		SA520095C	
278.4.456	new D278/S														
278.4.511	D278/H	204124/93800	1T 323-40	W01-M58-7548	1T 15 M-9	1 DK 23L-27		4159 NP03		1R 12-701		34159-10 KPP			

I nominativi dei costruttori e i relativi riferimenti originali citati nel presente catalogo sono riportati a puro titolo indicativo. I nostri prodotti non sono originali ma con essi intercambiabili.
The name of manufacturers and the o.e. references mentioned in this catalogue are given for cross-reference purposes only. Our products are not original but interchangeable with.



**TABELLA COMPARATIVA MOLLE AD ARIA da codici GART
AIR SPRINGS CROSS-REFERENCE LIST from GART codes**

GART		CF Gomma		Firestone		Phoenix		Contitech		Goodyear		Airtech		Sabo	
Codice Code	Tipo - Type	Codice - Code	Tipo - Type	Codice - Code	Tipo - Type	Codice - Code	Tipo - Type	Codice - Code	Codice - Code	Codice - Code	Codice - Code	Codice - Code	Codice - Code	Codice - Code	Codice - Code
278.4.511/1	D278/H			W01-R88-8849	1T 15 M-9							391210-01 K		SA520168C	
278.4.512	D278/H											391210 K 1		SA520006C/1	
278.4.514	D278/H	96864	1T 323-40		1T 15 M-9							391210 K		SA520006C	
278.4.516	D278/H	97307	1T 323-40 BG								1R 12-703				
278.4.517	new D278/H1	207714	1T 323-40 TYPE												
278.4.535	new D278/D			W01-M58-8747	1T 17 B-11	1 DK 25-1					1R 13-150		30081 K		
281.2.190	T281	84181	26	W01-M58-6988	26	2 B 07 N		603 N							
282.0.460	C282/C							4183 N1							
282.0.461	C282/C							4183 N2							
282.1.460	C282/C							4183 NP24					34183-24 K	SA520204C	
282.1.461	C282/C							4183 NP23							
286.0.420	D286	204427	1S 290-23V												
286.0.550	D286/B	205074	1S 290-30V												
286.2.420	D286	204493	1S 290-23V												
286.2.421	D286	204494	1S 290-23V												
286.2.422	new D286	204460	1S 290-23V												
286.2.423	new D286	204461	1S 290-23V												
287.0.541	D287/E												34911 N	SA520075	
287.0.601	D287/C	206780	1T 19 E4										34912	SA520060	
287.0.603	D287/H	207772	1T 19 E-93	W01-095-0365	1T 19 F-14			4912 NP08					34913	SA520045	
287.1.480	new D287/SC			W01-M58-8633	1T 17 HR-8			4913 NP04			1R 14-755		34933 K		
287.1.540	D287/E	207770	1T 19 E3								1R 13-714		34911 K	SA520075C	
287.1.541	new D287/E	207771	1T 19 E3										34911-04 K		
287.1.542	new D287/E														
287.1.600	D287/C	206779	1T 19 E4	W01-M58-8786	1T 19 L-14	1 DK 28 F4		4911 NP06					34912 K	SA520060C	
287.1.602	new D287/C							4912 NP07							
287.1.603	new D287/C	207769	1T 19 E4					4912 NP13					34912-10 K	SA520241C	
287.1.604	new D287/C	207737	1T 19 E-2L					4912 NP10							
287.1.606	D287/H	206201	1T 19 E-93	W01-M58-9881	1T 19 L-14	1 D 28 H16		4913 NP02					34913 K	SA520045C	
287.2.510	D287/A	97039	Airspring E2	W01-M58-8795	1T 19 L-11						1R 14-753				
287.2.580	new D287/B	204759	1T 19 E-3								1R 14-707				
287.2.670	D287/D	201715	1T 19 E-6										30076 K	SA520147C	

I nominativi dei costruttori e i relativi riferimenti originali citati nel presente catalogo sono riportati a puro titolo indicativo. I nostri prodotti non sono originali ma con essi intercambiabili.
The name of manufacturers and the o.e. references mentioned in this catalogue are given for cross-reference purposes only. Our products are not original but interchangeable with.



TABELLA COMPARATIVA MOLLE AD ARIA da codici GART
AIR SPRINGS CROSS-REFERENCE LIST from GART codes

GART		CF Gomma		Firestone		Phoenix		Contitech		Goodyear		Airtech		Sabo	
Codice Code	Tipo - Type	Codice - Code	Tipo - Type	Codice - Code	Tipo - Type	Codice - Code	Tipo - Type	Codice - Code	Tipo - Type	Codice - Code	Tipo - Type	Codice - Code	Tipo - Type	Codice - Code	Tipo - Type
287.4.510	D287/A	93918	Airspring E2		1T 19 L-11										
287.4.512	D287/A			W01-M58-7502	1T 19L 11	1 D 28 B4				1R 14-709					
287.4.520	D287	97764	Airspring E2	W01-M58-7358	1T 19 L-11	1 D 28 B9		4813 NP07		1R 14-727		34813 K		SA520056C	
287.4.521	D287			W01-M58-7370	1T 19 L-11					1R 14-721					
287.4.522	D287													SA520174C	
287.4.540	new D287/E			W01-M58-8106	1T 19 L-12	1 D 28 F-1		4028 NP02		1R 14-783		34028 K			
287.4.580	D287/B	97343	1T 19 E-3	W01-M58-7380 / 8765	1T 19 L-12	1 D 28 C12				1R 13-734		391303 K		SA520012C	
287.4.581	D287/B	201840	1T 19 E-3	W01-M58-8762	1T 19 L-14	1 DK 28 D3						391304 K		SA520019C	
287.4.600	D287/C			W01-M58-7385 / 8502	1 T19 L14	1 D 28 D2		912 NP02				391314 K		SA520020C	
287.4.601	D287/C	206333 / 207713	1T 19 E-2L					912 NP01		1R 14-728		32926 K		SA520132C	
287.4.601/1	new D287/C	207736	1T 19 E-2L												
289.0.300	C289/B	97613	1SC 260-30												
289.0.301	C289/BS	97326	1SC 240-30BB					817 N							
289.0.350	C289	96987 / 202306	1SC 260-32												
289.0.360	C289/E							1924 N1				31924		SA520155	
289.0.400	C289/D	97042	1SC 250-28	W01-095-0435	1R4R 465 260	1 F16		882 N1							
289.0.411	new C289/M1	207762	1TS 260-20					4885 N1 P01							
289.0.450	C289/C	202265	1SC 270-30	W01-095-0429	1R 2A 445 280	1 F 20 B1		1884 N1 / 1885 N1		9003		31885		SA5200031	
289.0.455	new C289/C1					1 F 21 C-5		916 N1		9015		3916		SA5200097	
289.0.460	new C289/G	207726	1SC 285-30												
289.0.512	C289/M	207760	1TS 260-32					4882 N1 P01				34882		SA520187	
289.1.410	new C289/M1	207764	1TS 260-20					4885 N1 P02							
289.1.510	new C289/M	207701	1TS 260-32	W01-M58-9880	1T 17 TWR-8			4882 N1 P05				34882 K		SA520187C	
289.1.513	new C289/M							4884 N1 P07							
290.0.340	D290/E	202773	1S 270-20V									320270		SA520151	
290.0.390	D290/B	97619	1S 270-23	W01-095-0121	1R 1B 390-270	1 E 21-6				9009		3944		SA5200035	
290.0.392	new D290/BR	207172	1TS 270-23												
290.0.393	new D290/BR	207173	1TS 270-23												
290.0.394	new D290/BR	207170	1TS 270-23												
290.0.395	new D290/BR	207171	1TS 270-23												
290.0.420	D290	97608	1S 270-25	W01-095-0295	1R 1B 415-270	1 E 21 E		782 N				3782		SA520065	
290.0.440	D290/C	203933	1S 270-26												

I nominativi dei costruttori e i relativi riferimenti originali citati nel presente catalogo sono riportati a puro titolo indicativo. I nostri prodotti non sono originali ma con essi intercambiabili.
The name of manufacturers and the o.e. references mentioned in this catalogue are given for cross-reference purposes only. Our products are not original but interchangeable with.



**TABELLA COMPARATIVA MOLLE AD ARIA da codici GART
AIR SPRINGS CROSS-REFERENCE LIST from GART codes**

GART		CF Gomma		Firestone		Phoenix		Contitech		Goodyear		Airtech		Sabo	
Codice Code	Tipo - Type	Codice - Code	Tipo - Type	Codice - Code	Tipo - Type	Codice - Code	Tipo - Type	Codice - Code	Codice - Code	Codice - Code	Codice - Code	Codice - Code	Codice - Code	Codice - Code	Codice - Code
290.0.480	D290/D	203698	1S 270-27												
290.0.555	new D290/F	204268	1S 270-30												
290.1.390	new D290/BR	206686	1TS 270-23	W01-M58-8663	1T 15 LRN-4.5										
290.1.391	new D290/BR	206687	1TS 270-23	W01-M58-8662	1T 15 LRN-4.5										
290.1.392	new D290/BR	206684	1TS 270-23	W01-M58-8665	1T 15 LRN-4.5										
290.1.393	new D290/BR	206685	1TS 270-23	W01-M58-8660	1T 15 LRN-4.5										
290.1.394	new D290/B	204158(ex 206790)	1S 270-23												
290.1.395	new D290/B	204159(ex 206791)	1S 270-23												
290.1.396	new D290/B	204161(ex 206792)	1S 270-23												
290.1.397	new D290/B	204162(ex 206793)	1S 270-23												
290.1.398	new D290/B	204537	1S 270-23												
290.1.399	new D290/B	204538	1S 270-23												
290.1.420	new D290/B	204151(ex 206796)	1S 270-25												
290.2.340	D290/E	203976	1S 270-20V												
290.2.341	D290/E	203992	1S 270-20V												
290.2.390	D290/B	206660	1S 270-23V												
290.2.391	D290/B	206661	1S 270-23V												
291.1.170	T291/B														
291.2.200	T291/2	206797	20	W01-M58-6910 / 6887	20	2 B 12 R		FD 200-19 1/4 M10	2B 9-223	2B 9-223	220-60 / 111150	SA520161			
291.2.201	T291/2	86600	20	W01-M58-6990	20				8325	2B-220 / 113001		SA520079			
291.2.203	T291/2	207773	20	W01-M58-7894	20F	2 B 12 R3		FD 200-19 P04	2B 9-700	2B-220-3 / 113002		SA520106			
291.2.203/1	new T291/2	206657	20												
291.2.260	T291/2B	207776	20L	W01-M58-7394 / 7679	20-2	2 B 12 RA-10		FD 200-25 1/4 M10	2B 9-269						
291.2.262	T291/2B								2B 9-287						
291.2.263	new T291/2B	207065	20L	W01-M58-6891	20-2	2 B 12 RA-3		FD 200-25 P02	2B 9-701						
292.0.380	C292/C	92594	1SC 360-30	W01-095-0207 / 0190	1R1D355-355 / 1R2D390-360	1 E 32		662 N / 762 N	9007 / 9010	3662 / 3762		SA520046 / A520048			
292.0.450	C292/D	92575	1SC 360-34	W01-095-0191 / 0419	1R2D460 360 / 1R2D470 360	1 F 32A / 32A-2		727 N / 728 N	8117	3727 / 3728		SA520084 / A520085			
292.0.461	C292/A	205537	1TC 360-40	W01-M58-8601	1T 66 D-7.0	1 DK 32 K		4881 NP02	1R 14-701	34881		SA520030			
292.0.520	C292/E	92593	1SC 360-43	W01-095-0192	1R2D 530 360	1 F 32 B		719 N	8118	3719		SA520083			
292.0.531	C292	204530	1TC 360-45	W01-M58-8978	1T 66 D-10.8	1 DK 32		881 MB	1R 14-708	3881		SA520029			
292.0.533	C292/S	202964	1TCS 360-45		1T 66 E10.8	1 DF 32		725 NP01	1R 14-704	3725		SA520067			
292.0.601	C292/B			W01-M58-8611	1T 66 F-13.5	1 DK 32 L		942 MB	1R 14-700	3942		SA520068			

I nominativi dei costruttori e i relativi riferimenti originali citati nel presente catalogo sono riportati a puro titolo indicativo. I nostri prodotti non sono originali ma con essi intercambiabili.
The name of manufacturers and the o.e. references mentioned in this catalogue are given for cross-reference purposes only. Our products are not original but interchangeable with.



**TABELLA COMPARATIVA MOLLE AD ARIA da codici GART
AIR SPRINGS CROSS-REFERENCE LIST from GART codes**

GART		CF Gomma		Firestone		Phoenix		Contitech		Goodyear		Airtech		Sabo	
Codice - Code	Tipo - Type	Codice - Code	Tipo - Type	Codice - Code	Tipo - Type	Codice - Code	Tipo - Type	Codice - Code	Codice - Code	Codice - Code	Codice - Code	Codice - Code	Codice - Code	Codice - Code	Codice - Code
292.1.533	C292/S			W01-M58-8610	1T 66 D-10.8	1 DF 32	1 DF 32	725 NP03	1R 14-756	3725-01 K	SA520125C				
292.1.534	C292/S			W01-M58-8969	1T 66 E-10.8	1 DF 32	1 DF 32	725 NP02	1R 14-747	3725 K	SA520067C				
292.2.460	C292/A			W01-M58-8602	1T 66 D-7.0	1 DK 32 K-1	1 DK 32 K-1	4881 MB	1R 14-724	34881-01 K	SA520030C				
292.2.462	C292/A	207309		W01-M58-8666	1T 66 D-7.0	1 DK 32 K-2	1 DK 32 K-2	4881 MB	1R 14-757	34881-01 KPP	SA520130C				
292.2.530	C292	205800		W01-M58-8966	1T 66 D-10.8	1 DK 32-1	1 DK 32-1	881 MB	1R 14-712	3881-01 K	SA520029C				
292.2.531	C292	205171													
292.2.532	C292	206357		W01-M58-8967	1T 66 D-10.8	1 DK 32-2	1 DK 32-2	881 MB	1R 14-748	3881-01 KPP	SA520087C				
293.0.411	C293/A	205536		W01-M58-8613	1T 17 D-4.3	1 DK 21 K	1 DK 21 K	940 MB	1R 11-703	3940	SA520034				
293.0.412	C293/A	207711				1 D 21 K-3	1 D 21 K-3	4960 NP02	1R 11-801	34960	SA520047				
293.0.413	C293/A							4940 NP02		34940	SA520053				
293.0.414	C293/A							4961 NP02		34961	SA520071				
293.0.461	C293/V	206778						4713 N	1R 12-763	34713	SA520072				
293.0.511	C293	204466		W01-M58-8620	1T 17 D-8.3	1 DK 21	1 DK 21	941 MB	1R 11-700	3941	SA520028				
293.0.513	C293							4941 NP02		34941	SA520054				
293.0.514	C293							4962 NP02							
293.0.611	C293/B			W01-M58-8621	1T 17 D-11.8			951 MB	1R 11-704	3951	SA520063				
293.1.460	C293/V	207775		W01-M58-9706		1 DF 22 C1	1 DF 22 C1	4713 NP 02	1R 12-762	34713 K	SA520072C				
293.2.410	C293/A			W01-M58-8609	1T 17 D-4.3	1 DK 21 K-1	1 DK 21 K-1	940 MB	1R 11-763	3940 K	SA520034C				
293.2.412	C293/A	207308		W01-M58-8595	1T 17 D-4.3	1 DK 21 K-2	1 DK 21 K-2	940 MB	1R 11-752	3940 KPP	SA520129C				
293.2.414	C293/A					1 DK 21 K	1 DK 21 K	4960		34960 KPP	SA520047C				
293.2.415	C293/A	207710						4960							
293.2.510	C293	205170		W01-M58-8619	1T 17 D-8.3	1 DK 21-1	1 DK 21-1	941 MB	1R 11-702 / 762	3941 K	SA520028C				
293.2.512	C293	206356		W01-M58-8619	1T 17 D-8.3	1 DK 21-2	1 DK 21-2	941 MB	1R 11-743	3941-01 KPP	SA520088C				
293.2.514	C293							4963 NP01							
293.2.612	C293/B							951 MB							
294.0.431	C294/V							6605 NP01		37803	SA520182				
294.0.451	C294	205598		W01-M58-7074	1T 15 MPW-7	1 DK 21 A3	1 DK 21 A3	4157 NP05		39002-A3	/				
294.0.455	new C294/D									39002-A8 P					
294.0.531	new C294/C							4915 NP03		34915 P					
294.1.370	C294VA			W01-M58-8477	1T 15 LRN-3	1 DF 20 E-1	1 DF 20 E-1	6606 NP01	1R 11-848	37804 K	SA520215C				
294.1.430	C294V			W01-M58-8472	1T 15 LRN-6	1 DF 20 D-1	1 DF 20 D-1	6605 NP01	1R 11-805	37803 K	SA520182C				
294.1.450	C294			W01-M58-6315	1T 15 MPW-7	1 DK 20 A51	1 DK 20 A51	4157 NP10	1R 11-772	39002-A3-01 KPP	SA520127C				

I nominativi dei costruttori e i relativi riferimenti originali citati nel presente catalogo sono riportati a puro titolo indicativo. I nostri prodotti non sono originali ma con essi intercambiabili.
The name of manufacturers and the o.e. references mentioned in this catalogue are given for cross-reference purposes only. Our products are not original but interchangeable with.



**TABELLA COMPARATIVA MOLLE AD ARIA da codici GART
AIR SPRINGS CROSS-REFERENCE LIST from GART codes**

GART		CF Gomima		Firestone		Phoenix		Contitech		Goodyear		Airtech		Sabo	
Codice Code	Tipo - Type	Codice - Code	Tipo - Type	Codice - Code	Tipo - Type	Codice - Code	Tipo - Type	Codice - Code	Tipo - Type	Codice - Code	Tipo - Type	Codice - Code	Tipo - Type	Codice - Code	Tipo - Type
294.1.451	C294			W01-M58-8186	1T 15 MPW-7	1 DK 20 A1	4157 NP06	1R 11-764	38186 KPP			SA520165C			
294.1.452	C294			W01-M58-6317	1T 15 MPW-7	1 DK 20 C-2	4157 NP08	1R 11-773	39002-A3-08 KPP			SA520181C			
294.1.500	C294/HS			W01-M58-6318	1T 15 MPW-9										
294.1.501	new C294/HS			W01-M58-6238	1T 15 MPW-9										
294.1.502	new C294/HS			W01-M58-6287	1T 15 MPW-9										
294.1.530	new C294/C					1 DK 19-1	4915 NP06		34915-01 K						
294.2.450	C294	205598	1TC 300-38	W01-M58-7074	1T 15 MPW-7	1 DK 21 A31	4157 NP09	1R 11-106	39002-A3 KPP			SA520036C			
294.2.450/1	new C294			W01-M58-8840	1T 15 MPW-7	1 DK 21 A3									
294.2.451	C294	207463	1T 300-40	W01-M58-6297	1T 15 MPW-7	1 DK 21 A4	4157 NP04	1R 11-111	39002-A8 KPP			SA520037C			
294.2.454	new C294/D								34157 KPP						
294.2.460	C294/R			W01-R88(M58)-8608	1T 17 DJ-7				38608 KPP			/			
295.1.400	C295/A			W01-M58-8473	1T 15 UR-6		6607 NP01		36418 K			SA520208C			
295.1.465	C295/V			W01-M58-8474	1T 15 UR-9		6608 NP01	1R 10-704	36416 K			SA520175C			
295.1.475	new C295/SC			W01-M58-8653	1T 15 UR-9										
295.2.470	C295/B	93774	1T 280-30												
295.2.510	C295	96692	1T 280-40												
295.2.511	C295	97309	1T 280-40												
295.2.512	C295	201993	1T 280-40												
296.0.340	D296/D	90609	1S 215-22				819 N		3819			SA520154			
296.0.360	D296/C	202189	1S 215-23				1819 N		3819			SA520154			
296.0.375	D296/B	204772	1S 215-24												
296.0.415	D296	201384	1S 215-25												
296.1.340	D296/D	203392	1S 215-22												
297.0.390	D297	91016	1S 310-28-RF	W01-095-0021	1R 1C390-310	1 E 25	661 N	8018	3661			SA520009			
297.1.300	D297/C							1R 11-845	330307 K			SA520197C			
297.1.300/1	new D297/C							1R 11-841	331246 K						
297.1.430	D297/B							1R 11-829	330304 K			SA520196C			
297.1.430/1	new D297/B							1R 11-834	331240 K						
297.1.431	D297/B							1R 11-830	330305 K			SA520202C			
297.1.431/1	new D297/B							1R 11-840	331241 K						
297.1.432	D297/B							1R 11-832	334506 K			SA520201C			
297.1.432/1	new D297/B							1R 11-838	331243 K						

I nominativi dei costruttori e i relativi riferimenti originali citati nel presente catalogo sono riportati a puro titolo indicativo. I nostri prodotti non sono originali ma con essi intercambiabili.
The name of manufacturers and the o.e. references mentioned in this catalogue are given for cross-reference purposes only. Our products are not original but interchangeable with.



TABELLA COMPARATIVA MOLLE AD ARIA da codici GART
AIR SPRINGS CROSS-REFERENCE LIST from GART codes

GART		CF Gomma		Firestone		Phoenix		Contitech		Goodyear		Airtech		Sabo	
Codice Code	Tipo - Type	Codice - Code	Tipo - Type	Codice - Code	Tipo - Type	Codice - Code	Tipo - Type	Codice - Code	Tipo - Type	Codice - Code	Tipo - Type	Codice - Code	Tipo - Type	Codice - Code	Tipo - Type
297.2.315	D297/A									1R 11-833		331114 K		SA520199C	
297.2.315/1 new	D297/A									1R 11-837		331239 K			
298.0.355	D298/E	89756	1S 323-23												
298.0.385	D298/D	96541	1S 323-25												
298.0.460	D298/C	92477	1S 323-34						876 N			3876		SA520101	
298.0.515	D298/B	203833	1S 323-36							8314					
298.0.620	D298	204290	1S 323-40												
299.0.450	C299	88802	1SC 290-30	W01-095-0195	1R 2A 460-295	1 F 21		720 N		9008		3720		SA520044	
299.0.460	C299/A			W01-M58-0910	1R 7Z 460-305-B			4757 N2		9518					
299.0.461	C299/A			W01-M58-0909	1R 7Z 460-305-A			4757 N1		9517					
299.0.490	C299/E			W01-095-0472	1R 2A 490-305			1421 N		9072		31421		SA520092	
299.1.460	C299/A	206786	1VSC 300-26	W01-M58-8522	1R 7Z 460-305-B			4757 NP02/NP09/NP29		9520		34757-02 K		SA520178C	
299.1.461	C299/A	206785	1VSC 300-26	W01-M58-8521	1R 7Z 460-305-A			4757 NP01 / NP21		9519		34757-01 K		SA520177C	
301.0.235	C301/B	201727	1SC 250-19												
301.0.330	C301	204250	1SC 250-29BB							9012					
302.0.376	C302			W01-M58-0776	1T 17 AR 4.5			836 M		1R 12-700		3836		SA520061A	
302.0.376/2	C302			W01-M58-0777	1T 17 AR 4.5			836 M2		1R 12-710		3836-02		SA520040	
302.0.385	C302/A			W01-095-0213	1R2A 380 330			768 N				3768		SA520043	
302.0.521	C302/B							4705 N1 P01				34705 P			
302.1.375	C302			W01-M58-8722	1T 17 AR 4.5			836 MK1		1R 12-712		3836 K		SA520061C	
302.1.375/2	C302			W01-M58-8721	1T 17 AR 4.5			836 M2 K1		1R 12-711		3836-02K		SA520069C	
302.1.520	C302/B							4705 N1 P03							
302.1.521	C302/B							4705 N1 P04							
304.0.440	C304	206782	1VSC 285-30	W01-M58-0904	1R 7Z 440-290-B			4390 N1		9507		34390-01		SA520093	
304.0.441	C304	206784	1VSC 285-30	W01-M58-0905	1R 7Z 440-290-C			4390 N2		9508		34390-02		SA520064	
304.0.490	C304/B							713 N		9066		3713		SA520064	
304.0.511	C304/M4	207759	1TS 290-28					4884 N1 P01		1R 11-820		34884		SA520189	
304.0.513	C304/M3	207761	1TS 290-28					4883 N1 P01		1R 11-804		34883		SA520188	
304.1.440	C304	207765	1VSC 285-30	W01-M58-8514	1R 7Z 440-290-B			4390 NP01 / NP21		9505		34390-01 K		SA520093C	
304.1.441	C304	207766	1VSC 285-30	W01-M58-8513	1R 7Z 440-290-C			4390 NP02 / NP22		9506		34390-02 K		SA520098C	
304.1.443	C304	206783	1VSC 285-30					4390 NP03				34390-03 K			
304.1.444	C304	206781	1VSC 285-30					4390 NP04				34390-04 K			

I nominativi dei costruttori e i relativi riferimenti originali citati nel presente catalogo sono riportati a puro titolo indicativo. I nostri prodotti non sono originali ma con essi intercambiabili.
The name of manufacturers and the o.e. references mentioned in this catalogue are given for cross-reference purposes only. Our products are not original but interchangeable with.



**TABELLA COMPARATIVA MOLLE AD ARIA da codici GART
AIR SPRINGS CROSS-REFERENCE LIST from GART codes**

GART		CF Gomma		Firestone		Phoenix		Contitech		Goodyear		Airtech		Sabo	
Codice Code	Tipo - Type	Codice - Code	Tipo - Type	Codice - Code	Tipo - Type	Codice - Code	Tipo - Type	Codice - Code	Tipo - Type	Codice - Code	Tipo - Type	Codice - Code	Tipo - Type	Codice - Code	Tipo - Type
304.1.510	C304/M4	207702	1TS 290-28	W01-M58-9879	1T 17 JR-7.,2			4884 NI P06				34884 K		SA520189C	
304.1.513	C304/M3							4883 NI P06				34883 K		SA520188C	
305.0.320	D305							975 N							
306.1.420	D306/A			W01-M58-7313	1T 15 LP-6										
306.2.320	D306			W01-M58-6251	1T 15 LP-3							36251 K		SA520185C	

I nominativi dei costruttori e i relativi riferimenti originali citati nel presente catalogo sono riportati a puro titolo indicativo. I nostri prodotti non sono originali ma con essi intercambiabili.
The name of manufacturers and the o.e. references mentioned in this catalogue are given for cross-reference purposes only. Our products are not original but interchangeable with.



**TABELLA COMPARATIVA MOLLE AD ARIA da codici CF GOMMA
AIR SPRINGS CROSS-REFERENCE LIST from CF GOMMA codes**

CF Gamma		GART		Firestone		Phoenix		Contitech		Goodyear		Airttech		Sabo	
Codice - Code	Tipo - Type	Codice - Code	Tipo - Type	Codice - Code	Tipo - Type	Codice - Code	Codice - Code	Codice - Code	Codice - Code	Codice - Code	Codice - Code	Codice - Code	Codice - Code	Codice - Code	Codice - Code
84181	26	281.2.190	T281	W01-M58-6988	26	2 B 07 N	603 N								
86600	20	291.2.201	T291/2	W01-M58-6990	20					8325					
86624	22 B	271.2.204	T271/2							2B12-425					
87408	1T 19 E-2	277.4.507	D277	W01-M58-6364 / 6339	1T 19 L-11	1 D 28 B2	813 MB			1R 14-705 (061)		3813 K		SA520070C	
87408	1T 19 E-2	277.4.500	D277	W01-M58-6364 / 6339	1T 19 L-11	1 D 28 B2	813 MB			1R 14-705 (061)		3813 K		SA520070C	
87413/1	1T 19 E-1	277.4.420	D277/B	W01-M58-6345 / 8775	1T 19 L-7	1 D 28 A2	810 MB			1R 14-716		3810 K		SA520010C	
87987	322	271.3.293	T271	W01-M58-7992	38 C							3B-300Hyd / 115005		SA520136	
88110	321	274.3.300	T274/3		313 D										
88505	322 BB	271.3.294	T271/S												
88540 / 204626	110	275.1.120	T275												
88544	22	271.2.200	T271/2	W01-M58-7524	22 D	2 B 22 R									
88786	1S 285-22	276.0.370	D276/C	W01-095-0198	1R 1A 370 285		944 N			8012		3944		SA520035	
88788	1S 320-30	278.0.430	D278									3697		SA520032	
88802	1SC 290-30	299.0.450	C299	W01-095-0195	1R 2A 460-295	1 F 21	720 N			9008		3720		SA520044	
88806	1S 320-23	278.0.355	D278/B											SA520280	
88809	1S 285-18	276.0.260	D276/D	W01-095-0189	1R 1A 260 285		943 N			9001		3943		SA520026	
89405	1S 320-17	278.0.270	D278/C												
89413	322 BR	271.3.290	T271	W01-M58-7992	38 C										
89457	21 BR	274.2.210	T274	W01-M58-7710	233 C							2B-370Hyd / 113361		SA520137	
89756	1S 323-23	298.0.355	D298/E												
90609	1S 215-22	296.0.340	D296/D												
91016	1S 310-28-RF	297.0.390	D297	W01-095-0021	1R 1C390-310	1 E 25	819 N					3819		SA520154	
92154	21B BR	274.2.310	T274/B	W01-M58-7527	233-D2		661 N			8018		3661		SA520009	
92477	1S 323-34	298.0.460	D298/C												
92574	1S 285-24	276.0.390	D276/B	W01-095-0118	1R 1A 390 295	1 E 21	876 N					3876		SA520101	
92575	1SC 360-34	292.0.450	C292/D	W01-095-0191/0419	1R2D460 360 / 1R2D470 360	1 F 32A / 32A-2	644 N			8017		3644		SA520002	
92593	1SC 360-43	292.0.520	C292/E	W01-095-0192	1R2D 530 360	1 F 32 B	719 N			8117		3727 / 3728		SA520084 / A520085	
92594	1SC 360-30	292.0.380	C292/C	W01-095-0207 / 0190	1R1D355-355 / 1R2D390-360	1 E 32	662 N / 762 N			8118		3719		SA520083	
93410	322 BB	271.3.298/1	T271/S							9007 / 9010		3662 / 3762		SA520046 / A520048	
93740	245	272.2.190	T272/N									3B-310Hyd / 115009		SA520206	
93774	1T 280-30	295.2.470	C295/B												
93918	Airspring E2	287.4.510	D287/A		1T 19 L-11										

I nominativi dei costruttori e i relativi riferimenti originali citati nel presente catalogo sono riportati a puro titolo indicativo. I nostri prodotti non sono originali ma con essi intercambiabili.
The name of manufacturers and the o.e. references mentioned in this catalogue are given for cross-reference purposes only. Our products are not original but interchangeable with.



TABELLA COMPARATIVA MOLLE AD ARIA da codici CF GOMMA
AIR SPRINGS CROSS-REFERENCE LIST from CF GOMMA codes

CF Gomma		GART			Firestone		Phoenix		Contitech		Goodyear		Airtech		Sabro	
Codice - Code	Tipo - Type	Codice - Code	Tipo - Type	Codice - Code	Tipo - Type	Codice - Code	Tipo - Type	Codice - Code	Codice - Code	Codice - Code	Codice - Code	Codice - Code	Codice - Code	Codice - Code	Codice - Code	Codice - Code
96534	1S 285-20	276.0.330	D276/E										320285		SA520153	
96541	1S 323-25	298.0.385	D298/D													
96692	1T 280-40	295.2.510	C295													
96864	1T 323-40	278.4.514	D278/H				1T 15 M-9						391210 K 1		SA520006C/1	
96871	1T 323-40	278.2.512	D278/H				1T 15 M-9					1R 12-703	391209 K		SA520023C	
96873	1T 323-33	278.2.422	D278/G									1R 12-705				
96884	1T 19 E-1	277.2.421	D277/B				1T 19 L-7								SA520162C	
96885	1T 19 E-2	277.2.503	D277				1T 19 L-11								SA520163C	
96987 / 202306	1SC 260-32	289.0.350	C289													
97039	Airspring E2	287.2.510	D287/A				1T 19 L-11					1R 14-707				
97042	1SC 250-28	289.0.400	C289/D				1R4R 465 260						882 N1			
97141 (ex 89749)	21 B	274.0.310	T274/B				271									SA520279
97261	1S 285-18C	276.0.262	D276/DS													
97300	21A BR	274.2.270	T274/C				21- D2									
97306 / 207777	1T 323-32	278.4.421	D278/G				1T 15 M-6						4156 NP06		SA520089C	
97307	1T 323-40 BG	278.4.516	D278/H												SA520006C	
97309	1T 280-40	295.2.511	C295													
97326	1SC 240-30BB	289.0.301	C289/BS										817 N			
97343	1T 19 E-3	287.4.580	D287/B				1T 19 L-12								SA520012C	
97555	1S 285-25	276.0.420	D276				1R 1A 415 285								SA520003	
97608	1S 270-25	290.0.420	D290				1R 1B 415-270								SA520065	
97613	1SC 260-30	289.0.300	C289/B													
97614	1S 285-19C	276.0.301	D276/FS													
97619	1S 270-23	290.0.390	D290/B				1R 1B 390-270								SA520035	
97722 (ex 97334)	1T 323-33	278.4.451	D278/S				1T 17 BS-6								SA520062C	
97730	1T 19 E-2	277.2.504	D277/2F				1T 19 L-11								SA520021C/1	
97764	Airspring E2	287.4.520	D287				1T 19 L-11								SA520056C	
200751	1T 323-40	278.1.510	D278/H				1T 15 M-9								SA520094C	
201099	1T 323-40	278.1.511	D278/H													
201384	1S 215-25	296.0.415	D296													
201715	1T 19 E-6	287.2.670	D287/D				1T 19 LC-20								SA520147C	
201727	1SC 250-19	301.0.235	C301/B													

I nominativi dei costruttori e i relativi riferimenti originali citati nel presente catalogo sono riportati a puro titolo indicativo. I nostri prodotti non sono originali ma con essi intercambiabili.
The name of manufacturers and the o.e. references mentioned in this catalogue are given for cross-reference purposes only. Our products are not original but interchangeable with.



**TABELLA COMPARATIVA MOLLE AD ARIA da codici CF GOMMA
AIR SPRINGS CROSS-REFERENCE LIST from CF GOMMA codes**

CF Gamma		GART		Firestone		Phoenix		Contitech		Goodyear		Airttech		Sabro	
Codice - Code	Tipo - Type	Codice - Code	Tipo - Type	Codice - Code	Tipo - Type	Codice - Code	Tipo - Type	Codice - Code	Tipo - Type	Codice - Code	Tipo - Type	Codice - Code	Tipo - Type	Codice - Code	Tipo - Type
201732	1S 270-19	276.0.300	D276/F												
201840	1T 19 E-3	287.4.581	D287/B	W01-M58-8762	1T 19 L-14	1 DK 28 D3						391304 K		SA520019C	
201993	1T 280-40	295.2.512	C295												
202189	1S 215-23	296.0.360	D296/C					1819 N				3819		SA520154	
202265	1SC 270-30	289.0.450	C289/C	W01-095-0429	1R 2A 445 280	1 F 20 B1		1884 NI / 1885 N1		9003		31885		SA5200031	
202302 / 96978	1T 323-40	278.2.511	D278/H	W01-379-9091 / 8859	1T 15 M-9	1 DK 23L-25		4159 NP07		1R 12-702		34159-05 K		SA520128C	
202728	1S 285-23V	276.0.391	D276/BS												
202773	1S 270-20V	290.0.340	D290/E									320270		SA520151	
202964	1TCS 360-45	292.0.533	C292/S									3725		SA520067	
203392	1S 215-22	296.1.340	D296/D												
203698	1S 270-27	290.0.480	D290/D												
203715	1T 300-37	278.4.452	D278/S	W01-M58-6366	1T 17 BS-6	1 DK 22 E8		4004 NP03		1R 11-713		34004 KPP		SA520090C	
203833	1S 323-36	298.0.515	D298/B							8314					
203878	1T 19E-2	277.4.506	D277	W01-M58-6334	1T 19 F-11	1 D 28 B7		811 MB 3 st		1R 14-718		3811 K		SA520081C	
203933	1S 270-26	290.0.440	D290/C												
203976	1S 270-20V	290.2.340	D290/E												
203992	1S 270-20V	290.2.341	D290/E												
204124/93800	1T 323-40	278.4.511	D278/H	W01-M58-7548	1T 15 M-9	1 DK 23L-27		4159 NP03		1R 12-701		34159-10 KPP			
204151(ex 206796)	1S 270-25	290.1.420	D290/B												
204158(ex 206790)	1S 270-23	290.1.394	D290/B												
204159(ex 206791)	1S 270-23	290.1.395	D290/B												
204161(ex 206792)	1S 270-23	290.1.396	D290/B												
204162(ex 206793)	1S 270-23	290.1.397	D290/B												
204250	1SC 250-29BB	301.0.330	C301							9012					
204268	1S 270-30	290.0.555	D290/F												
204290	1S 323-40	298.0.620	D298												
204357	1T 19E-1	277.2.420	D277/B	W01-M58-6344	1T 19 L-7										
204371 (ex 93762)	1T 19 E-2	277.2.500	D2772F	W01-M58-6361	1T 19 L-11	1 DK 28 B7				1R 14-706		391318 K		SA520021C	
204413	322 BB	271.3.298	T271/S									3B-300 / 115002		/	
204427	1S 290-23V	286.0.420	D286												
204450	322 BB	271.3.298/2	T271/S												
204460	1S 290-23V	286.2.422	D286												

I nominativi dei costruttori e i relativi riferimenti originali citati nel presente catalogo sono riportati a puro titolo indicativo. I nostri prodotti non sono originali ma con essi intercambiabili.
The name of manufacturers and the o.e. references mentioned in this catalogue are given for cross-reference purposes only. Our products are not original but interchangeable with.



TABELLA COMPARATIVA MOLLE AD ARIA da codici CF GOMMA
AIR SPRINGS CROSS-REFERENCE LIST from CF GOMMA codes

CF Gamma		GART			Firestone		Phoenix		Contitech		Goodyear		Airtech		Sabo	
Codice - Code	Tipo - Type	Codice - Code	Tipo - Type	Codice - Code	Tipo - Type	Codice - Code	Tipo - Type	Codice - Code	Codice - Code	Codice - Code	Codice - Code	Codice - Code	Codice - Code	Codice - Code	Codice - Code	Codice - Code
204461	1S 290-23V	286.2.423	D286													
204466	1TC 300-36	293.0.511	C293	W01-M58-8620	1T 17 D-8.3	1 DK 21		941 MB		1R 11-700		3941		SA520028		
204493	1S 290-23V	286.2.420	D286													
204494	1S 290-23V	286.2.421	D286													
204530	1TC 360-45	292.0.531	C292	W01-M58-8978	1T 66 D-10.8	1 DK 32		881 MB		1R 14-708		3881		SA520029		
204537	1S 270-23	290.1.398	D290/B													
204538	1S 270-23	290.1.399	D290/B													
204676	1T 19 E-2	277.4.505	D277	W01-M58-6348	1T 19 L-11	1 D 28 B10		4023 NP03		1R 14-729		34023 K		SA520059C		
204759	1T 19 E-3	287.2.580	D287/B													
204772	1S 215-24	296.0.375	D296/B													
205074	1S 290-30V	286.0.550	D286/B													
205170	1TC 300-36	293.2.510	C293	W01-M58-8619	1T 17 D-8.3	1 DK 21-1		941 MB		1R 11-702 / 762		3941 K		SA520028C		
205171	1TC 360-45	292.2.531	C292													
205456	1T 19 E-1	277.4.423	D277/B	W01-M58-6338	1T 19 L-7	1 D 28 A10		4810 NP05		1R 14-730		32918 K		SA520146C		
205536	1TC 300-30	293.0.411	C293/A	W01-M58-8613	1T 17 D-4.3	1 DK 21 K		940 MB		1R 11-703		3940		SA520034		
205537	1TC 360-40	292.0.461	C292/A	W01-M58-8601	1T 66 D-7.0	1 DK 32 K		4881 NP02		1R 14-701		34881		SA520030		
205598	1TC 300-38	294.2.450	C294	W01-M58-7074	1T 15 MPW-7	1 DK 21 A31		4157 NP09		1R 11-106		39002-A3 KPP		SA520036C		
205598	1TC 300-38	294.0.451	C294	W01-M58-7074	1T 15 MPW-7	1 DK 21 A3		4157 NP05				39002-A3		/		
205800	1TC 360-45	292.2.530	C292	W01-M58-8966	1T 66 D-10.8	1 DK 32-1		881 MB		1R 14-712		3881-01 K		SA520029C		
205868	1T 19 E-1	277.4.424	D277/B													
206201	1T 19 E-93	287.1.606	D287/H	W01-M58-9881	1T 19 L-14	1 D 28 H16		4913 NP02		1R 14-753		34913 K		SA520045C		
206333 / 207713	1T 19 E-2L	287.4.601	D287/C					912 NP01		1R 14-728		32926 K		SA520132C		
206340 (ex 204677)	1T 300-37	278.4.454	D278/S	W01-M58-6367	1T 17 BS-6	1 DK 22 E9		4022 NP03		1R 11-714		34022 KPP		SA520095C		
206356	1TC 300-36	293.2.512	C293	W01-M58-8619	1T 17 D-8.3	1 DK 21-2		941 MB		1R 11-743		3941-01 KPP		SA520088C		
206357	1TC 360-45	292.2.532	C292	W01-M58-8967	1T 66 D-10.8	1 DK 32-2		881 MB		1R 14-748		3881-01 KPP		SA520087C		
206506	1T 329-40	278.0.511	D278/H					4159 NP05		1R 12-761		34159		SA520117		
206585	1T 300-37	278.1.455	D278/S	W01-M58-8612	1T 17 BS-6			4022 NP05				32619 KPP		SA520131C		
206657	20	291.2.203/1	T291/2													
206660	1S 270-23V	290.2.390	D290/B													
206661	1S 270-23V	290.2.391	D290/B													
206684	1TS 270-23	290.1.392	D290/BR	W01-M58-8665	1T 15 LRN-4.5											
206685	1TS 270-23	290.1.393	D290/BR	W01-M58-8660	1T 15 LRN-4.5											

I nominativi dei costruttori e i relativi riferimenti originali citati nel presente catalogo sono riportati a puro titolo indicativo. I nostri prodotti non sono originali ma con essi intercambiabili.
The name of manufacturers and the o.e. references mentioned in this catalogue are given for cross-reference purposes only. Our products are not original but interchangeable with.



TABELLA COMPARATIVA MOLLE AD ARIA da codici CF GOMMA
AIR SPRINGS CROSS-REFERENCE LIST from CF GOMMA codes

CF Gamma		GART		Firestone		Phoenix		Contitech		Goodyear		Airttech		Sabro	
Codice - Code	Tipo - Type	Codice - Code	Tipo - Type	Codice - Code	Tipo - Type	Codice - Code	Tipo - Type	Codice - Code	Tipo - Type	Codice - Code	Tipo - Type	Codice - Code	Tipo - Type	Codice - Code	Tipo - Type
206686	1TS 270-23	290.1.390	D290/BR	W01-M58-8663	1T 15 LRN-4.5										
206687	1TS 270-23	290.1.391	D290/BR	W01-M58-8662	1T 15 LRN-4.5										
206778	1TS 300-28	293.0.461	C293/V					4713 N		1R 12-763		34713		SA520072	
206779	1T 19 E4	287.1.600	D287/C	W01-M58-8786	1T 19 L-14		1 DK 28 F4	4912 NP07		1R 13-711		34912 K		SA520060C	
206780	1T 19 E4	287.0.601	D287/C					4912 NP08				34912		SA520060	
206781	1VSC 285-30	304.1.444	C304					4390 NP04				34390-04 K			
206782	1VSC 285-30	304.0.440	C304	W01-M58-0904	1R 7Z 440-290-B		1 KF 21-1 NP	4390 N1		9507		34390-01		SA520093	
206783	1VSC 285-30	304.1.443	C304					4390 NP03				34390-03 K			
206784	1VSC 285-30	304.0.441	C304	W01-M58-0905	1R 7Z 440-290-C		1 KF 21-2 NP	4390 N2		9508		34390-02			
206785	1VSC 300-26	299.1.461	C299/A	W01-M58-8521	1R 7Z 460-305-A			4757 NP01 / NP21		9519		34757-01 K		SA520177C	
206786	1VSC 300-26	299.1.460	C299/A	W01-M58-8522	1R 7Z 460-305-B			4757 NP02/NP09/NP29		9520		34757-02 K		SA520178C	
206797	20	291.2.200	T291/2	W01-M58-6910 / 6887	20		2 B 12 R	FD 200-19 1/4 M10		2B 9-223		2B-220 / 113001		SA520079	
207065	20L	291.2.263	T291/2B	W01-M58-6891	20-2		2 B 12 RA-3	FD 200-25 P02		2B 9-701					
207170	1TS 270-23	290.0.394	D290/BR												
207171	1TS 270-23	290.0.395	D290/BR												
207172	1TS 270-23	290.0.392	D290/BR												
207173	1TS 270-23	290.0.393	D290/BR												
207308	1TC 300-30K	293.2.412	C293/A	W01-M58-8595	1T 17 D-4.3		1 DK 21 K-2	940 MB		1R 11-752		3940 KPP		SA520129C	
207309	1TC 360-40K	292.2.462	C292/A	W01-M58-8666	1T 66 D-7.0		1 DK 32 K-2	4881 MB		1R 14-757		34881-01 KPP		SA520130C	
207463	1T 300-40	294.2.451	C294	W01-M58-6297	1T 15 MPW-7		1 DK 21 A4	4157 NP04		1R 11-111		39002-A8 KPP		SA520037C	
207701	1TS 260-32	289.1.510	C289/M	W01-M58-9880	1T 17 TWR-8			4882 N1 P05				34882 K		SA520187C	
207702	1TS 290-28	304.1.510	C304/M4	W01-M58-9879	1T 17 JR-7.2			4884 N1 P06				34884 K		SA520189C	
207710	1TC 300-30	293.2.415	C293/A					4960							
207711	1TC 300-30	293.0.412	C293/A				1 D 21 K-3	4960 NP02		1R 11-801		34960		SA520047	
207714	1T 323-40 TYPE	278.4.517	D278/H1												
207717	1T 300-37	278.4.456	D278/S												
207718	1T 300-37	278.1.454	D278/S												
207719	1T 300-37	278.1.453	D278/S												
207722	1T 300-37	278.1.452	D278/S												
207726	1SC 285-30	289.0.460	C289/G												
207732	1T 19 E-2	277.4.505/1	D277												
207733	1T 19 E-1	277.4.424/1	D277/B												

I nominativi dei costruttori e i relativi riferimenti originali citati nel presente catalogo sono riportati a puro titolo indicativo. I nostri prodotti non sono originali ma con essi intercambiabili.
The name of manufacturers and the o.e. references mentioned in this catalogue are given for cross-reference purposes only. Our products are not original but interchangeable with.



**TABELLA COMPARATIVA MOLLE AD ARIA da codici CF GOMMA
AIR SPRINGS CROSS-REFERENCE LIST from CF GOMMA codes**

CF Gamma		GART		Firestone		Phoenix		Contitech		Goodyear		Airtech		Sabo	
Codice - Code	Tipo - Type	Codice - Code	Tipo - Type	Codice - Code	Tipo - Type	Codice - Code	Tipo - Type	Codice - Code	Tipo - Type	Codice - Code	Tipo - Type	Codice - Code	Tipo - Type	Codice - Code	Tipo - Type
207734	1T 19 E-2	277.4.505/2	D277												
207735	1T 19 E-2	277.1.505	D277												
207736	1T 19 E-2L	287.4.601/1	D287/C												
207737	1T 19 E-2L	287.1.604	D287/C												
207759	1TS 290-28	304.0.511	C304/M4					4884 N1 P01	1R 11-820	34884	SA520189				
207760	1TS 260-32	289.0.512	C289/M					4882 N1 P01		34882	SA520187				
207761	1TS 290-28	304.0.513	C304/M3					4883 N1 P01	1R 11-804	34883	SA520188				
207762	1TS 260-20	289.0.411	C289/M1					4885 N1 P01							
207764	1TS 260-20	289.1.410	C289/M1					4885 N1 P02							
207765	1VSC 285-30	304.1.440	C304	W01-M58-8514	1R 7Z 440-290-B	1 KF 21-1		4390 NP01 / NP21	9505	34390-01 K	SA520093C				
207766	1VSC 285-30	304.1.441	C304	W01-M58-8513	1R 7Z 440-290-C	1 KF 21-2		4390 NP02 / NP22	9506	34390-02 K	SA520098C				
207769	1T 19 E4	287.1.603	D287/C					4912 NP10		34912-10 K	SA520241C				
207770	1T 19 E3	287.1.540	D287/E					4911 NP03	1R 13-714	34911 K	SA520075C				
207771	1T 19 E3	287.1.541	D287/E					4911 NP04		34911-04 K					
207772	1T 19 E-83	287.0.603	D287/H	W01-095-0365	1T 19 F-14			4913 NP04	1R 14-755	34913	SA520045				
207773	20	291.2.203	T291/2	W01-M58-7894	20F	2 B 12 R3		FD 200-19 P04	2B 9-700	2B-220-3 / 113002	SA520106				
207774	1TS 300-28	278.1.355	D278/V1					4420 NP01							
207775	1TS 300-28	293.1.460	C293/V	W01-M58-9706		1 DF 22 C1		4713 NP 02	1R 12-762	34713 K	SA520072C				
207776	20L	291.2.260	T291/2B	W01-M68-7394 / 7679	20-2	2 B 12 RA-10		FD 200-25 1/4 M10	2B 9-269						

I nominativi dei costruttori e i relativi riferimenti originali citati nel presente catalogo sono riportati a puro titolo indicativo. I nostri prodotti non sono originali ma con essi intercambiabili.
The name of manufacturers and the o.e. references mentioned in this catalogue are given for cross-reference purposes only. Our products are not original but interchangeable with.



TABELLA COMPARATIVA MOLLE AD ARIA da codici FIRESTONE
AIR SPRINGS CROSS-REFERENCE LIST from FIRESTONE codes

Firestone		GART		CF Gamma		Phoenix		Contitech		Goodyear		Airtech		Sabo	
Codice - Code	Tipo - Type	Codice - Code	Tipo Type	Codice - Code	Tipo - Type	Codice - Code	Tipo - Code	Codice - Code	Codice - Code	Codice - Code	Codice - Code	Codice - Code	Codice - Code	Codice - Code	Codice - Code
W01-095-0021	1R1C390-310	297.0.390	D297	91016	1S 310-28-RF	1 E 25	661 N	8018	3661	SA520009					
W01-095-0118	1R 1A 390 295	276.0.390	D276/B	92574	1S 285-24	1 E 21	644 N	8017	3644	SA520002					
W01-095-0121	1R 1B 390-270	290.0.390	D290/B	97619	1S 270-23	1 E 21-6	943 N	9009	3944	SA520035					
W01-095-0189	1R 1A 260 285	276.0.260	D276/D	88809	1S 285-18		727 N / 728 N	9001	3943	SA520026					
W01-095-0191 / 0419	1R2D460 360 / 1R2D470 360	292.0.450	C292/D	92575	1SC 360-34	1 F 32A / 32A-2	719 N	8117	3727 / 3728	SA520084 / A520085					
W01-095-0192	1R2D 530 360	292.0.520	C292/E	92593	1SC 360-43	1 F 32 B	720 N	8118	3719	SA520083					
W01-095-0195	1R 2A 460-295	299.0.450	C299	88802	1SC 290-30	1 F 21	945 N	9008	3720	SA520044					
W01-095-0197	1R 1A 415 285	276.0.420	D276	97555	1S 285-25	1 E 21 C	944 N	9013	3945	SA520003					
W01-095-0198	1R 1A 370 285	276.0.370	D276/C	88786	1S 285-22		662 N / 762 N	8012	3944	SA520035					
W01-095-0207 / 0190	1R1D355-355 / 1R2D390-360	292.0.380	C292/C	92594	1SC 360-30	1 E 32	768 N	9007 / 9010	3662 / 3762	SA520046 / A520048					
W01-095-0213	1R2A 380 330	302.0.385	C302/A			1 E 27	620 N		3768	SA520043					
W01-095-0219	280	272.0.199	T272/N			2 B 15 R	782 N								
W01-095-0295	1R 1B 415-270	290.0.420	D290	97608	1S 270-25	1 E 21 E	4913 NP04	1R 14-755	3782	SA520065					
W01-095-0365	1T 19 F-14	287.0.603	D287/H	207772	1T 19 E-93		1884 N1 / 1885 N1	9003	34913	SA520045					
W01-095-0429	1R 2A 445 280	289.0.450	C289/C	202265	1SC 270-30	1 F 20 B1	882 N1		31885	SA520031					
W01-095-0435	1R4R 465 260	289.0.400	C289/D	97042	1SC 250-28	1 F 16	1421 N	9072	31421	SA520092					
W01-095-0472	1R 2A 490-305	299.0.490	C299/E				4156 NP06	1R 12-707	34156 KPP	SA520089C					
W01-358-9361	1T 15 M-6	278.4.421	D278/G	97306 / 207777	1T 323-32	1 DK 21 A2		1R 12-603							
W01-358-9780	1T 15 ZR-6	278.1.430	D278/R			1 DK 23 K-9780		1R 12-702							
W01-379-9091 / 8859	1T 15 M-9	278.2.511	D278/H	202302 / 96978	1T 323-40	1 DK 23L-25	4159 NP07	34159-05 K		SA520128C					
W01-M58-0756	1T 17 BS-6	278.0.452	D278/S				4022 NP02	1R 11-709	34022	SA520055					
W01-M58-0776	1T 17 AR 4.5	302.0.376	C302			1 DF 25-1	836 M	1R 12-700	3836	SA520061A					
W01-M58-0777	1T 17 AR 4.5	302.0.376/2	C302			1 DF 25-3	836 M2	1R 12-710	3836-02	SA520040					
W01-M58-0904	1R 7Z 440-290-B	304.0.440	C304	206782	1VSC 285-30	1 KF 21-1 NP	4390 N1	9507	34390-01	SA520093					
W01-M58-0905	1R 7Z 440-290-C	304.0.441	C304	206784	1VSC 285-30	1 KF 21-2 NP	4390 N2	9508	34390-02						
W01-M58-0909	1R 7Z 460-305-A	299.0.461	C299/A				4757 N1	9517							
W01-M58-0910	1R 7Z 460-305-B	299.0.460	C299/A				4757 N2	9518							
W01-M58-6238	1T 15 MPW-9	294.1.501	C294/HS												
W01-M58-6251	1T 15 LP-3	306.2.320	D306						36251 K	SA520185C					
W01-M58-6257	1T 15 MP-9	278.0.531	D278/HS				4158 NP02		34158	SA520091					
W01-M58-6287	1T 15 MPW-9	294.1.502	C294/HS												
W01-M58-6289	1T 15 M-9	278.2.512	D278/H	96871	1T 323-40			1R 12-703	391209 K	SA520023C					

I nominativi dei costruttori e i relativi riferimenti originali citati nel presente catalogo sono riportati a puro titolo indicativo. I nostri prodotti non sono originali ma con essi intercambiabili.

The names of manufacturers and the o.e. references mentioned in this catalogue are given for cross-reference purposes only. Our products are not original but interchangeable with.



**TABELLA COMPARATIVA MOLLE AD ARIA da codici FIRESTONE
AIR SPRINGS CROSS-REFERENCE LIST from FIRESTONE codes**

Firestone			GART			CF Gomma			Phoenix			Contitech			Goodyear			Airtech			Sabo		
Codice - Code	Tipo - Type	Codice - Code	Tipo - Type	Codice - Code	Tipo - Type	Codice - Code	Tipo - Type	Codice - Code	Tipo - Type	Codice - Code	Tipo - Type	Codice - Code	Tipo - Type	Codice - Code	Tipo - Type	Codice - Code	Tipo - Type	Codice - Code	Tipo - Type	Codice - Code	Tipo - Type	Codice - Code	
W01-M58-6297	1T 15 MPW-7	294.2.451	C294	207463	1T 300-40	1 DK 21 A4	4157 NP04	1R 11-111	39002-A8 KPP	SA520037C													
W01-M58-6315	1T 15 MPW-7	294.1.450	C294		1 DK 20 A51	4157 NP10	4157 NP10	1R 11-772	39002-A3-01 KPP	SA520127C													
W01-M58-6317	1T 15 MPW-7	294.1.452	C294		1 DK 20 C-2	4157 NP08	4157 NP08	1R 11-773	39002-A3-08 KPP	SA520181C													
W01-M58-6318	1T 15 MPW-9	294.1.500	C294/HS																				
W01-M58-6334	1T 19 F-11	277.4.506	D277	203878	1T 19 E-2	1 D 28 B7	811 MB 3 st	1R 14-718	3811 K	SA520081C													
W01-M58-6338	1T 19 L-7	277.4.423	D277/B	205456	1T 19 E-1	1 D 28 A10	4810 NP05	1R 14-730	32918 K	SA520146C													
W01-M58-6344	1T 19 L-7	277.2.420	D277/B	204957	1T 19 E-1																		
W01-M58-6345 / 8775	1T 19 L-7	277.4.420	D277/B	87413/1	1T 19 E-1	1 D 28 A2	810 MB	1R 14-716	3810 K	SA520010C													
W01-M58-6348	1T 19 L-11	277.4.505	D277	204676	1T 19 E-2	1 D 28 B10	4023 NP03	1R 14-729	34023 K	SA520059C													
W01-M58-6360	1T 19 L-11	277.4.501	D277/C																				
W01-M58-6361	1T 19 L-11	277.2.500	D277/2F	204371 (ex 93762)	1T 19 E-2	1 DK 28 B7		1R 14-706	391318 K	SA520021C													
W01-M58-6363	1T 19 L-11	277.2.504	D277/2F	97730	1T 19 E-2				391318 K/1	SA520021C/1													
W01-M58-6364 / 6339	1T 19 L-11	277.4.507	D277	87408	1T 19 E-2	1 D 28 B2	813 MB	1R 14-705 (061)	3813 K	SA520070C													
W01-M58-6364 / 6339	1T 19 L-11	277.4.500	D277	87408	1T 19 E-2	1 D 28 B2	813 MB	1R 14-705 (061)	3813 K	SA520070C													
W01-M58-6366	1T 17 BS-6	278.4.452	D278/S	203715	1T 300-37	1 DK 22 E8	4004 NP03	1R 11-713	34004 KPP	SA520090C													
W01-M58-6367	1T 17 BS-6	278.4.454	D278/S	206340 (ex 204677)	1T 300-37	1 DK 22 E9	4022 NP03	1R 11-714	34022 KPP	SA520095C													
W01-M58-6891	20-2	291.2.263	T291/2B	207065	20L	2 B 12 RA-3	FD 200-25 P02	2B 9-701															
W01-M58-6910 / 6887	20	291.2.200	T291/2	206797	20	2 B 12 R	FD 200-19 1/4 M10	2B 9-223	2B-220 / 113001	SA520079													
W01-M58-6988	26	281.2.190	T281	84181	26	2 B 07 N	603 N																
W01-M58-6989	21- D2	274.2.270	T274/C	97300	21A BR	2 B 34 RA																	
W01-M58-6990	20	291.2.201	T291/2	86600	20			8325															
W01-M58-7074	1T 15 MPW-7	294.0.451	C294	205598	1TC 300-38	1 DK 21 A3	4157 NP05		39002-A3	/													
W01-M58-7074	1T 15 MPW-7	294.2.450	C294	205598	1TC 300-38	1 DK 21 A31	4157 NP09	1R 11-106	39002-A3 KPP	SA520036C													
W01-M58-7313	1T 15 LP-6	306.1.420	D306/A																				
W01-M58-7358	1T 19 L-11	287.4.520	D287	97764	Airspring E2	1 D 28 B9	4813 NP07	1R 14-727	34813 K	SA520056C													
W01-M58-7370	1T 19 L-11	287.4.521	D287					1R 14-721															
W01-M58-7380 / 8765	1T 19 L-12	287.4.580	D287/B	97343	1T 19 E-3	1 D 28 C12	912 NP02	1R 13-734	391303 K	SA520012C													
W01-M58-7385 / 8502	1 T19 L14	287.4.600	D287/C		20L	1 D 28 D2	912 NP02		391314 K	SA520020C													
W01-M58-7394 / 7679	20-2	291.2.260	T291/2B	207776	20L	2 B 12 RA-10	FD 200-25 1/4 M10	2B 9-269															
W01-M58-7502	1T 19 L 11	287.4.512	D287/A			1 D 28 B4		1R 14-709															
W01-M58-7524	22 D	271.2.200	T271/2	88544	22	2 B 22 R																	
W01-M58-7526	313 D	274.3.300	T274/3	88110	321																		

I nominativi dei costruttori e i relativi riferimenti originali citati nel presente catalogo sono riportati a puro titolo indicativo. I nostri prodotti non sono originali ma con essi intercambiabili.
The name of manufacturers and the o.e. references mentioned in this catalogue are given for cross-reference purposes only. Our products are not original but interchangeable with.



**TABELLA COMPARATIVA MOLLE AD ARIA da codici FIRESTONE
AIR SPRINGS CROSS-REFERENCE LIST from FIRESTONE codes**

Firestone		GART		CF Gamma		Phoenix		Contitech		Goodyear		Airtech		Sabo	
Codice - Code	Tipo - Type	Codice - Code	Tipo Type	Codice - Code	Tipo - Type	Codice - Code	Codice - Code	Codice - Code	Codice - Code	Codice - Code	Codice - Code	Codice - Code	Codice - Code	Codice - Code	Codice - Code
W01-M58-7527	233-D2	274.2.310	T274/B	92154	21B BR	1 DK 23L-27	4159 NP03	1R 12-701				34159-10 KPP			
W01-M58-7548	1T 15 M-9	278.4.511	D278/H	204124/93800	1T 323-40							2B-370Hyd / 113361			SA520137
W01-M58-7710	233 C	274.2.210	T274	89457	21 BR							2B-220-3 / 113002			SA520106
W01-M58-7894	20F	291.2.203	T291/2	207773	20	2 B 12 R3	FD 200-19 P04	2B 9-700							
W01-M58-7992	38 C	271.3.290	T271	89413	322 BR										
W01-M58-7992	38 C	271.3.293	T271	87987	322							3B-300Hyd / 115005			SA520136
W01-M58-8106	1T 19 L-12	287.4.540	D287/E			1 D 28 F-1	4028 NP02	1R 14-783				34028 K			
W01-M58-8185	1T 15 MPW-9	278.1.530/1	D278/HS			1 DK 20 B1	4158 NP03	1R 12-749				34158 KPP			SA520091C
W01-M58-8185	1T 15 MPW-9	278.1.530	D278/HS			1 DK 20 B1	4158 NP03	1R 12-749				34158 KPP			SA520091C
W01-M58-8186	1T 15 MPW-7	294.1.451	C294			1 DK 20 A1	4157 NP06	1R 11-764				38186 KPP			SA520165C
W01-M58-8192	1T 15 VR-3	278.2.300	D278/NA					1R 13-746				330301 K			SA520198C
W01-M58-8193	1T 15 VPR-3	278.2.330	D278/N					1R 12-809				330302 K			SA520205C
W01-M58-8472	1T 15 LRN-6	294.1.430	C294/V			1 DF 20 D-1	6605 NP01	1R 11-805				37803 K			SA520182C
W01-M58-8473	1T 15 UR-6	295.1.400	C295/VA				6607 NP01					36418 K			SA520208C
W01-M58-8474	1T 15 UR-9	295.1.465	C295/V				6608 NP01	1R 10-704				36416 K			SA520175C
W01-M58-8477	1T 15 LRN-3	294.1.370	C294/VA			1 DF 20 E-1	6606 NP01	1R 11-848				37804 K			SA520215C
W01-M58-8513	1R 7Z 440-290-C	304.1.441	C304	207766	1VSC 285-30	1 KF 21-2	4390 NP02 / NP22	9506				34390-02 K			SA520098C
W01-M58-8514	1R 7Z 440-290-B	304.1.440	C304	207765	1VSC 285-30	1 KF 21-1	4390 NP01 / NP21	9505				34390-01 K			SA520093C
W01-M58-8521	1R 7Z 460-305-A	298.1.461	C299/A	206785	1VSC 300-26		4757 NP01 / NP21	9519				34757-01 K			SA520177C
W01-M58-8522	1R 7Z 460-305-B	298.1.460	C299/A	206786	1VSC 300-26		4757 NP02/NP09/NP29	9520				34757-02 K			SA520178C
W01-M58-8595	1T 17 D-4.3	293.2.412	C293/A	207308	1TC 300-30K	1 DK 21 K-2	940 MB	1R 11-752				3940 KPP			SA520129C
W01-M58-8601	1T 66 D-7.0	292.0.461	C292/A	205537	1TC 360-40	1 DK 32 K	4881 NP02	1R 14-701				34881			SA520030
W01-M58-8602	1T 66 D-7.0	292.2.460	C292/A			1 DK 32 K-1	4881 MB	1R 14-724				34881-01 K			SA520030C
W01-M58-8609	1T 17 D-4.3	293.2.410	C293/A			1 DK 21 K-1	940 MB	1R 11-763				3940 K			SA520034C
W01-M58-8610	1T 66 D-10.8	292.1.533	C292/S			1 DF 32	725 NP03	1R 14-756				3725-01 K			SA520125C
W01-M58-8611	1T 66 F-13.5	292.0.601	C292/B			1 DK 32 L	942 MB	1R 14-700				3942			SA520068
W01-M58-8612	1T 17 BS-6	278.1.455	D278/S	206585	1T 300-37		4022 NP05					32619 KPP			SA520131C
W01-M58-8613	1T 17 D-4.3	293.0.411	C293/A	205536	1TC 300-30	1 DK 21 K	940 MB	1R 11-703				3940			SA520034
W01-M58-8619	1T 17 D-8.3	293.2.510	C293	205170	1TC 300-36	1 DK 21-1	941 MB	1R 11-702 / 762				3941 K			SA520028C
W01-M58-8619	1T 17 D-8.3	293.2.512	C293	206356	1TC 300-36	1 DK 21-2	941 MB	1R 11-743				3941-01 KPP			SA520088C
W01-M58-8620	1T 17 D-8.3	293.0.511	C293	204466	1TC 300-36	1 DK 21	941 MB	1R 11-700				3941			SA520028
W01-M58-8621	1T 17 D-11.8	293.0.611	C293/B				951 MB	1R 11-704				3951			SA520063

I nominativi dei costruttori e i relativi riferimenti originali citati nel presente catalogo sono riportati a puro titolo indicativo. I nostri prodotti non sono originali ma con essi intercambiabili.
The names of manufacturers and the o.e. references mentioned in this catalogue are given for cross-reference purposes only. Our products are not original but interchangeable with.



**TABELLA COMPARATIVA MOLLE AD ARIA da codici FIRESTONE
AIR SPRINGS CROSS-REFERENCE LIST from FIRESTONE codes**

Firestone		GART		CF Gomma		Phoenix		Contitech		Goodyear		Airtech		Sabo	
Codice - Code	Tipo - Type	Codice - Code	Tipo Type	Codice - Code	Tipo - Type	Codice - Code	Phoenix - Code	Codice - Code	Contitech - Code	Codice - Code	Goodyear - Code	Codice - Code	Airtech - Code	Codice - Code	Sabo - Code
W01-M58-8633	1T 17 HR-8	287.1.480	D287/SC										34933 K		
W01-M58-8653	1T 15 UR-9	295.1.475	C295/SC												
W01-M58-8660	1T 15 LRN-4.5	290.1.393	D290/BR	206685	1TS 270-23										
W01-M58-8662	1T 15 LRN-4.5	290.1.391	D290/BR	206687	1TS 270-23										
W01-M58-8663	1T 15 LRN-4.5	290.1.390	D290/BR	206686	1TS 270-23										
W01-M58-8665	1T 15 LRN-4.5	290.1.392	D290/BR	206684	1TS 270-23										
W01-M58-8666	1T 66 D-7.0	292.2.462	C292/A	207509	1TC 360-40K	1 DK 32 K-2		4881 MB		1R 14-757		34881-01 KPP		SA520130C	
W01-M58-8721	1T 17 AR 4.5	302.1.375/2	C302			1 DF 25-13		836 M2 K1		1R 12-711		3836-02K		SA520069C	
W01-M58-8722	1T 17 AR 4.5	302.1.375	C302			1 DF 25-11		836 MK1		1R 12-712		3836 K		SA520061C	
W01-M58-8747	1T 17 B-11	278.4.535	D278/D			1 DK 25-1				1R 13-150		30081 K			
W01-M58-8762	1T 19 L-14	287.4.581	D287/B	201840	1T 19 E-3	1 DK 28 D3						391304 K		SA520019C	
W01-M58-8772	1T 19 L-7	277.2.421	D277/B	96884	1T 19 E-1	1 DK 28 A7						36884 K		SA520162C	
W01-M58-8786	1T 19 L-14	287.1.600	D287/C	206779	1T 19 E4	1 DK 28 F4		4912 NP07		1R 13-711		34912 K		SA520060C	
W01-M58-8794	1T 19 L-11	277.2.503	D277	96885	1T 19 E-2							36885 K		SA520163C	
W01-M58-8795	1T 19 L-11	287.2.510	D287/A	97039	Airspring E2					1R 14-707					
W01-M58-8840	1T 15 MPW-7	294.2.450/1	C294			1 DK 21 A3									
W01-M58-8966	1T 66 D-10.8	292.2.530	C292	205800	1TC 360-45	1 DK 32-1		881 MB		1R 14-712		3881-01 K		SA520029C	
W01-M58-8967	1T 66 D-10.8	292.2.532	C292	206357	1TC 360-45	1 DK 32-2		881 MB		1R 14-748		3881-01 KPP		SA520087C	
W01-M58-8969	1T 66 E-10.8	292.1.534	C292/S			1 DF 32		725 NP02		1R 14-747		3725 K		SA520067C	
W01-M58-8978	1T 66 D-10.8	292.0.531	C292	204530	1TC 360-45	1 DK 32		881 MB		1R 14-708		3881		SA520029	
W01-M58-9131	1T 15 M-9	278.1.510	D278/H	200751	1T 323-40	1 DK 23 L-9131		4159 NP09		1R 12-721		34159-02 KPP		SA520094C	
W01-M58-9706		293.1.460	C293/V	207775	1TS 300-28	1 DF 22 C1		4713 NP 02		1R 12-762		34713 K		SA520072C	
W01-M58-9879	1T 17 JR-7.2	304.1.510	C304/M4	207702	1TS 290-28			4884 N1 P06				34884 K		SA520189C	
W01-M58-9880	1T 17 TWR-8	289.1.510	C289/M	207701	1TS 260-32			4882 N1 P05				34882 K		SA520187C	
W01-M58-9881	1T 19 L-14	287.1.606	D287/H	206201	1T 19 E-93	1 D 28 HI16		4913 NP02		1R 14-753		34913 K		SA520045C	
W01-F58-4089	271	274.0.310	T274/B	97141 (ex 89749)	21 B										
W01-F88(M58)-8608	1T 17 DJ-J	294.2.460	C294/R										38608 KPP		/
W01-F88-6268	1T 15 M-6	278.4.421/1	D278/G												
W01-F88-8849	1T 15 M-9	278.4.511/1	D278/H												

I nominativi dei costruttori e i relativi riferimenti originali citati nel presente catalogo sono riportati a puro titolo indicativo. I nostri prodotti non sono originali ma con essi intercambiabili.
The name of manufacturers and the o.e. references mentioned in this catalogue are given for cross-reference purposes only. Our products are not original but interchangeable with.



**TABELLA COMPARATIVA MOLLE AD ARIA da codici PHOENIX
AIR SPRINGS CROSS-REFERENCE LIST from PHOENIX codes**

Phoenix		GART		CF Gomma		Firestone		Comtitech		Goodyear		Airtech		Sabo	
Codice - Code	Tipo - Type	Codice - Code	Tipo - Type	Codice - Code	Tipo - Type	Codice - Code	Tipo - Type	Codice - Code	Tipo - Type	Codice - Code	Tipo - Type	Codice - Code	Tipo - Type	Codice - Code	Tipo - Type
1 D 21 K-3	C293/A	293.0.412	207711	1TC 300-30						4960 NP02	1R 11-801	34960		SA520047	
1 D 28 A10	D277/B	277.4.423	205456	1T 19 E-1		W01-M58-6338	1T 19 L-7			4810 NP05	1R 14-730	32918 K		SA520146C	
1 D 28 A13	D277/B	277.2.422													
1 D 28 A2	D277/B	277.4.420	87413/1	1T 19 E-1		W01-M58-6345 / 8775	1T 19 L-7			810 MB	1R 14-716	3810 K		SA520010C	
1 D 28 B10	D277	277.4.505	204676	1T 19 E-2		W01-M58-6348	1T 19 L-11			4023 NP03	1R 14-729	34023 K		SA520059C	
1 D 28 B2	D277	277.4.507	87408	1T 19 E-2		W01-M58-6364 / 6339	1T 19 L-11			813 MB	1R 14-705 (061)	3813 K		SA520070C	
1 D 28 B2	D277	277.4.500	87408	1T 19 E-2		W01-M58-6364 / 6339	1T 19 L-11			813 MB	1R 14-705 (061)	3813 K		SA520070C	
1 D 28 B4	D287/A	287.4.512				W01-M58-7502	1T 19L 11								
1 D 28 B7	D277	277.4.506	203878	1T 19E-2		W01-M58-6334	1T 19 F-11			811 MB 3 st	1R 14-718	3811 K		SA520081C	
1 D 28 B9	D287	287.4.520	97764	Airspring E2		W01-M58-7358	1T 19 L-11			4813 NP07	1R 14-727	34813 K		SA520056C	
1 D 28 C12	D287/B	287.4.580	97943	1T 19 E-3		W01-M58-7380 / 8765	1T 19 L-12				1R 13-734	391303 K		SA520012C	
1 D 28 D2	D287/C	287.4.600				W01-M58-7385 / 8502	1T 19 L14			912 NP02		391314 K		SA520020C	
1 D 28 F-1	D287/E	287.4.540				W01-M58-8106	1T 19 L-12			4028 NP02	1R 14-783	34028 K		SA520230C	
1 D 28 F3	D277/D	277.2.520													
1 D 28 H16	D287/H	287.1.606	206201	1T 19 E-93		W01-M58-9881	1T 19 L-14			4913 NP02	1R 14-753	34913 K		SA520045C	
1 DF 20 D-1	C294/V	294.1.430				W01-M58-8472	1T 15 LRN-6			6605 NP01	1R 11-805	37803 K		SA520182C	
1 DF 20 E-1	C294/VA	294.1.370				W01-M58-8477	1T 15 LRN-3			6606 NP01	1R 11-848	37804 K		SA520215C	
1 DF 22 C1	C293/V	293.1.460	207775	1TS 300-28		W01-M58-9706				4713 NP02	1R 12-762	34713 K		SA520072C	
1 DF 25-1	C302	302.0.376				W01-M58-0776	1T 17 AR 4.5			836 M	1R 12-700	3836		SA520061A	
1 DF 25-11	C302	302.1.375				W01-M58-8722	1T 17 AR 4.5			836 MK1	1R 12-712	3836 K		SA520061C	
1 DF 25-13	C302	302.1.375/2				W01-M58-8721	1T 17 AR 4.5			836 M2 K1	1R 12-711	3836-02K		SA520069C	
1 DF 25-3	C302	302.0.376/2				W01-M58-0777	1T 17 AR 4.5			836 M2	1R 12-710	3836-02		SA520040	
1 DF 32	C292/S	292.1.533				W01-M58-8610	1T 66 D-10.8			725 NP03	1R 14-756	3725-01 K		SA520125C	
1 DF 32	C292/S	292.0.533	202964	1TCS 360-45		W01-M58-8610	1T 66 E10.8			725 NP01	1R 14-704	3725		SA520067	
1 DF 32	C292/S	292.1.534				W01-M58-8969	1T 66 E-10.8			725 NP02	1R 14-747	3725 K		SA520067C	
1 DK 19-1	C294/C	294.1.530								4915 NP06		34915-01 K			
1 DK 20 A1	C294	294.1.451				W01-M58-8186	1T 15 MPW-7			4157 NP06	1R 11-764	38186 KPP		SA520165C	
1 DK 20 A51	C294	294.1.450				W01-M58-6315	1T 15 MPW-7			4157 NP10	1R 11-772	39002-A3-01 KPP		SA520127C	
1 DK 20 B1	D278/HS	278.1.530/1				W01-M58-8185	1T 15 MPW-9			4158 NP03	1R 12-749	34158 KPP		SA520091C	
1 DK 20 B1	D278/HS	278.1.530				W01-M58-8185	1T 15 MPW-9			4158 NP03	1R 12-749	34158 KPP		SA520091C	
1 DK 20 C-2	C294	294.1.452				W01-M58-6317	1T 15 MPW-7			4157 NP08	1R 11-773	39002-A3-08 KPP		SA520181C	
1 DK 21	C293	293.0.511	204466	1TC 300-36		W01-M58-8620	1T 17 D-8.3			941 MB	1R 11-700	3941		SA520028	

I nominativi dei costruttori e i relativi riferimenti originali citati nel presente catalogo sono riportati a puro titolo indicativo. I nostri prodotti non sono originali ma con essi intercambiabili.
The name of manufacturers and the o.e. references mentioned in this catalogue are given for cross-reference purposes only. Our products are not original but interchangeable with.



**TABELLA COMPARATIVA MOLLE AD ARIA da codici PHOENIX
AIR SPRINGS CROSS-REFERENCE LIST from PHOENIX codes**

Phoenix		GART		CF Gomma		Firestone		Contitech		Goodyear		Airtech		Sabo	
Codice - Code	Tipo - Type	Codice - Code	Tipo - Type	Codice - Code	Tipo - Type	Codice - Code	Tipo - Type	Codice - Code	Code - Code	Codice - Code	Code - Code	Codice - Code	Code - Code	Codice - Code	Code - Code
1 DK 21 K	C293/A	293.0.411	1TC 300-30	W01-M58-8613	1T 17 D-4.3	940 MB	1R 11-703	940 MB	3940	1R 11-703	3940	SA520034			
1 DK 21 K	C293/A	293.2.414				4960		4960	34960 KPP		34960 KPP	SA520047C			
1 DK 21 K-1	C293/A	293.2.410		W01-M58-8609	1T 17 D-4.3	940 MB	1R 11-763	940 MB	3940 K	1R 11-763	3940 K	SA520034C			
1 DK 21 K-2	C293/A	293.2.412	1TC 300-30K	W01-M58-8595	1T 17 D-4.3	940 MB	1R 11-752	940 MB	3940 KPP	1R 11-752	3940 KPP	SA520129C			
1 DK 21 A2	D278/G	278.4.421	1T 323-32	W01-358-9361	1T 15 M-6	4156 NP06	1R 12-707	4156 NP06	34156 KPP	1R 12-707	34156 KPP	SA520089C			
1 DK 21 A3	C294	294.0.451	1TC 300-38	W01-M58-7074	1T 15 MPW-7	4157 NP05		4157 NP05	39002-A3		39002-A3	/			
1 DK 21 A3	C294	294.2.450/1		W01-M58-8840	1T 15 MPW-7										
1 DK 21 A31	C294	294.2.450	1TC 300-38	W01-M58-7074	1T 15 MPW-7	4157 NP09	1R 11-106	4157 NP09	39002-A3 KPP	1R 11-106	39002-A3 KPP	SA520036C			
1 DK 21 A4	C294	294.2.451	1T 300-40	W01-M58-6297	1T 15 MPW-7	4157 NP04	1R 11-111	4157 NP04	39002-A8 KPP	1R 11-111	39002-A8 KPP	SA520037C			
1 DK 21-1	C293	293.2.510	1TC 300-36	W01-M58-8619	1T 17 D-8.3	941 MB	1R 11-702 / 762	941 MB	3941 K	1R 11-702 / 762	3941 K	SA520028C			
1 DK 21-2	C293	293.2.512	1TC 300-36	W01-M58-8619	1T 17 D-8.3	941 MB	1R 11-743	941 MB	3941-01 KPP	1R 11-743	3941-01 KPP	SA520088C			
1 DK 22 E8	D278/S	278.4.452	1T 300-37	W01-M58-6366	1T 17 BS-6	4004 NP03	1R 11-713	4004 NP03	34004 KPP	1R 11-713	34004 KPP	SA520090C			
1 DK 22 E9	D278/S	278.4.454	1T 300-37	W01-M58-6367	1T 17 BS-6	4022 NP03	1R 11-714	4022 NP03	34022 KPP	1R 11-714	34022 KPP	SA520095C			
1 DK 23 K-9780	D278/R	278.1.430		W01-358-9780	1T 15 ZR-6		1R 12-603			1R 12-603					
1 DK 23 L-9131	D278/H	278.1.510	1T 323-40	W01-M58-9131	1T 15 M-9	4159 NP09	1R 12-721	4159 NP09	34159-02 KPP	1R 12-721	34159-02 KPP	SA520094C			
1 DK 23L-25	D278/H	278.2.511	1T 323-40	W01-379-9091 / 8859	1T 15 M-9	4159 NP07	1R 12-702	4159 NP07	34159-05 K	1R 12-702	34159-05 K	SA520128C			
1 DK 23L-27	D278/H	278.4.511	1T 323-40	W01-M58-7548	1T 15 M-9	4159 NP03	1R 12-701	4159 NP03	34159-10 KPP	1R 12-701	34159-10 KPP				
1 DK 25-1	D278/D	278.4.535		W01-M58-8747	1T 17 B-11		1R 13-150		30081 K	1R 13-150	30081 K				
1 DK 28 B7	D277/2F	277.2.500	1T 19 E-2	W01-M58-6361	1T 19 L-11		1R 14-706		391318 K	1R 14-706	391318 K	SA520021C			
1 DK 28 F4	D287/C	287.1.600	1T 19 E4	W01-M58-8786	1T 19 L-14	4912 NP07	1R 13-711	4912 NP07	34912 K	1R 13-711	34912 K	SA520060C			
1 DK 28 A7	D277/B	277.2.421	1T 19 E-1	W01-M58-8772	1T 19 L-7				36884 K		36884 K	SA520162C			
1 DK 28 D3	D287/B	287.4.581	1T 19 E-3	W01-M58-8762	1T 19 L-14				391304 K		391304 K	SA520019C			
1 DK 32	C292	292.0.531	1TC 360-45	W01-M58-8978	1T 66 D-10.8	881 MB	1R 14-708	881 MB	3881	1R 14-708	3881	SA520029			
1 DK 32 K-1	C292/A	292.2.460		W01-M58-8602	1T 66 D-7.0	4881 MB	1R 14-724	4881 MB	34881-01 K	1R 14-724	34881-01 K	SA520030C			
1 DK 32 K-2	C292/A	292.2.462	1TC 360-40K	W01-M58-8666	1T 66 D-7.0	4881 MB	1R 14-757	4881 MB	34881-01 KPP	1R 14-757	34881-01 KPP	SA520130C			
1 DK 32 K	C292/A	292.0.461	1TC 360-40	W01-M58-8601	1T 66 D-7.0	4881 NP02	1R 14-701	4881 NP02	34881	1R 14-701	34881	SA520030			
1 DK 32 L	C292/B	292.0.601		W01-M58-8611	1T 66 F-13.5	942 MB	1R 14-700	942 MB	3942	1R 14-700	3942	SA520068			
1 DK 32-1	C292	292.2.530	1TC 360-45	W01-M58-8966	1T 66 D-10.8	881 MB	1R 14-712	881 MB	3881-01 K	1R 14-712	3881-01 K	SA520029C			
1 DK 32-2	C292	292.2.532	1TC 360-45	W01-M58-8967	1T 66 D-10.8	881 MB	1R 14-748	881 MB	3881-01 KPP	1R 14-748	3881-01 KPP	SA520087C			
1 E 21	D276/B	276.0.390	1S 285-24	W01-095-0118	1R 1A 390 295	644 N	8017	644 N	3644	8017	3644	SA520002			
1 E 21 C	D276	276.0.420	1S 285-25	W01-095-0197	1R 1A 415 285	945 N	9013	945 N	3945	9013	3945	SA520003			
1 E 21 E	D290	290.0.420	1S 270-25	W01-095-0295	1R 1B 415-270	782 N		782 N	3782		3782	SA520065			

I nominativi dei costruttori e i relativi riferimenti originali citati nel presente catalogo sono riportati a puro titolo indicativo. I nostri prodotti non sono originali ma con essi intercambiabili.
The name of manufacturers and the o.e. references mentioned in this catalogue are given for cross-reference purposes only. Our products are not original but interchangeable with.



**TABELLA COMPARATIVA MOLLE AD ARIA da codici PHOENIX
AIR SPRINGS CROSS-REFERENCE LIST from PHOENIX codes**

Phoenix		GART		CF Gomma		Firestone		Contitech		Goodyear		Airtech		Sabo	
Codice - Code	Tipo - Type	Codice - Code	Tipo - Type	Codice - Code	Tipo - Type	Codice - Code	Tipo - Type	Codice - Code	Tipo - Type	Codice - Code	Tipo - Type	Codice - Code	Tipo - Type	Codice - Code	Tipo - Type
1 E 21-6	D290/B	97619	1S 270-23	W01-095-0121	1R 1B 390-270					9009		3944		SA520035	
1 E 25	D297	91016	1S 310-28-RF	W01-095-0021	1R 1C390-310			661 N		8018		3661		SA520009	
1 E 27	C302/A			W01-095-0213	1R2A 380 330			768 N				3768		SA520043	
1 E 32	C292/C	92594	1SC 360-30	W01-095-0207 / 0190	1R1D355-355 / 1R2D390-360			662 N / 762 N		9007 / 9010		3662 / 3762		SA520046 / A520048	
1 F 20 B1	C289/C	202265	1SC 270-30	W01-095-0429	1R 2A 445 280			1884 N1 / 1885 N1		9003		31885		SA520031	
1 F 21	C299	88802	1SC 290-30	W01-095-0195	1R 2A 460-295			720 N		9008		3720		SA520044	
1 F 21 C-5	C289/C1							916 N1		9015		3916		SA520097	
1 F 21 D	C304/B							713 N		9066		3713		SA520064	
1 F 32 B	C292/E	92593	1SC 360-43	W01-095-0192	1R2D 530 360			719 N		8118		3719		SA520083	
1 F 32A / 32A-2	C292/D	92575	1SC 360-34	W01-095-0191/ 0419	1R2D460 360 / 1R2D470 360			727 N / 728 N		8117		3727 / 3728		SA520084 / A520085	
1 F16	C289/D	97042	1SC 250-28	W01-095-0435	1R4R 465 260			882 N1							
1 KF 21-1	C304	207765	1VSC 285-30	W01-M58-8514	1R 7Z 440-290-B			4390 NP01 / NP21		9505		34390-01 K		SA520093C	
1 KF 21-1 NP	C304	206782	1VSC 285-30	W01-M58-0904	1R 7Z 440-290-B			4390 N1		9507		34390-01		SA520093	
1 KF 21-2	C304	207766	1VSC 285-30	W01-M58-8513	1R 7Z 440-290-C			4390 NP02 / NP22		9506		34390-02 K		SA520098C	
1 KF 21-2 NP	C304	206784	1VSC 285-30	W01-M58-0905	1R 7Z 440-290-C			4390 N2		9508		34390-02			
2 B 07 N	T281	84181	26	W01-M58-6988	26			603 N							
2 B 12 R	T291/2	206797	20	W01-M58-6910 / 6887	20			FD 200-19 1/4 M10		2B 9-223		2B-220 / 113001		SA520079	
2 B 12 R3	T291/2	207773	20	W01-M58-7894	20F			FD 200-19 P04		2B 9-700		2B-220-3 / 113002		SA520106	
2 B 12 RA-10	T291/2B	207776	20L	W01-M58-7394 / 7679	20-2			FD 200-25 1/4 M10		2B 9-269					
2 B 12 RA-3	T291/2B	207065	20L	W01-M58-6891	20-2			FD 200-25 P02		2B 9-701					
2 B 15 R	T272/N			W01-095-0219	260			620 N							
2 B 22 R	T271/2	88544	22	W01-M58-7524	22 D										
2 B 34 RA	T274/C	97900	21A BR	W01-M58-6989	21- D2										

I nominativi dei costruttori e i relativi riferimenti originali citati nel presente catalogo sono riportati a puro titolo indicativo. I nostri prodotti non sono originali ma con essi intercambiabili.
The name of manufacturers and the o.e. references mentioned in this catalogue are given for cross-reference purposes only. Our products are not original but interchangeable with.



TABELLA COMPARATIVA MOLLE AD ARIA da codici CONTITECH
AIR SPRINGS CROSS-REFERENCE LIST from CONTITECH codes

Contitech Codice - Code	GART		CF Gomma		Firestone		Phoenix		Goodyear		Airtech		Sabo	
	Codice	Tipo - Type	Codice - Code	Tipo - Type	Codice - Code	Tipo - Type	Codice - Code	Tipo - Type	Codice - Code	Tipo - Type	Codice - Code	Tipo - Type	Codice - Code	Tipo - Type
603 N	281.2.190	T281	84181	26	W01-M58-6988	26	2 B 07 N							
620 N	272.0.199	T272/N			W01-095-0219	260	2 B 15 R							
644 N	276.0.390	D276/B	92574	1S 285-24	W01-095-0118	1R 1A 390 295	1 E 21	8017	3644					SA520002
661 N	297.0.390	D297	91016	1S 310-28-RF	W01-095-0021	1R 1C390-310	1 E 25	8018	3661					SA520009
662 N / 762 N	292.0.380	C292/C	92594	1SC 360-30	W01-095-0207 / 0190	1R1D355-355 / 1R2D390-360	1 E 32	9007 / 9010	3662 / 3762					SA520046 / A520048
713 N	304.0.490	C304/B					1 F 21 D	9066	3713					SA520064
719 N	292.0.520	C292/E	92593	1SC 360-43	W01-095-0192	1R2D 530 360	1 F 32 B	8118	3719					SA520083
720 N	299.0.450	C299	88802	1SC 290-30	W01-095-0195	1R 2A 460-295	1 F 21	9008	3720					SA520044
725 NP01	292.0.533	C292/S	202964	1TCS 360-45		1T 66 E10.8	1 DF 32	1R 14-704	3725					SA520067
725 NP02	292.1.534	C292/S			W01-M58-8969	1T 66 E-10.8	1 DF 32	1R 14-747	3725 K					SA520067C
725 NP03	292.1.533	C292/S			W01-M58-8610	1T 66 D-10.8	1 DF 32	1R 14-756	3725-01 K					SA520125C
727 N / 728 N	292.0.450	C292/D	92575	1SC 360-34	W01-095-0191 / 0419	1R2D460 360 / 1R2D470 360	1 F 32A / 32A-2	8117	3727 / 3728					SA520084 / A520085
768 N	302.0.385	C302/A			W01-095-0213	1R2A 380 330	1 E 27		3768					SA520043
782 N	290.0.420	D290	97608	1S 270-25	W01-095-0295	1R 1B 415-270	1 E 21 E		3782					SA520065
810 MB	277.4.420	D277/B	874131	1T 19 E-1	W01-M58-8345 / 8775	1T 19 L-7	1 D 28 A2	1R 14-716	3810 K					SA520010C
810 N	277.0.424	D277/B							3810					
811	277.0.504	D277							3811-02					
811 MB 3 st	277.4.506	D277	203878	1T 19 E-2	W01-M58-6334	1T 19 F-11	1 D 28 B7	1R 14-718	3811 K					SA520081C
813 MB	277.4.500	D277	87408	1T 19 E-2	W01-M58-6364 / 6339	1T 19 L-11	1 D 28 B2	1R 14-705 (061)	3813 K					SA520070C
813 MB	277.4.507	D277	87408	1T 19 E-2	W01-M58-6364 / 6339	1T 19 L-11	1 D 28 B2	1R 14-705 (061)	3813 K					SA520070C
817 N	289.0.301	C289/BS	97326	1SC 240-30BB										
819 N	296.0.340	D296/D	90609	1S 215-22										
836 M	302.0.376	C302			W01-M58-0776	1T 17 AR 4.5	1 DF 25-1	1R 12-700	3819					SA520154
836 M2	302.0.376/2	C302			W01-M58-0777	1T 17 AR 4.5	1 DF 25-3	1R 12-710	3836					SA520061A
836 M2 K1	302.1.375/2	C302			W01-M58-8721	1T 17 AR 4.5	1 DF 25-13	1R 12-711	3836-02					SA520040
836 MK1	302.1.375	C302			W01-M58-8722	1T 17 AR 4.5	1 DF 25-11	1R 12-712	3836-02K					SA520069C
876 N	298.0.460	D298/C	92477	1S 323-34					3836 K					SA520061C
881 MB	292.0.531	C292	204530	1TC 360-45	W01-M58-8978	1T 66 D-10.8	1 DK 32	1R 14-708	3876					SA520101
881 MB	292.2.530	C292	205800	1TC 360-45	W01-M58-8966	1T 66 D-10.8	1 DK 32-1	1R 14-712	3881					SA520029
881 MB	292.2.532	C292	206357	1TC 360-45	W01-M58-8967	1T 66 D-10.8	1 DK 32-2	1R 14-748	3881-01 K					SA520029C
882 N1	289.0.400	C289/D	97042	1SC 250-28	W01-095-0435	1R4R 465 260	1 F 16		3881-01 KPP					SA520087C
912 NP01	287.4.601	D287/C	206333 / 207713	1T 19 E-2L				1R 14-728	32926 K					SA520132C

I nominativi dei costruttori e i relativi riferimenti originali citati nel presente catalogo sono riportati a puro titolo indicativo. I nostri prodotti non sono originali ma con essi intercambiabili.
The name of manufacturers and the o.e. references mentioned in this catalogue are given for cross-reference purposes only. Our products are not original but interchangeable with.



**TABELLA COMPARATIVA MOLLE AD ARIA da codici CONTITECH
AIR SPRINGS CROSS-REFERENCE LIST from CONTITECH codes**

Contitech		GART		CF Gamma		Firestone		Phoenix		Goodyear		Airtech		Sabo	
Codice - Code	Codice Tipo - Type	Codice - Code	Codice - Code	Tipo - Type	Codice - Code	Tipo - Type	Codice - Code	Tipo - Type	Codice - Code	Codice - Code	Codice - Code	Codice - Code	Codice - Code	Codice - Code	Codice - Code
912 NP02	D287/C	287.4.600			W01-M58-7385 / 8502	1 T19 L14	1 D 28 D2	1 D 28 D2				391314 K	SA520020C		
916 N1	C289/C1	289.0.455					1 F 21 C-5	1 F 21 C-5		9015		3916	SA520097		
940 MB	C293/A	293.2.412	207308	1TC 300-30K	W01-M58-8595	1T 17 D-4.3	1 DK 21 K-2	1 DK 21 K-2		1R 11-752		3940 KPP	SA520129C		
940 MB	C293/A	293.2.410			W01-M58-8609	1T 17 D-4.3	1 DK 21 K-1	1 DK 21 K-1		1R 11-763		3940 K	SA520034C		
940 MB	C293/A	293.0.411	205536	1TC 300-30	W01-M58-8613	1T 17 D-4.3	1 DK 21 K	1 DK 21 K		1R 11-703		3940	SA520034		
941 MB	C293	293.2.510	205170	1TC 300-36	W01-M58-8619	1T 17 D-8.3	1 DK 21-1	1 DK 21-1		1R 11-702 / 762		3941 K	SA520028C		
941 MB	C293	293.2.512	206356	1TC 300-36	W01-M58-8619	1T 17 D-8.3	1 DK 21-2	1 DK 21-2		1R 11-743		3941-01 KPP	SA520088C		
941 MB	C293	293.0.511	204466	1TC 300-36	W01-M58-8620	1T 17 D-8.3	1 DK 21	1 DK 21		1R 11-700		3941	SA520028		
942 MB	C292/B	292.0.601			W01-M58-8611	1T 66 F-13.5	1 DK 32 L	1 DK 32 L		1R 14-700		3942	SA520068		
943 N	D276/D	276.0.260	88809	1S 285-18	W01-095-0189	1R 1A 260 285				9001		3943	SA520026		
944 N	D276/C	276.0.370	88786	1S 285-22	W01-095-0198	1R 1A 370 285				8012		3944	SA520035		
945 N	D276	276.0.420	97555	1S 285-25	W01-095-0197	1R 1A 415 285	1 E 21 C	1 E 21 C		9013		3945	SA520003		
951 MB	C293/B	293.2.612													
951 MB	C293/B	293.0.611			W01-M58-8621	1T 17 D-11.8				1R 11-704		3951	SA520063		
975 N	D305	305.0.320													
1421 N	C299/E	299.0.490			W01-095-0472	1R 2A 490-305				9072		31421	SA520092		
1819 N	D296/C	296.0.360	202189	1S 215-23								3819	SA520154		
1884 N1 / 1885 N1	C289/C	289.0.450	202265	1SC 270-30	W01-095-0429	1R 2A 445 280	1 F 20 B1	1 F 20 B1		9003		31885	SA520031		
1924 N1	C289/E	289.0.360										31924	SA520155		
4004 NP02	D278/S	278.0.451								1R 11-705		34004	SA520062		
4004 NP03	D278/S	278.4.452								1R 11-713		34004 KPP	SA520090C		
4022 NP02	D278/S	278.0.452	203715	1T 300-37	W01-M58-6366	1T 17 BS-6	1 DK 22 E8	1 DK 22 E8		1R 11-709		34022	SA520055		
4022 NP03	D278/S	278.4.454	206340 (ex 204677)	1T 300-37	W01-M58-6367	1T 17 BS-6	1 DK 22 E9	1 DK 22 E9		1R 11-714		34022 KPP	SA520095C		
4022 NP05	D278/S	278.1.455	206358	1T 300-37	W01-M58-8612	1T 17 BS-6	1 DK 22 E9	1 DK 22 E9		1R 11-714		32619 KPP	SA520131C		
4023 NP05	D277	277.4.505	204676	1T 19 E-2	W01-M58-6348	1T 19 L-11	1 D 28 B10	1 D 28 B10		1R 14-729		34023 K	SA520059C		
4028 NP02	D287/E	287.4.540			W01-M58-8106	1T 19 L-12	1 D 28 F-1	1 D 28 F-1		1R 14-783		34028 K			
4156 NP05	D278/G	278.0.421										34156	SA520080		
4156 NP06	D278/G	278.4.421	97306 / 207777	1T 323-32	W01-358-9361	1T 15 M-6	1 DK 21 A2	1 DK 21 A2		1R 12-707		34156 KPP	SA520089C		
4157 NP04	C294	294.2.451	207463	1T 300-40	W01-M58-6297	1T 15 MPW-7	1 DK 21 A4	1 DK 21 A4		1R 11-111		39002-A8 KPP	SA520037C		
4157 NP05	C294	294.0.451	205598	1TC 300-38	W01-M58-7074	1T 15 MPW-7	1 DK 21 A3	1 DK 21 A3				39002-A3	/		
4157 NP06	C294	294.1.451			W01-M58-8186	1T 15 MPW-7	1 DK 20 A1	1 DK 20 A1		1R 11-764		38186 KPP	SA520165C		
4157 NP08	C294	294.1.452			W01-M58-6317	1T 15 MPW-7	1 DK 20 C-2	1 DK 20 C-2		1R 11-773		39002-A3-08 KPP	SA520181C		

I nominativi dei costruttori e i relativi riferimenti originali citati nel presente catalogo sono riportati a puro titolo indicativo. I nostri prodotti non sono originali ma con essi intercambiabili.
The name of manufacturers and the o.e. references mentioned in this catalogue are given for cross-reference purposes only. Our products are not original but interchangeable with.



**TABELLA COMPARATIVA MOLLE AD ARIA da codici CONTITECH
AIR SPRINGS CROSS-REFERENCE LIST from CONTITECH codes**

Contitech		GART		CF Gamma		Firestone		Phoenix		Goodyear		Airtech		Sabo	
Codice - Code	Codice	Code	Tipo - Type	Codice - Code	Tipo - Type	Codice - Code	Tipo - Type	Codice - Code	Tipo - Type	Codice - Code	Tipo - Type	Codice - Code	Tipo - Type	Codice - Code	Tipo - Type
4157 NP09	294.2.450	C294	205598	1TC 300-38	W01-M58-7074	1T 15 MPW-7	1 DK 21 A31	1R 11-106	39002-A3 KPP	SA520036C					
4157 NP10	294.1.450	C294			W01-M58-6315	1T 15 MPW-7	1 DK 20 A51	1R 11-772	39002-A3-01 KPP	SA520127C					
4158 NP02	278.0.531	D278/HS			W01-M58-6257	1T 15 MP-9			34158	SA520091					
4158 NP03	278.1.530	D278/HS			W01-M58-8185	1T 15 MPW-9	1 DK 20 B1	1R 12-749	34158 KPP	SA520091C					
4158 NP03	278.1.530/1	D278/HS			W01-M58-8185	1T 15 MPW-9	1 DK 20 B1	1R 12-749	34158 KPP	SA520091C					
4159 NP03	278.4.511	D278/H	204124/93800	1T 323-40	W01-M58-7548	1T 15 M-9	1 DK 23L-27	1R 12-701	34159-10 KPP						
4159 NP05	278.0.511	D278/H	206506	1T 323-40				1R 12-761	34159	SA520117					
4159 NP07	278.2.511	D278/H	202302 / 96978	1T 323-40	W01-379-9091 / 8859	1T 15 M-9	1 DK 23L-25	1R 12-702	34159-05 K	SA520128C					
4159 NP09	278.1.510	D278/H	200751	1T 323-40	W01-M58-9131	1T 15 M-9	1 DK 23 L-9131	1R 12-721	34159-02 KPP	SA520094C					
4183 N1	282.0.460	C282/C													
4183 N2	282.0.461	C282/C													
4183 NP23	282.1.461	C282/C													
4183 NP24	282.1.460	C282/C													
4390 N1	304.0.440	C304	206782	1VSC 285-30	W01-M58-0904	1R 7Z 440-290-B	1 KF 21-1 NP	9507	34390-01	SA520093					
4390 N2	304.0.441	C304	206784	1VSC 285-30	W01-M58-0905	1R 7Z 440-290-C	1 KF 21-2 NP	9508	34390-02						
4390 NP01 / NP21	304.1.440	C304	207765	1VSC 285-30	W01-M58-8514	1R 7Z 440-290-B	1 KF 21-1	9505	34390-01 K	SA520093C					
4390 NP02 / NP22	304.1.441	C304	207766	1VSC 285-30	W01-M58-8513	1R 7Z 440-290-C	1 KF 21-2	9506	34390-02 K	SA520098C					
4390 NP03	304.1.443	C304	206783	1VSC 285-30					34390-03 K						
4390 NP04	304.1.444	C304	206781	1VSC 285-30					34390-04 K						
4420 NP01	278.1.355	D278/V1	207774	1TS 300-28					34705 P						
4705 N1 P01	302.0.521	C302/B													
4705 N1 P03	302.1.520	C302/B													
4705 N1 P04	302.1.521	C302/B													
4713 N	293.0.461	C293/V	206778	1TS 300-28				1R 12-763	34713	SA520072					
4713 NP 02	293.1.460	C293/V	207775	1TS 300-28	W01-M58-9706		1 DF 22 C1	1R 12-762	34713 K	SA520072C					
4718 NP01	278.1.470	D278/V							34718 K	SA520121C					
4757 N1	299.0.461	C299/A			W01-M58-0909	1R 7Z 460-305-A		9517							
4757 N2	299.0.460	C299/A			W01-M58-0910	1R 7Z 460-305-B		9518							
4757 NP01 / NP21	299.1.461	C299/A	206785	1VSC 300-26	W01-M58-8521	1R 7Z 460-305-A		9519	34757-01 K	SA520177C					
4757 NP02/NP09/NP29	299.1.460	C299/A	206786	1VSC 300-26	W01-M58-8522	1R 7Z 460-305-B		9520	34757-02 K	SA520178C					
4810 NP05	277.4.423	D277/B	205456	1T 19 E-1	W01-M58-6338	1T 19 L-7	1 D 28 A10	1R 14-730	32918 K	SA520146C					
4813 NP07	287.4.520	D287	97764	Airspring E2	W01-M58-7358	1T 19 L-11	1 D 28 B9	1R 14-727	34813 K	SA520056C					

I nominativi dei costruttori e i relativi riferimenti originali citati nel presente catalogo sono riportati a puro titolo indicativo. I nostri prodotti non sono originali ma con essi intercambiabili.
The name of manufacturers and the o.e. references mentioned in this catalogue are given for cross-reference purposes only. Our products are not original but interchangeable with.



**TABELLA COMPARATIVA MOLLE AD ARIA da codici CONTITECH
AIR SPRINGS CROSS-REFERENCE LIST from CONTITECH codes**

Contitech		GART		CF Gamma		Firestone		Phoenix		Goodyear		Airtech		Sabo	
Codice - Code	Codice Tipo - Type	Codice - Code	Codice Tipo - Type	Codice - Code	Codice Tipo - Type	Codice - Code	Codice Tipo - Type	Codice - Code	Codice - Code	Codice - Code	Codice - Code	Codice - Code	Codice - Code	Codice - Code	Codice - Code
4881 MB	C292/A	292.2.462	207309	1TC 360-40K	W01-M58-8666	1T 66 D-7.0	1 DK 32 K-2	1R 14-757	34881-01 KPP	SA520130C					
4881 MB	C292/A	292.2.460	207309	1TC 360-40K	W01-M58-8602	1T 66 D-7.0	1 DK 32 K-1	1R 14-724	34881-01 K	SA520030C					
4881 NP02	C292/A	292.0.461	205537	1TC 360-40	W01-M58-8601	1T 66 D-7.0	1 DK 32 K	1R 14-701	34881	SA520030					
4882 N1 P01	C289/M	289.0.512	207760	1TS 260-32					34882	SA520187					
4882 N1 P05	C289/M	289.1.510	207701	1TS 260-32	W01-M58-9880	1T 17 TWR-8		1R 11-804	34882 K	SA520187C					
4883 N1 P01	C304/M3	304.0.513	207761	1TS 290-28					34883	SA520188					
4883 N1 P06	C304/M3	304.1.513							34883 K	SA520188C					
4884 N1 P01	C304/M4	304.0.511	207759	1TS 290-28				1R 11-820	34884	SA520189					
4884 N1 P06	C304/M4	304.1.510	207702	1TS 290-28	W01-M58-9879	1T 17 JR-7,2			34884 K	SA520189C					
4884 N1 P07	C289/M	289.1.513													
4885 N1 P01	C289/M1	289.0.411	207762	1TS 260-20											
4885 N1 P02	C289/M1	289.1.410	207764	1TS 260-20											
4911 N	D287/E	287.0.541							34911 N	SA520075					
4911 NP03	D287/E	287.1.540	207770	1T 19 E3				1R 13-714	34911 K	SA520075C					
4911 NP04	D287/E	287.1.541	207771	1T 19 E3					34911-04 K						
4911 NP06	D287/E	287.1.542													
4912 NP07	D287/C	287.1.600	206779	1T 19 E4	W01-M58-8786	1T 19 L-14	1 DK 28 F4	1R 13-711	34912 K	SA520060C					
4912 NP08	D287/C	287.0.601	206780	1T 19 E4					34912	SA520060					
4912 NP10	D287/C	287.1.603	207769	1T 19 E4					34912-10 K	SA520241C					
4912 NP13	D287/C	287.1.602													
4913 NP02	D287/H	287.1.606	206201	1T 19 E-93	W01-M58-9881	1T 19 L-14	1 D 28 H16	1R 14-753	34913 K	SA520045C					
4913 NP04	D287/H	287.0.603	207772	1T 19 E-93	W01-095-0365	1T 19 F-14		1R 14-755	34913	SA520045					
4915 NP03	C294/C	294.0.531							34915 P						
4915 NP06	C294/C	294.1.530					1 DK 19-1		34915-01 K						
4940 NP02	C293/A	293.0.413							34940	SA520053					
4941 NP02	C293	293.0.513							34941	SA520054					
4960	C293/A	293.2.414					1 DK 21 K		34960 KPP	SA520047C					
4960	C293/A	293.2.415	207710	1TC 300-30											
4960 NP02	C293/A	293.0.412	207711	1TC 300-30			1 D 21 K-3	1R 11-801	34960	SA520047					
4961 NP02	C293/A	293.0.414							34961	SA520071					
4962 NP02	C293	293.0.514													
4963 NP01	C293	293.2.514													

I nominativi dei costruttori e i relativi riferimenti originali citati nel presente catalogo sono riportati a puro titolo indicativo. I nostri prodotti non sono originali ma con essi intercambiabili.
The name of manufacturers and the o.e. references mentioned in this catalogue are given for cross-reference purposes only. Our products are not original but interchangeable with.



**TABELLA COMPARATIVA MOLLE AD ARIA da codici CONTITECH
AIR SPRINGS CROSS-REFERENCE LIST from CONTITECH codes**

Contitech Codice - Code	GART		CF Gamma		Firestone		Phoenix		Goodyear		Airtech		Sabo	
	Codice	Tipo - Type	Codice - Code	Tipo - Type	Codice - Code	Tipo - Type	Codice - Code	Tipo - Type	Codice - Code	Tipo - Type	Codice - Code	Tipo - Type	Codice - Code	Tipo - Type
6605 NP01	294.1.430	C294/V			W01-M58-8472	1T 15 LRN-6	1 DF 20 D-1	1R 11-805	37803 K			SA520182C		
6605 NP01	294.0.431	C294/V							37803			SA520182		
6606 NP01	294.1.370	C294/VA			W01-M58-8477	1T 15 LRN-3	1 DF 20 E-1	1R 11-848	37804 K			SA520215C		
6607 NP01	295.1.400	C295/VA			W01-M58-8473	1T 15 UR-6			36418 K			SA520208C		
6608 NP01	295.1.465	C295/V			W01-M58-8474	1T 15 UR-9		1R 10-704	36416 K			SA520175C		
9718 N	278.0.471	D278/V												
FD 200-19 1/4 M10	291.2.200	T291/2	20	20	W01-M58-6910 / 6887	20	2 B 12 R	2B 9-223	2B-220 / 113001			SA520079		
FD 200-19 P04	291.2.203	T291/2	20	20	W01-M58-7894	20F	2 B 12 R3	2B 9-700	2B-220-3 / 113002			SA520106		
FD 200-25 1/4 M10	291.2.260	T291/2B	20L	20L	W01-M58-7394 / 7679	20-2	2 B 12 RA-10	2B 9-269						
FD 200-25 P02	291.2.263	T291/2B	20L	20L	W01-M58-6891	20-2	2 B 12 RA-3	2B 9-701						

I nominativi dei costruttori e i relativi riferimenti originali citati nel presente catalogo sono riportati a puro titolo indicativo. I nostri prodotti non sono originali ma con essi intercambiabili.
The name of manufacturers and the o.e. references mentioned in this catalogue are given for cross-reference purposes only. Our products are not original but interchangeable with.



**TABELLA COMPARATIVA MOLLE AD ARIA da codici GOODYEAR
AIR SPRINGS CROSS-REFERENCE LIST from GOODYEAR codes**

Goodyear		GART		CF Gamma		Firestone		Phoenix		Contitech		Airttech		Sabo	
Codice - Code	Tipo - Type	Codice - Code	Tipo - Type	Codice - Code	Tipo - Type	Codice - Code	Tipo - Type	Codice - Code	Tipo - Type	Codice - Code	Tipo - Type	Codice - Code	Tipo - Type	Codice - Code	Tipo - Type
8012	D276/C	88786	1S 285-22	W01-095-0198	1R 1A 370 285		944 N		944 N		3944		SA520035		
8017	D276/B	92574	1S 285-24	W01-095-0118	1R 1A 390 295		644 N	1 E 21	644 N		3644		SA520002		
8018	D297	91016	1S 310-28-RF	W01-095-0021	1R 1C390-310		661 N	1 E 25	661 N		3661		SA520009		
8117	C292/D	92575	1SC 360-34	W01-095-0191/0419	1R2D460 360 / 1R2D470 360		727 N / 728 N	1 F 32A / 32A-2	727 N / 728 N		3727 / 3728		SA520084 / A520085		
8118	C292/E	92593	1SC 360-43	W01-095-0192	1R2D 530 360		719 N	1 F 32 B	719 N		3719		SA520083		
8314	D298/B	203833	1S 323-36												
8325	T291/2	86600	20	W01-M68-6990	20										
9001	D276/D	88809	1S 285-18	W01-095-0189	1R 1A 260 285		943 N	1 F 20 B1	943 N		3943		SA520026		
9003	C289/C	202265	1SC 270-30	W01-095-0429	1R 2A 445 280		1884 N1 / 1885 N1	1 F 20 B1	1884 N1 / 1885 N1		31885		SA520031		
9007 / 9010	C292/C	92594	1SC 360-30	W01-095-0207 / 0190	1R1D355-355 / 1R2D390-360		662 N / 762 N	1 E 32	662 N / 762 N		3662 / 3762		SA520046 / A520048		
9008	C299	88802	1SC 290-30	W01-095-0195	1R 2A 460-295		720 N	1 F 21	720 N		3720		SA520044		
9009	D290/B	97619	1S 270-23	W01-095-0121	1R 1B 390-270		1 E 21-6	1 E 21-6	1 E 21-6		3944		SA520035		
9012	C301	204250	1SC 250-29BB												
9013	D276	97555	1S 285-25	W01-095-0197	1R 1A 415 285		945 N	1 E 21 C	945 N		3945		SA520003		
9015	C289/C1						916 N1	1 F 21 C-5	916 N1		3916		SA520097		
9066	C304/B						713 N	1 F 21 D	713 N		3713		SA520064		
9072	C299/E			W01-095-0472	1R 2A 490-305		1421 N		1421 N		31421		SA520092		
9505	C304	207765	1VSC 285-30	W01-M68-8514	1R 7Z 440-290-B		1 KF 21-1	1 KF 21-1	4390 NP01 / NP21		34390-01 K		SA520098C		
9506	C304	207766	1VSC 285-30	W01-M68-8513	1R 7Z 440-290-C		1 KF 21-2	1 KF 21-2	4390 NP02 / NP22		34390-02 K		SA520098C		
9507	C304	206782	1VSC 285-30	W01-M68-0904	1R 7Z 440-290-B		1 KF 21-1 NP	1 KF 21-1 NP	4390 N1		34390-01		SA520093		
9508	C304	206784	1VSC 285-30	W01-M68-0905	1R 7Z 440-290-C		1 KF 21-2 NP	1 KF 21-2 NP	4390 N2		34390-02				
9517	C299/A			W01-M68-0909	1R 7Z 460-305-A		4757 N1		4757 N1						
9518	C299/A			W01-M68-0910	1R 7Z 460-305-B		4757 N2		4757 N2						
9519	C299/A	206785	1VSC 300-26	W01-M68-8521	1R 7Z 460-305-A		4757 NP01 / NP21	1 F 21 C	4757 NP01 / NP21		34757-01 K		SA520177C		
9520	C299/A	206786	1VSC 300-26	W01-M68-8522	1R 7Z 460-305-B		4757 NP02/NP09/NP29	1 F 21 C-5	4757 NP02/NP09/NP29		34757-02 K		SA520178C		
1R 10-704	C295/V			W01-M68-8474	1T 15 UR-9		6608 NP01		6608 NP01		36416 K		SA520175C		
1R 11-106	C294	205598	1TC 300-38	W01-M68-7074	1T 15 MPW-7		1 DK 21 A31	1 DK 21 A31	4157 NP09		39002-A3 KPP		SA520036C		
1R 11-111	C294	207463	1T 300-40	W01-M68-6297	1T 15 MPW-7		1 DK 21 A4	1 DK 21 A4	4157 NP04		39002-A8 KPP		SA520037C		
1R 11-700	C293	204466	1TC 300-36	W01-M68-8620	1T 17 D-8.3		1 DK 21	1 DK 21	941 MB		3941		SA520028		
1R 11-702 / 762	C293	205170	1TC 300-36	W01-M68-8619	1T 17 D-8.3		1 DK 21-1	1 DK 21-1	941 MB		3941 K		SA520028C		
1R 11-703	C293/A	205536	1TC 300-30	W01-M68-8613	1T 17 D-4.3		1 DK 21 K	1 DK 21 K	940 MB		3940		SA520034		
1R 11-704	C293/B			W01-M68-8621	1T 17 D-11.8		1 DK 21 K	1 DK 21 K	951 MB		3951		SA520063		

I nominativi dei costruttori e i relativi riferimenti originali citati nel presente catalogo sono riportati a puro titolo indicativo. I nostri prodotti non sono originali ma con essi intercambiabili. The name of manufacturers and the o.e. references mentioned in this catalogue are given for cross-reference purposes only. Our products are not original but interchangeable with.



**TABELLA COMPARATIVA MOLLE AD ARIA da codici GOODYEAR
AIR SPRINGS CROSS-REFERENCE LIST from GOODYEAR codes**

Goodyear		GART		CF Gomma		Firestone		Phoenix		Contitech		Airtech		Sabo	
Codice - Code	Typo - Type	Codice - Code	Typo - Type	Codice - Code	Typo - Type	Codice - Code	Typo - Type	Codice - Code	Typo - Type	Codice - Code	Typo - Type	Codice - Code	Typo - Type	Codice - Code	Typo - Type
1R 11-705	D278/S	278.0.451									4004 NP02	34004		SA520062	
1R 11-709	D278/S	278.0.452					1T 17 BS-6				4022 NP02	34022		SA520055	
1R 11-710	D278/S	278.4.453			1T 300-37							34022 K		SA520055C	
1R 11-713	D278/S	278.4.452	203715		1T 300-37			1 DK 22 E8			4004 NP03	34004 KPP		SA520090C	
1R 11-714	D278/S	278.4.454	206340 (ex.204677)		1T 300-37			1 DK 22 E9			4022 NP03	34022 KPP		SA520095C	
1R 11-743	C293	293.2.512	206956		1TC 300-36		1T 17 D-8.3	1 DK 21-2			941 MB	3941-01 KPP		SA520088C	
1R 11-752	C293/A	293.2.412	207508		1TC 300-30K		1T 17 D-4.3	1 DK 21 K-2			940 MB	3940 KPP		SA520129C	
1R 11-763	C293/A	293.2.410					1T 17 D-4.3	1 DK 21 K-1			940 MB	3940 K		SA520034C	
1R 11-764	C294	294.1.451					1T 15 MPW-7	1 DK 20 A1			4157 NP06	38186 KPP		SA520165C	
1R 11-772	C294	294.1.450					1T 15 MPW-7	1 DK 20 A51			4157 NP10	39002-A3-01 KPP		SA520127C	
1R 11-773	C294	294.1.452					1T 15 MPW-7	1 DK 20 C-2			4157 NP08	39002-A3-08 KPP		SA520181C	
1R 11-801	C293/A	293.0.412	207711		1TC 300-30			1 D 21 K-3			4960 NP02	34960		SA520047	
1R 11-804	C304/M3	304.0.513	207761		1TS 290-28						4883 N1 P01	34883		SA520188	
1R 11-805	C294/V	294.1.430					1T 15 LRN-6	1 DF 20 D-1			6605 NP01	37803 K		SA520182C	
1R 11-820	C304/M4	304.0.511	207759		1TS 290-28						4884 N1 P01	34884		SA520189	
1R 11-829	D297/B	297.1.430										330304 K		SA520196C	
1R 11-830	D297/B	297.1.431										330305 K		SA520202C	
1R 11-832	D297/B	297.1.432										334506 K		SA520201C	
1R 11-833	D297/A	297.2.315										331114 K		SA520199C	
1R 11-834	D297/B	297.1.430/1										331240 K			
1R 11-837	D297/A	297.2.315/1										331239 K			
1R 11-838	D297/B	297.1.432/1										331243 K			
1R 11-840	D297/B	297.1.431/1										331241 K			
1R 11-841	D297/C	297.1.300/1										331246 K			
1R 11-845	D297/C	297.1.300										330307 K		SA520197C	
1R 11-848	C294/VA	294.1.370					1T 15 LRN-3	1 DF 20 E-1			6606 NP01	37804 K		SA520215C	
1R 12-603	D278/R	278.1.430					1T 15 ZR-6	1 DK 23 K-9780							
1R 12-700	C302	302.0.376					1T 17 AR 4.5	1 DF 25-1			836 M	3836		SA520061A	
1R 12-701	D278/H	278.4.511	204124/93800		1T 323-40			1 DK 23L-27			4159 NP03	34159-10 KPP		SA520128C	
1R 12-702	D278/H	278.2.511	202302 /96978		1T 323-40			1 DK 23L-25			4159 NP07	34159-05 K		SA520128C	
1R 12-703	D278/H	278.4.516	97307		1T 323-40 BG							391210 K		SA520006C	
1R 12-703	D278/H	278.2.512	96871		1T 323-40							391209 K		SA520023C	

I nominativi dei costruttori e i relativi riferimenti originali citati nel presente catalogo sono riportati a puro titolo indicativo. I nostri prodotti non sono originali ma con essi intercambiabili.
The name of manufacturers and the o.e. references mentioned in this catalogue are given for cross-reference purposes only. Our products are not original but interchangeable with.



**TABELLA COMPARATIVA MOLLE AD ARIA da codici GOODYEAR
AIR SPRINGS CROSS-REFERENCE LIST from GOODYEAR codes**

Goodyear		GART		CF Gamma		Firestone		Phoenix		Contitech		Airtech		Sabo	
Code - Code	Code - Code	Code - Code	Code - Code	Code - Code	Code - Code	Code - Code	Code - Code	Code - Code	Code - Code	Code - Code	Code - Code	Code - Code	Code - Code	Code - Code	Code - Code
		Typo - Type	Typo - Type	Typo - Type	Typo - Type	Typo - Type	Typo - Type	Typo - Type	Typo - Type	Typo - Type	Typo - Type	Typo - Type	Typo - Type	Typo - Type	Typo - Type
1R 12-705	278.2.422	D278/G	98873	1T 323-33											
1R 12-707	278.4.421	D278/G	97306 / 207777	1T 323-32	W01-358-9361	1T 15 M-6	W01-358-9361	1 DK 21 A2	4156 NP06	34156 KPP	SA520089C				
1R 12-710	302.0.376/2	C302			W01-M58-0777	1T 17 AR 4.5	W01-M58-0777	1 DF 25-3	836 M2	3836-02	SA520040				
1R 12-711	302.1.375/2	C302			W01-M58-8721	1T 17 AR 4.5	W01-M58-8721	1 DF 25-13	836 M2 K1	3836-02K	SA520069C				
1R 12-712	302.1.375	C302			W01-M58-8722	1T 17 AR 4.5	W01-M58-8722	1 DF 25-11	836 MK1	3836 K	SA520061C				
1R 12-721	278.1.510	D278/H	200751	1T 323-40	W01-M58-9131	1T 15 M-9	W01-M58-9131	1 DK 28 L-9131	4159 NP09	34159-02 KPP	SA520094C				
1R 12-749	278.1.530	D278/HS			W01-M58-8185	1T 15 MPW-9	W01-M58-8185	1 DK 20 B1	4158 NP03	34158 KPP	SA520091C				
1R 12-749	278.1.530/1	D278/HS			W01-M58-8185	1T 15 MPW-9	W01-M58-8185	1 DK 20 B1	4158 NP03	34158 KPP	SA520091C				
1R 12-761	278.0.511	D278/H	206506	1T 323-40					4159 NP05	34159	SA520117				
1R 12-762	293.1.460	C293/V	207775	1TS 300-28	W01-M58-9706		W01-M58-9706	1 DF 22 C1	4713 NP 02	34713 K	SA520072C				
1R 12-763	293.0.461	C293/V	206778	1TS 300-28					4713 N	34713	SA520072				
1R 12-809	278.2.330	D278/N			W01-M58-8193	1T 15 VPR-3	W01-M58-8193			330302 K	SA520056C				
1R 12-813	278.2.330/1	D278/N								331238 K					
1R 13-150	278.4.535	D278/D			W01-M58-8747	1T 17 B-11	W01-M58-8747	1 DK 25-1		30081 K					
1R 13-711	287.1.600	D287/C	206779	1T 19 E4	W01-M58-8786	1T 19 L-14	W01-M58-8786	1 DK 28 F4	4912 NP07	34912 K	SA520060C				
1R 13-714	287.1.540	D287/E	207770	1T 19 E3					4911 NP03	34911 K	SA520075C				
1R 13-734	287.4.580	D287/B	97343	1T 19 E-3	W01-M58-7380 / 8765	1T 19 L-12	W01-M58-7380 / 8765	1 D 28 C12		391303 K	SA520012C				
1R 13-746	278.2.300	D278/NA			W01-M58-8192	1T 15 VR-3	W01-M58-8192			330301 K	SA520198C				
1R 13-750	278.2.300/1	D278/NA								331237 K					
1R 14-700	292.0.601	C292/B			W01-M58-8611	1T 66 F-13.5	W01-M58-8611	1 DK 32 L	942 MB	3942	SA520068				
1R 14-701	292.0.461	C292/A	205537	1TC 360-40	W01-M58-8601	1T 66 D-7.0	W01-M58-8601	1 DK 32 K	4881 NP02	34881	SA520030				
1R 14-704	292.0.533	C292/S	202964	1TCS 360-45					725 NP01	3725	SA520067				
1R 14-705 (061)	277.4.500	D277	87408	1T 19 E-2	W01-M58-6364 / 6339	1T 19 L-11	W01-M58-6364 / 6339	1 D 28 B2	813 MB	3813 K	SA520070C				
1R 14-705 (061)	277.4.507	D277	87408	1T 19 E-2	W01-M58-6364 / 6339	1T 19 L-11	W01-M58-6364 / 6339	1 D 28 B2	813 MB	3813 K	SA520070C				
1R 14-706	277.2.500	D277/2F	204371 (ex 93762)	1T 19 E-2	W01-M58-6361	1T 19 L-11	W01-M58-6361	1 DK 28 B7		391318 K	SA520021C				
1R 14-707	287.2.510	D287/A	97039	Airspring E2	W01-M58-8795	1T 19 L-11	W01-M58-8795								
1R 14-708	292.0.531	C292	204530	1TC 360-45	W01-M58-8978	1T 66 D-10.8	W01-M58-8978	1 DK 32	881 MB	3881	SA520029				
1R 14-709	287.4.512	D287/A			W01-M58-7502	1T 19 L 11	W01-M58-7502	1 D 28 B4							
1R 14-712	292.2.530	C292	205800	1TC 360-45	W01-M58-8966	1T 66 D-10.8	W01-M58-8966	1 DK 32-1	881 MB	3881-01 K	SA520029C				
1R 14-716	277.4.420	D277/B	87413/1	1T 19 E-1	W01-M58-6345 / 8775	1T 19 L-7	W01-M58-6345 / 8775	1 D 28 A2	810 MB	3810 K	SA520010C				
1R 14-718	277.4.506	D277	203878	1T 19E-2	W01-M58-6334	1T 19 F-11	W01-M58-6334	1 D 28 B7	811 MB 3 st	3811 K	SA520081C				
1R 14-721	287.4.521	D287			W01-M58-7370	1T 19 L-11	W01-M58-7370								

I nominativi dei costruttori e i relativi riferimenti originali citati nel presente catalogo sono riportati a puro titolo indicativo. I nostri prodotti non sono originali ma con essi intercambiabili.
The name of manufacturers and the o.e. references mentioned in this catalogue are given for cross-reference purposes only. Our products are not original but interchangeable with.



**TABELLA COMPARATIVA MOLLE AD ARIA da codici GOODYEAR
AIR SPRINGS CROSS-REFERENCE LIST from GOODYEAR codes**

Goodyear		GART		CF Gomma		Firestone		Phoenix		Contitech		Airtech		Sabro	
Codice - Code	Typo - Type	Codice - Code	Typo - Type	Codice - Code	Typo - Type	Codice - Code	Typo - Type	Codice - Code	Typo - Type	Codice - Code	Typo - Type	Codice - Code	Typo - Type	Codice - Code	Typo - Type
1R 14-724	C292/A	292.2.460				W01-M58-8602	1T 66 D-7.0	1 DK 32 K-1	4881 MB	34881-01 K	4881 MB	34881-01 K	SA520030C		
1R 14-727	D287	287.4.520	Airspring E2	97764		W01-M58-7358	1T 19 L-11	1 D 28 B9	4813 NP07	34813 K	4813 NP07	34813 K	SA520056C		
1R 14-728	D287/C	287.4.601	1T 19 E-2L	206333 / 207713					912 NP01	32926 K	912 NP01	32926 K	SA520132C		
1R 14-729	D277	277.4.505	1T 19 E-2	204676		W01-M58-6348	1T 19 L-11	1 D 28 B10	4023 NP03	34023 K	4023 NP03	34023 K	SA520059C		
1R 14-730	D277/B	277.4.423	1T 19 E-1	205456		W01-M58-6338	1T 19 L-7	1 D 28 A10	4810 NP05	32918 K	4810 NP05	32918 K	SA520146C		
1R 14-747	C292/S	292.1.534				W01-M58-8969	1T 66 E-10.8	1 DF 32	725 NP02	3725 K	725 NP02	3725 K	SA520067C		
1R 14-748	C292	292.2.532	1TC 360-45	206357		W01-M58-8967	1T 66 D-10.8	1 DK 32-2	881 MB	3881-01 KPP	881 MB	3881-01 KPP	SA520087C		
1R 14-753	D287/H	287.1.606	1T 19 E-93	206201		W01-M58-9881	1T 19 L-14	1 D 28 H16	4913 NP02	34913 K	4913 NP02	34913 K	SA520045C		
1R 14-755	D287/H	287.0.603	1T 19 E-93	207772		W01-095-0365	1T 19 F-14		4913 NP04	34913	4913 NP04	34913	SA520045		
1R 14-756	C292/S	292.1.533				W01-M58-8610	1T 66 D-10.8	1 DF 32	725 NP03	3725-01 K	725 NP03	3725-01 K	SA520125C		
1R 14-757	C292/A	292.2.462	1TC 360-40K	207309		W01-M58-8666	1T 66 D-7.0	1 DK 32 K-2	4881 MB	34881-01 KPP	4881 MB	34881-01 KPP	SA520130C		
1R 14-783	D287/E	287.4.540				W01-M58-8106	1T 19 L-12	1 D 28 F-1	4028 NP02	34028 K	4028 NP02	34028 K			
2B 9-223	T291/2	291.2.200	20	206797		W01-M58-6910 / 6887	20	2 B 12 R	FD 200-19-1/4 M10	2B-220 / 113001	FD 200-19-1/4 M10	2B-220 / 113001	SA520079		
2B 9-269	T291/2B	291.2.260	20L	207776		W01-M58-7394 / 7679	20-2	2 B 12 RA-10	FD 200-25 1/4 M10		FD 200-25 1/4 M10				
2B 9-287	T291/2B	291.2.262													
2B 9-700	T291/2	291.2.203	20	207773		W01-M58-7894	20F	2 B 12 R3	FD 200-19 P04	2B-220-3 / 113002	FD 200-19 P04	2B-220-3 / 113002	SA520106		
2B 9-701	T291/2B	291.2.263	20L	207065		W01-M58-6891	20-2	2 B 12 RA-3	FD 200-25 P02		FD 200-25 P02				
2B12-425	T271/2	271.2.204	22 B	86624											

I nominativi dei costruttori e i relativi riferimenti originali citati nel presente catalogo sono riportati a puro titolo indicativo. I nostri prodotti non sono originali ma con essi intercambiabili.
The name of manufacturers and the c.e. references mentioned in this catalogue are given for cross-reference purposes only. Our products are not original but interchangeable with.



**TABELLA COMPARATIVA MOLLE AD ARIA da codici AIRTECH
AIR SPRINGS CROSS-REFERENCE LIST from AIRTECH codes**

Airtech		GART		CF Gomma		Firestone		Phoenix		Contitech		Goodyear		Sabo	
Codice - Code	Tipo - Type	Codice - Code	Tipo - Type	Codice - Code	Tipo - Type	Codice Code	Tipo - Type	Codice - Code	Codice - Code	Codice - Code	Codice - Code	Codice - Code	Codice - Code	Codice - Code	Codice - Code
3644	D276/B	276.0.390	D276/B	92574	1S 285-24	W01-095-0118	1R 1A 390 295	1 E 21	644 N	8017	SA520002				
3661	D297	297.0.390	D297	91016	1S 310-28-RF	W01-095-0021	1R 1C390-310	1 E 25	661 N	8018	SA520009				
3662 / 3762	C292/C	292.0.380	C292/C	92594	1SC 360-30	W01-095-0207 / 0190	1R1D355-355 / 1R2D390-360	1 E 32	662 N / 762 N	9007 / 9010	SA520046 / A520048				
3713	C304/B	304.0.490	C304/B					1 F 21 D	713 N	9066	SA520064				
3719	C292/E	292.0.520	C292/E	92593	1SC 360-43	W01-095-0192	1R2D 530 360	1 F 32 B	719 N	8118	SA520083				
3720	C299	299.0.450	C299	88802	1SC 290-30	W01-095-0195	1R 2A 460-295	1 F 21	720 N	9008	SA520044				
3725	C292/S	292.0.533	C292/S	202964	1TCS 360-45		1T 66 E10.8	1 DF 32	725 NP01	1R 14-704	SA520067				
3725 K	C292/S	292.1.534	C292/S			W01-M58-8969	1T 66 E-10.8	1 DF 32	725 NP02	1R 14-747	SA520067C				
3725-01 K	C292/S	292.1.533	C292/S			W01-M58-8610	1T 66 D-10.8	1 DF 32	725 NP03	1R 14-756	SA520125C				
3727 / 3728	C292/D	292.0.450	C292/D	92575	1SC 360-34	W01-095-0191 / 0419	1R2D460 360 / 1R2D470 360	1 F 32A / 32A-2	727 N / 728 N	8117	SA520084 / A520085				
3768	C302/A	302.0.385	C302/A			W01-095-0213	1R2A 380 330	1 E 27	768 N		SA520043				
3782	D290	290.0.420	D290	97608	1S 270-25	W01-095-0295	1R 1B 415-270	1 E 21 E	782 N		SA520065				
3810	D277/B	277.0.424	D277/B						810 N						
3810 K	D277/B	277.4.420	D277/B	87413/1	1T 19 E-1	W01-M58-6345 / 8775	1T 19 L-7	1 D 28 A2	810 MB	1R 14-716	SA520010C				
3811 K	D277	277.4.506	D277	203878	1T 19E-2	W01-M58-6334	1T 19 F-11	1 D 28 B7	811 MB 3 st	1R 14-718	SA520081C				
3811-02	D277	277.0.504	D277						811						
3811-02 K	D287	287.4.522	D287								SA520174C				
3813 K	D277	277.4.507	D277	87408	1T 19 E-2	W01-M58-6364 / 6339	1T 19 L-11	1 D 28 B2	813 MB	1R 14-705 (061)	SA520070C				
3813 K	D277	277.4.500	D277	87408	1T 19 E-2	W01-M58-6364 / 6339	1T 19 L-11	1 D 28 B2	813 MB	1R 14-705 (061)	SA520070C				
3813-03 K	D277/D	277.4.520	D277/D								SA520169C				
3819	D296/D	296.0.340	D296/D	90609	1S 215-22				819 N		SA520154				
3819	D296/C	296.0.360	D296/C	202189	1S 215-23				1819 N		SA520154				
3836	C302	302.0.376	C302			W01-M58-0776	1T 17 AR 4.5	1 DF 25-1	836 M	1R 12-700	SA520061A				
3836 K	C302	302.1.375	C302			W01-M58-8722	1T 17 AR 4.5	1 DF 25-11	836 MK1	1R 12-712	SA520061C				
3836-02	C302	302.0.376/2	C302			W01-M58-0777	1T 17 AR 4.5	1 DF 25-3	836 M2	1R 12-710	SA520040				
3836-02K	C302	302.1.375/2	C302			W01-M58-8721	1T 17 AR 4.5	1 DF 25-13	836 M2 K1	1R 12-711	SA520069C				
3876	D298/C	298.0.460	D298/C	92477	1S 323-34				876 N		SA520101				
3881	C292	292.0.531	C292	204530	1TC 360-45	W01-M58-8978	1T 66 D-10.8	1 DK 32	881 MB	1R 14-708	SA520029				
3881-01 K	C292	292.2.530	C292	205800	1TC 360-45	W01-M58-8966	1T 66 D-10.8	1 DK 32-1	881 MB	1R 14-712	SA520029C				
3881-01 KPP	C292	292.2.532	C292	206357	1TC 360-45	W01-M58-8967	1T 66 D-10.8	1 DK 32-2	881 MB	1R 14-748	SA520087C				
3897	D278	278.0.430	D278	88788	1S 320-30						SA520032				

I nominativi dei costruttori e i relativi riferimenti originali citati nel presente catalogo sono riportati a puro titolo indicativo. I nostri prodotti non sono originali ma con essi intercambiabili.

The name of manufacturers and the o.e. references mentioned in this catalogue are given for cross-reference purposes only. Our products are not original but interchangeable with.

* Solo per il mercato italiano * Only for Italian market



**TABELLA COMPARATIVA MOLLE AD ARIA da codici AIRTECH
AIR SPRINGS CROSS-REFERENCE LIST from AIRTECH codes**

Airtech		GART		CF Gomma		Firestone		Phoenix		Contitech		Goodyear		Sabo	
Codice - Code	Tipo - Type	Codice - Code	Tipo - Type	Codice - Code	Tipo - Type	Codice Code	Tipo - Type	Codice - Code	Codice - Code	Codice - Code	Codice - Code	Codice - Code	Codice - Code	Codice - Code	Codice - Code
3916	C289/C1	289.0.455			1TC 300-30	W01-M58-8613	1T 17 D-4.3	1 F 21 C-5	916 N1	916 N1	9015	SA520097			
3940	C293/A	293.0.411		205536	1TC 300-30	W01-M58-8613	1T 17 D-4.3	1 DK 21 K	940 MB	940 MB	1R 11-703	SA520034			
3940 K	C293/A	293.2.410				W01-M58-8609	1T 17 D-4.3	1 DK 21 K-1	940 MB	940 MB	1R 11-763	SA520034C			
3940 KPP	C293/A	293.2.412		207308	1TC 300-30K	W01-M58-8595	1T 17 D-4.3	1 DK 21 K-2	940 MB	940 MB	1R 11-752	SA520129C			
3941	C293	293.0.511		204466	1TC 300-36	W01-M58-8620	1T 17 D-8.3	1 DK 21	941 MB	941 MB	1R 11-700	SA520028			
3941 K	C293	293.2.510		205170	1TC 300-36	W01-M58-8619	1T 17 D-8.3	1 DK 21-1	941 MB	941 MB	1R 11-702 / 762	SA520028C			
3941-01 KPP	C293	293.2.512		206356	1TC 300-36	W01-M58-8619	1T 17 D-8.3	1 DK 21-2	941 MB	941 MB	1R 11-743	SA520088C			
3942	C292/B	292.0.601				W01-M58-8611	1T 66 F-13.5	1 DK 32 L	942 MB	942 MB	1R 14-700	SA520068			
3943	D276/D	276.0.260		88809	1S 285-18	W01-095-0189	1R 1A 260 285	1 E 21-6	943 N	943 N	9001	SA520026			
3944	D290/B	290.0.390		97619	1S 270-23	W01-095-0121	1R 1B 390-270	1 E 21-6	944 N	944 N	9009	SA520035			
3944	D276/C	276.0.370		88786	1S 285-22	W01-095-0198	1R 1A 370 285	1 E 21 C	945 N	945 N	8012	SA520035			
3945	D276	276.0.420		97555	1S 285-25	W01-095-0197	1R 1A 415 285	1 E 21 C	945 N	945 N	9013	SA520003			
3951	C293/B	293.0.611				W01-M58-8621	1T 17 D-11.8		951 MB	951 MB	1R 11-704	SA520063			
30076 K	D287/D	287.2.670		201715	1T 19 E-6		1T 19 LC-20					SA520147C			
30081 K	D278/D	278.4.535				W01-M58-8747	1T 17 B-11	1 DK 25-1			1R 13-150				
30283 K	D277/D	277.2.520					1 D 28 F3					SA520230C			
31421	C299/E	299.0.490				W01-095-0472	1R 2A 490-305		1421 N	1421 N	9072	SA520092			
31885	C289/C	289.0.450		202265	1SC 270-30	W01-095-0429	1R 2A 445 280	1 F 20 B1	1884 N1 / 1885 N1	1884 N1 / 1885 N1	9003	SA520031			
31924	C289/E	289.0.360							1924 N1	1924 N1		SA520155			
32619 KPP	D278/S	278.1.455		206585	1T 300-37	W01-M58-8612	1T 17 BS-6		4022 NP05	4022 NP05		SA520131C			
32918 K	D277/B	277.4.423		205456	1T 19 E-1	W01-M58-6338	1T 19 L-7	1 D 28 A10	4810 NP05	4810 NP05	1R 14-730	SA520146C			
32923 KPP	D277	277.4.508										SA520207C			
32926 K	D287/C	287.4.601		206333 / 207713	1T 19 E-2L				912 NP01	912 NP01	1R 14-728	SA520132C			
34004	D278/S	278.0.451							4004 NP02	4004 NP02	1R 11-705	SA520062			
34004 K	D278/S	278.4.451		97722 (ex 97334)	1T 323-33		1T 17 BS-6					SA520062C			
34004 KPP	D278/S	278.4.452		203715	1T 300-37	W01-M58-6366	1T 17 BS-6	1 DK 22 E8	4004 NP03	4004 NP03	1R 11-713	SA520090C			
34022	D278/S	278.0.452				W01-M58-0756	1T 17 BS-6		4022 NP02	4022 NP02	1R 11-709	SA520055			
34022 K	D278/S	278.4.453			1T 300-37						1R 11-710	SA520055C			
34022 KPP	D278/S	278.4.454		206340 (ex 204677)	1T 300-37	W01-M58-6367	1T 17 BS-6	1 DK 22 E9	4022 NP03	4022 NP03	1R 11-714	SA520095C			
34023 K	D277	277.4.505		204676	1T 19 E-2	W01-M58-6348	1T 19 L-11	1 D 28 B10	4023 NP03	4023 NP03	1R 14-729	SA520059C			
34028 K	D287/E	287.4.540				W01-M58-8106	1T 19 L-12	1 D 28 F-1	4028 NP02	4028 NP02	1R 14-783				

I nominativi dei costruttori e i relativi riferimenti originali citati nel presente catalogo sono riportati a puro titolo indicativo. I nostri prodotti non sono originali ma con essi intercambiabili.

The name of manufacturers and the o.e. references mentioned in this catalogue are given for cross-reference purposes only. Our products are not original but interchangeable with.

* Solo per il mercato italiano * Only for Italian market



**TABELLA COMPARATIVA MOLLE AD ARIA da codici AIRTECH
AIR SPRINGS CROSS-REFERENCE LIST from AIRTECH codes**

Airtech		GART		CF Gomma		Firestone		Phoenix		Contitech		Goodyear		Sabo	
Codice - Code	Tipo - Type	Codice - Code	Tipo - Type	Codice - Code	Tipo - Type	Codice Code	Tipo - Type	Codice - Code	Codice - Code	Codice - Code	Codice - Code	Codice - Code	Codice - Code	Codice - Code	Codice - Code
34156	D278/G	278.0.421	D278/G	97306 / 207777	1T 323-32	W01-358-9361	1T 15 M-6	1 DK 21 A2	4156 NP05	4156 NP06	1R 12-707	SA520080			
34156 KPP	D278/G	278.4.421	D278/G									SA520089C			
34157 KPP	C284/D	294.2.454	C284/D												
34158	D278/HS	278.0.531	D278/HS			W01-M58-6257	1T 15 MP-9		4158 NP02			SA520091			
34158 KPP	D278/HS	278.1.530	D278/HS			W01-M58-8185	1T 15 MPW-9	1 DK 20 B1	4158 NP03	4158 NP03	1R 12-749	SA520091C			
34158 KPP	D278/HS	278.1.530/1	D278/HS			W01-M58-8185	1T 15 MPW-9	1 DK 20 B1	4158 NP03	4158 NP03	1R 12-749	SA520091C			
34159	D278/H	278.0.511	D278/H	206506	1T 323-40				4159 NP05		1R 12-761	SA520117			
34159 K	D278/H	278.2.515	D278/H									/			
34159-02 KPP	D278/H	278.1.510	D278/H	200751	1T 323-40	W01-M58-9131	1T 15 M-9	1 DK 23 L-9131	4159 NP09	4159 NP09	1R 12-721	SA520094C			
34159-05 K	D278/H	278.2.511	D278/H	202302 / 96978	1T 323-40	W01-379-9091 / 8859	1T 15 M-9	1 DK 23L-25	4159 NP07	4159 NP07	1R 12-702	SA520128C			
34159-10 KPP	D278/H	278.4.511	D278/H	204124/98800	1T 323-40	W01-M58-7548	1T 15 M-9	1 DK 23L-27	4159 NP03	4159 NP03	1R 12-701				
34183-24 K	C282/C	282.1.460	C282/C						4183 NP24			SA520204C			
34390-01	C304	304.0.440	C304	206782	1VSC 285-30	W01-M58-0904	1R 7Z 440-290-B	1 KF 21-1 NP	4390 N1	4390 N1	9507	SA520093			
34390-01 K	C304	304.1.440	C304	207765	1VSC 285-30	W01-M58-8514	1R 7Z 440-290-B	1 KF 21-1	4390 NP01 / NP21	4390 NP01 / NP21	9505	SA520093C			
34390-02	C304	304.0.441	C304	206784	1VSC 285-30	W01-M58-0905	1R 7Z 440-290-C	1 KF 21-2 NP	4390 N2	4390 N2	9508				
34390-02 K	C304	304.1.441	C304	207766	1VSC 285-30	W01-M58-8513	1R 7Z 440-290-C	1 KF 21-2	4390 NP02 / NP22	4390 NP02 / NP22	9506	SA520098C			
34390-03 K	C304	304.1.443	C304	206783	1VSC 285-30				4390 NP03						
34390-04 K	C304	304.1.444	C304	206781	1VSC 285-30				4390 NP04						
34705 P	C302/B	302.0.521	C302/B						4705 N1 P01						
34713	C293/V	293.0.461	C293/V	206778	1TS 300-28				4713 N	4713 N	1R 12-763	SA520072			
34713 K	C293/V	293.1.460	C293/V	207775	1TS 300-28	W01-M58-9706		1 DF 22 C1	4713 NP 02	4713 NP 02	1R 12-762	SA520072C			
34718 K	D278/V	278.1.470	D278/V						4718 NP01	4718 NP01		SA520121C			
34757-01 K	C299/A	299.1.461	C299/A	206785	1VSC 300-26	W01-M58-8521	1R 7Z 460-305-A		4757 NP01 / NP21	4757 NP01 / NP21	9519	SA520177C			
34757-02 K	C299/A	299.1.460	C299/A	206786	1VSC 300-26	W01-M58-8522	1R 7Z 460-305-B		4757 NP02/NP09/NP29	4757 NP02/NP09/NP29	9520	SA520178C			
34813 K	D287	287.4.520	D287	97764	Airspring E2	W01-M58-7358	1T 19 L-11	1 D 28 B9	4813 NP07	4813 NP07	1R 14-727	SA520056C			
34881	C292/A	292.0.461	C292/A	205537	1TC 360-40	W01-M58-8601	1T 66 D-7.0	1 DK 32 K	4881 NP02	4881 NP02	1R 14-701	SA520030			
34881-01 K	C292/A	292.2.460	C292/A			W01-M58-8602	1T 66 D-7.0	1 DK 32 K-1	4881 MB	4881 MB	1R 14-724	SA520030C			
34881-01 KPP	C292/A	292.2.462	C292/A	207309	1TC 360-40K	W01-M58-8666	1T 66 D-7.0	1 DK 32 K-2	4881 MB	4881 MB	1R 14-757	SA520130C			
34882	C289/M	289.0.512	C289/M	207760	1TS 260-32				4882 N1 P01	4882 N1 P01		SA520187			
34882 K	C289/M	289.1.510	C289/M	207701	1TS 260-32				4882 N1 P05	4882 N1 P05		SA520187C			
34883	C304/M3	304.0.513	C304/M3	207761	1TS 290-28				4883 N1 P01	4883 N1 P01	1R 11-804	SA520188			

I nominativi dei costruttori e i relativi riferimenti originali citati nel presente catalogo sono riportati a puro titolo indicativo. I nostri prodotti non sono originali ma con essi intercambiabili.

The name of manufacturers and the o.e. references mentioned in this catalogue are given for cross-reference purposes only. Our products are not original but interchangeable with.

* Solo per il mercato italiano * Only for Italian market



TABELLA COMPARATIVA MOLLE AD ARIA da codici AIRTECH
AIR SPRINGS CROSS-REFERENCE LIST from AIRTECH codes

Airtech		GART		CF Gomma		Firestone		Phoenix		Contitech		Goodyear		Sabo	
Codice - Code	Tipo - Type	Codice - Code	Tipo - Type	Codice - Code	Tipo - Type	Codice Code	Tipo - Type	Codice - Code	Codice - Code	Codice - Code	Codice - Code	Codice - Code	Codice - Code	Codice - Code	Codice - Code
34883 K	304.1.513	C304/M3									4883 N1 P06			SA520188C	
34884	304.0.511	C304/M4		207759	1TS 290-28						4884 N1 P01		1R 11-820	SA520189	
34884 K	304.1.510	C304/M4		207702	1TS 290-28	W01-M58-9879	1T 17 JR-7,2				4884 N1 P06			SA520189C	
34911 K	287.1.540	D287/E		207770	1T 19 E3						4911 NP03		1R 13-714	SA520075C	
34911 N	287.0.541	D287/E									4911 N			SA520075	
34911-04 K	287.1.541	D287/E		207771	1T 19 E3						4912 NP04				
34912	287.0.601	D287/C		206780	1T 19 E4						4912 NP08			SA520060	
34912 K	287.1.600	D287/C		206779	1T 19 E4	W01-M58-8786	1T 19 L-14	1 DK 28 F4			4912 NP07		1R 13-711	SA520060C	
34912-10 K	287.1.603	D287/C		207769	1T 19 E4						4912 NP10			SA520241C	
34913	287.0.603	D287/H		207772	1T 19 E-93	W01-095-0365	1T 19 F-14				4913 NP04		1R 14-755	SA520045	
34913 K	287.1.606	D287/H		206201	1T 19 E-93	W01-M58-9881	1T 19 L-14	1 D 28 H16			4913 NP02		1R 14-753	SA520045C	
34915 P	294.0.531	C294/C									4915 NP03				
34915-01 K	294.1.530	C294/C						1 DK 19-1			4915 NP06				
34933 K	287.1.480	D287/SC				W01-M58-8633	1T 17 HR-8								
34940	293.0.413	C293/A									4940 NP02			SA520053	
34941	293.0.513	C293									4941 NP02			SA520054	
34960	293.0.412	C293/A		207711	1TC 300-30			1 D 21 K-3			4960 NP02		1R 11-801	SA520047	
34960 KPP	293.2.414	C293/A						1 DK 21 K			4960			SA520047C	
34961	293.0.414	C293/A									4961 NP02			SA520071	
36199 K	278.2.415	D278/MA												SA520140C	
36200 K	278.2.500	D278/M												SA520139C	
36251 K	306.2.320	D306				W01-M58-8251	1T 15 LP-3							SA520185C	
36416 K	295.1.485	C295/V				W01-M58-8474	1T 15 UR-9				6608 NP01		1R 10-704	SA520175C	
36418 K	295.1.400	C295/A				W01-M58-8473	1T 15 UR-6				6607 NP01			SA520208C	
36884 K	277.2.421	D277/B		96884	1T 19 E-1	W01-M58-8772	1T 19 L-7	1 DK 28 A7						SA520162C	
36885 K	277.2.503	D277		96885	1T 19 E-2	W01-M58-8794	1T 19 L-11							SA520163C	
374521 K	277.4.521	D277/DA												SA520166C	
37803	294.0.431	C294/V									6605 NP01			SA520182	
37803 K	294.1.430	C294/V				W01-M58-8472	1T 15 LRN-6	1 DF 20 D-1			6605 NP01		1R 11-805	SA520182C	
37804 K	294.1.370	C294/A				W01-M58-8477	1T 15 LRN-3	1 DF 20 E-1			6606 NP01		1R 11-848	SA520215C	
38186 KPP	294.1.451	C294				W01-M58-8186	1T 15 MPW-7	1 DK 20 A1			4157 NP06		1R 11-764	SA520165C	

I nominativi dei costruttori e i relativi riferimenti originali citati nel presente catalogo sono riportati a puro titolo indicativo. I nostri prodotti non sono originali ma con essi intercambiabili.

The name of manufacturers and the o.e. references mentioned in this catalogue are given for cross-reference purposes only. Our products are not original but interchangeable with.

* Solo per il mercato italiano * Only for Italian market



**TABELLA COMPARATIVA MOLLE AD ARIA da codici AIRTECH
AIR SPRINGS CROSS-REFERENCE LIST from AIRTECH codes**

Airtech		GART		CF Gomma		Firestone		Phoenix		Contitech		Goodyear		Sabo	
Codice - Code	Tipo - Type	Codice - Code	Tipo - Type	Codice - Code	Tipo - Type	Codice Code	Tipo - Type	Codice - Code	Codice - Code	Codice - Code	Codice - Code	Codice - Code	Codice - Code	Codice - Code	Codice - Code
382520 K	D278/F	278.2.520					1T 17 DJ-7							SA520143C	/
38608 KPP	C294/R	294.2.460				W01-F88(M58)-8608									/
39002-A3	C294	294.0.451		205598	1TC 300-38	W01-M58-7074	1T 15 MPW-7	1 DK 21 A3		4157 NP05					
39002-A3 KPP	C294	294.2.450		205598	1TC 300-38	W01-M58-7074	1T 15 MPW-7	1 DK 21 A31		4157 NP09				SA520036C	
39002-A3-01 KPP	C294	294.1.450				W01-M58-6315	1T 15 MPW-7	1 DK 20 A51		4157 NP10				SA520127C	
39002-A3-08 KPP	C294	294.1.452				W01-M58-6317	1T 15 MPW-7	1 DK 20 C-2		4157 NP08				SA520181C	
39002-A8 KPP	C294	294.2.451		207463	1T 300-40	W01-M58-6297	1T 15 MPW-7	1 DK 21 A4		4157 NP04				SA520037C	
39002-A8 P	C294/D	294.0.455													
320270	D290/E	290.0.340		202773	1S 270-20V									SA520151	
320285	D276/E	276.0.330		96534	1S 285-20		1T 15 VR-3							SA520153	
330301 K	D278/NA	278.2.300				W01-M58-8192	1T 15 VPR-3							SA520198C	
330302 K	D278/N	278.2.330				W01-M58-8193								SA520205C	
330304 K	D297/B	297.1.430												SA520196C	
330305 K	D297/B	297.1.431												SA520202C	
330307 K	D297/C	297.1.300												SA520197C	
331114 K	D297/A	297.2.315												SA520199C	
331237 K	D278/NA	278.2.300/1													
331238 K	D278/N	278.2.330/1													
331239 K	D297/A	297.2.315/1													
331240 K	D297/B	297.1.430/1													
331241 K	D297/B	297.1.431/1													
331243 K	D297/B	297.1.432/1													
331246 K	D297/C	297.1.300/1													
334506 K	D297/B	297.1.432												SA520201C	
361420 K	D276/R	276.1.420												SA520149C	
361421 K	D276/R	276.1.421												SA520144C	
361480 K	D276/LR	276.1.480												SA520148C	
361481 K	D276/LR	276.1.481												SA520145C	
362421 K	D276/R	276.2.421												SA520167C	
382430 K	D278/E	278.2.430												SA520142C	
391209 K	D278/H	278.2.512		96871	1T 323-40	W01-M58-6299	1T 15 M-9							SA520023C	

I nominativi dei costruttori e i relativi riferimenti originali citati nel presente catalogo sono riportati a puro titolo indicativo. I nostri prodotti non sono originali ma con essi intercambiabili.

The name of manufacturers and the o.e. references mentioned in this catalogue are given for cross-reference purposes only. Our products are not original but interchangeable with.

* Solo per il mercato italiano * Only for Italian market



**TABELLA COMPARATIVA MOLLE AD ARIA da codici AIRTECH
AIR SPRINGS CROSS-REFERENCE LIST from AIRTECH codes**

Airtech		GART		CF Gomma		Firestone		Phoenix		Contitech		Goodyear		Sabo	
Codice - Code	Tipologia - Type	Codice - Code	Tipologia - Type	Codice - Code	Tipologia - Type	Codice Code	Tipologia - Type	Codice - Code	Codice - Code	Codice - Code	Codice - Code	Codice - Code	Codice - Code	Codice - Code	Codice - Code
391210 K	D278/H	278.4.516	1T 323-40 BG	97307	1T 323-40 BG		1T 15 M-9					1R 12-703		SA520006C	
391210 K 1	D278/H	278.4.514	1T 323-40	96864	1T 323-40									SA520006C/1	
391210-01 K	D278/H	278.4.512												SA520168C	
391303 K	D287/B	287.4.580	1T 19 E-3	97343	1T 19 E-3	W01-M58-7380 / 8765	1T 19 L-12	1 D 28 C12				1R 13-734		SA520012C	
391304 K	D287/B	287.4.581	1T 19 E-3	201840	1T 19 E-3	W01-M58-8762	1T 19 L-14	1 DK 28 D3						SA520019C	
391314 K	D287/C	287.4.600				W01-M58-7385 / 8502	1 T19 L14	1 D 28 D2		912 NP02				SA520020C	
391318 K	D277/2F	277.2.500	1T 19 E-2	204371 (ex 93762)	1T 19 E-2	W01-M58-6361	1T 19 L-11	1 DK 28 B7				1R 14-706		SA520021C	
391318 K/1	D277/2F	277.2.504	1T 19 E-2	97730	1T 19 E-2	W01-M58-6363	1T 19 L-11							SA520021C/1	
220-60 / 11150	T291/B	291.1.170												SA520161	
2B-220 / 113001	T291/2	291.2.200	20	206797	20	W01-M58-6910 / 6887	20	2 B 12 R		FD 200-19 1/4 M10		2B 9-223		SA520079	
2B-220-3 / 113002	T291/2	291.2.203	20	207773	20	W01-M58-7894	20F	2 B 12 R3		FD 200-19 P04		2B 9-700		SA520106	
2B-370Hyd / 113361	T274	274.2.210	21 BR	89457	21 BR	W01-M58-7710	233 C							SA520137	
3B-300 / 115002	T271/S	271.3.298	322 BB	204413	322 BB									/	
3B-300 / 115008	T271/S	271.3.296													
3B-300Hyd / 115005	T271	271.3.293	322	87987	322	W01-M58-7992	38 C							SA520108	
3B-310Hyd / 115009	T271/S	271.3.298/1	322 BB	93410	322 BB									SA520136	
														SA520206	

I nominativi dei costruttori e i relativi riferimenti originali citati nel presente catalogo sono riportati a puro titolo indicativo. I nostri prodotti non sono originali ma con essi intercambiabili.

The name of manufacturers and the o.e. references mentioned in this catalogue are given for cross-reference purposes only. Our products are not original but interchangeable with.

* Solo per il mercato italiano * Only for Italian market



TABELLA COMPARATIVA MOLLE AD ARIA da codici SABO
AIR SPRINGS CROSS-REFERENCE LIST from SABO codes

Sabo		GART		CF Gomma		Firestone		Phoenix		Contitech		Goodyear		Airtech	
Code	Code	Code	Type	Code	Type	Code	Type	Code	Type	Code	Type	Code	Type	Code	Type
SA520002	276.0.390	D276/B		92574	1S 285-24	W01-095-0118	1R 1A 390 295	1 E 21	644 N	8017	3644				
SA520003	276.0.420	D276		97555	1S 285-25	W01-095-0197	1R 1A 415 285	1 E 21 C	945 N	9013	3945				
SA520006C	278.4.516	D278/H		97307	1T 323-40 BG					1R 12-703	391210 K				
SA520006C/1	278.4.514	D278/H		96864	1T 323-40		1T 15 M-9				391210 K 1				
SA520009	297.0.390	D297		91016	1S 310-28-RF	W01-095-0021	1R 1C390-310	1 E 25	661 N	8018	3661				
SA520010C	277.4.420	D277/B		87413/1	1T 19 E-1	W01-M58-6345 / 8775	1T 19 L-7	1 D 28 A2	810 MB	1R 14-716	3810 K				
SA520012C	287.4.580	D287/B		97343	1T 19 E-3	W01-M58-7360 / 8765	1T 19 L-12	1 D 28 C12		1R 13-734	391303 K				
SA520019C	287.4.581	D287/B		201840	1T 19 E-3	W01-M58-8762	1T 19 L-14	1 DK 28 D3			391304 K				
SA520020C	287.4.600	D287/C				W01-M58-7365 / 8502	1 T19 L14	1 D 28 D2	912 NP02		391314 K				
SA520021C	277.2.500	D277/2F		204371 (ex 93762)	1T 19 E-2	W01-M58-6361	1T 19 L-11	1 DK 28 B7		1R 14-706	391318 K				
SA520021C/1	277.2.504	D277/2F		97790	1T 19 E-2	W01-M58-6363	1T 19 L-11				391318 K/1				
SA520023C	278.2.512	D278/H		96871	1T 323-40	W01-M58-6289	1T 15 M-9			1R 12-703	391209 K				
SA520026	276.0.260	D276/D		88809	1S 285-18	W01-095-0189	1R 1A 260 285		943 N	9001	3943				
SA520028	293.0.511	C293		204466	1TC 300-36	W01-M58-8620	1T 17 D-8.3	1 DK 21	941 MB	1R 11-700	3941				
SA520028C	293.2.510	C293		205170	1TC 300-36	W01-M58-8619	1T 17 D-8.3	1 DK 21-1	941 MB	1R 11-702 / 762	3941 K				
SA520029	292.0.531	C292		204530	1TC 360-45	W01-M58-8978	1T 66 D-10.8	1 DK 32	881 MB	1R 14-708	3881				
SA520029C	292.2.530	C292		205600	1TC 360-45	W01-M58-8966	1T 66 D-10.8	1 DK 32-1	881 MB	1R 14-712	3881-01 K				
SA520030	292.0.461	C292/A		205537	1TC 360-40	W01-M58-8601	1T 66 D-7.0	1 DK 32 K	4881 NP02	1R 14-701	34881				
SA520030C	292.2.460	C292/A				W01-M58-8602	1T 66 D-7.0	1 DK 32 K-1	4881 MB	1R 14-724	34881-01 K				
SA520031	289.0.450	C289/C		202265	1SC 270-30	W01-095-0429	1R 2A 445 280	1 F 20 B1	1884 N1 / 1885 N1	9003	31885				
SA520032	278.0.430	D278		88788	1S 320-30						3897				
SA520034	293.0.411	C293/A		205536	1TC 300-30	W01-M58-8613	1T 17 D-4.3	1 DK 21 K	940 MB	1R 11-703	3940				
SA520034C	293.2.410	C293/A				W01-M58-8609	1T 17 D-4.3	1 DK 21 K-1	940 MB	1R 11-763	3940 K				
SA520035	276.0.370	D276/C		88786	1S 285-22	W01-095-0198	1R 1A 370 285		944 N	8012	3944				
SA520035	290.0.390	D290/B		97619	1S 270-23	W01-095-0121	1R 1B 390-270	1 E 21-6		9009	3944				
SA520036C	294.2.450	C294		205598	1TC 300-38	W01-M58-7074	1T 15 MPW-7	1 DK 21 A31	4157 NP09	1R 11-106	39002-A3 KPP				
SA520037C	294.2.451	C294		207463	1T 300-40	W01-M58-6297	1T 15 MPW-7	1 DK 21 A4	4157 NP04	1R 11-111	39002-A8 KPP				
SA520040	302.0.376/2	C302				W01-M58-0777	1T 17 AR 4.5	1 DF 25-3	836 M2	1R 12-710	3836-02				
SA520043	302.0.385	C302/A				W01-095-0213	1R2A 380 330	1 E 27	768 N		3768				
SA520044	299.0.450	C299		88802	1SC 290-30	W01-095-0195	1R 2A 460-295	1 F 21	720 N	9008	3720				
SA520045	287.0.603	D287/H		207772	1T 19 E-93	W01-095-0365	1T 19 F-14		4913 NP04	1R 14-755	34913				

I nominativi dei costruttori e i relativi riferimenti originali citati nel presente catalogo sono riportati a puro titolo indicativo. I nostri prodotti non sono originali ma con essi intercambiabili.
The name of manufacturers and the o.e. references mentioned in this catalogue are given for cross-reference purposes only. Our products are not original but interchangeable with.



TABELLA COMPARATIVA MOLLE AD ARIA da codici SABO
AIR SPRINGS CROSS-REFERENCE LIST from SABO codes

Sabo		GART		CF Gomma		Firestone		Phoenix		Contitech		Goodyear		Airtech	
Codice	Code	Codice	Code	Tipologia	Code	Tipologia	Code	Code	Code	Code	Code	Code	Code	Code	Code
SA520045C		287.1.606		D287/H	206201	1T 19 E-93	W01-M58-9881	1T 19 L-14	1 D 28 H16	4913 NP02	1R 14-753	34913 K			
SA520046 / A520048		292.0.380		C292/C	92594	1SC 360-30	W01-095-0207 / 0190	1R1D355-355 / 1R2D390-360	1 E 32	662 N / 762 N	9007 / 9010	3662 / 3762			
SA520047		293.0.412		C293/A	207711	1TC 300-30			1 D 21 K-3	4960 NP02	1R 11-801	34960			
SA520047C		293.2.414		C293/A					1 DK 21 K	4960		34960 KPP			
SA520053		293.0.413		C293/A						4940 NP02		34940			
SA520054		293.0.513		C293						4941 NP02		34941			
SA520055		278.0.452		D278/S			W01-M58-0756	1T 17 BS-6		4022 NP02	1R 11-709	34022			
SA520055C		278.4.453		D278/S		1T 300-37					1R 11-710	34022 K			
SA520056C		287.4.520		D287	97764	Alispring E2	W01-M58-7358	1T 19 L-11	1 D 28 B9	4813 NP07	1R 14-727	34813 K			
SA520059C		277.4.505		D277	204676	1T 19 E-2	W01-M58-6348	1T 19 L-11	1 D 28 B10	4023 NP03	1R 14-729	34023 K			
SA520060		287.0.601		D287/C	206780	1T 19 E4				4912 NP08		34912			
SA520060C		287.1.600		D287/C	206779	1T 19 E4	W01-M58-8786	1T 19 L-14	1 DK 28 F4	4912 NP07	1R 13-711	34912 K			
SA520061A		302.0.376		C302			W01-M58-0776	1T 17 AR 4.5	1 DF 25-1	836 M	1R 12-700	3836			
SA520061C		302.1.375		C302			W01-M58-8722	1T 17 AR 4.5	1 DF 25-11	836 MK1	1R 12-712	3836 K			
SA520062		278.0.451		D278/S						4004 NP02	1R 11-705	34004			
SA520062C		278.4.451		D278/S	97722 (ex 97334)	1T 323-33						34004 K			
SA520063		293.0.611		C293/B			W01-M58-8621	1T 17 D-11.8		951 MB	1R 11-704	3951			
SA520064		304.0.490		C304/B					1 F 21 D	713 N	9066	3713			
SA520065		290.0.420		D290	97608	1S 270-25	W01-095-0295	1R1B 415-270	1 E 21 E	782 N		3782			
SA520067		292.0.533		C292/S	202964	1TCS 360-45		1T 66 E10.8	1 DF 32	725 NP01	1R 14-704	3725			
SA520067C		292.1.534		C292/S			W01-M58-8969	1T 66 E-10.8	1 DF 32	725 NP02	1R 14-747	3725 K			
SA520068		292.0.601		C292/B			W01-M58-8611	1T 66 F-13.5	1 DK 32 L	942 MB	1R 14-700	3942			
SA520069C		302.1.375/2		C302			W01-M58-8721	1T 17 AR 4.5	1 DF 25-13	836 M2 K1	1R 12-711	3836-02K			
SA520070C		277.4.500		D277	87408	1T 19 E-2	W01-M58-6364 / 6339	1T 19 L-11	1 D 28 B2	813 MB	1R 14-705 (061)	3813 K			
SA520070C		277.4.507		D277	87408	1T 19 E-2	W01-M58-6364 / 6339	1T 19 L-11	1 D 28 B2	813 MB	1R 14-705 (061)	3813 K			
SA520071		293.0.414		C293/A						4961 NP02		34961			
SA520072		293.0.461		C293/V	206778	1TS 300-28				4713 N	1R 12-763	34713			
SA520072C		293.1.460		C293/V	207775	1TS 300-28	W01-M58-9706		1 DF 22 C1	4713 NP 02	1R 12-762	34713 K			
SA520075		287.0.541		D287/E						4911 N		34911 N			
SA520075C		287.1.540		D287/E	207770	1T 19 E3				4911 NP03	1R 13-714	34911 K			
SA520079		291.2.200		T291/2	206797	20	W01-M58-6910 / 6887	20	2 B 12 R	FD 200-19 1/4 M10	2B 9-223	2B-220 / 113001			

I nominativi dei costruttori e i relativi riferimenti originali citati nel presente catalogo sono riportati a puro titolo indicativo. I nostri prodotti non sono originali ma con essi intercambiabili.
The name of manufacturers and the o.e. references mentioned in this catalogue are given for cross-reference purposes only. Our products are not original but interchangeable with.



TABELLA COMPARATIVA MOLLE AD ARIA da codici SABO
AIR SPRINGS CROSS-REFERENCE LIST from SABO codes

Sabo		GART		CF Gomma		Firestone		Phoenix		Contitech		Goodyear		Airtech	
Code	Code	Code	Type	Code	Type	Code	Type	Code	Type	Code	Type	Code	Type	Code	Type
SA520080	278.0.421	D278/G													
SA520081C	277.4.506	D277	1T 19E-2	203878	1T 19E-2	W01-M58-6334	1T 19 F-11	1 D 28 B7	4156 NP05	811 MB 3 st	1R 14-718	34156	3811 K		
SA520083	292.0.520	C292/E	1SC 360-43	92593	1SC 360-43	W01-095-0192	1R2D 530 360	1 F 32 B	719 N		8118	3719			
SA520084 / A520085	292.0.450	C292/D	1SC 360-34	92575	1SC 360-34	W01-095-0191 / 0419	1R2D460 360 / 1R2D470 360	1 F 32A / 32A-2	727 N / 728 N		8117	3727 / 3728			
SA520087C	292.2.532	C292	1TC 360-45	206357	1TC 360-45	W01-M58-8967	1T 66 D-10.8	1 DK 32-2	881 MB		1R 14-748	3881-01 KPP			
SA520088C	293.2.512	C293	1TC 300-36	206356	1TC 300-36	W01-M58-8619	1T 17 D-8.3	1 DK 21-2	941 MB		1R 11-743	3941-01 KPP			
SA520089C	278.4.421	D278/G	1T 323-32	97306 / 207777	1T 323-32	W01-358-9361	1T 15 M-6	1 DK 21 A2	4156 NP06		1R 12-707	34156 KPP			
SA520090C	278.4.452	D278/S	1T 300-37	203715	1T 300-37	W01-M58-6366	1T 17 BS-6	1 DK 22 E8	4004 NP03		1R 11-713	34004 KPP			
SA520091	278.0.531	D278/HS				W01-M58-6257	1T 15 MP-9		4158 NP02			34158			
SA520091C	278.1.530/1	D278/HS				W01-M58-8185	1T 15 MPW-9	1 DK 20 B1	4158 NP03		1R 12-749	34158 KPP			
SA520091C	278.1.530	D278/HS				W01-M58-8185	1T 15 MPW-9	1 DK 20 B1	4158 NP03		1R 12-749	34158 KPP			
SA520092	299.0.490	C299/E				W01-095-0472	1R 2A 490-305		1421 N		9072	31421			
SA520093	304.0.440	C304	1VSC 285-30	206782	1VSC 285-30	W01-M58-0904	1R 7Z 440-290-B	1 KF 21-1 NP	4390 N1		9507	34390-01			
SA520093C	304.1.440	C304	1VSC 285-30	207765	1VSC 285-30	W01-M58-8514	1R 7Z 440-290-B	1 KF 21-1	4390 NP01 / NP21		9505	34390-01 K			
SA520094C	278.1.510	D278/H	1T 323-40	200751	1T 323-40	W01-M58-9131	1T 15 M-9	1 DK 23 L-9131	4159 NP09		1R 12-721	34159-02 KPP			
SA520095C	278.4.454	D278/S	1T 300-37	206340 (ex 204677)	1T 300-37	W01-M58-6367	1T 17 BS-6	1 DK 22 E9	4022 NP03		1R 11-714	34022 KPP			
SA520097	289.0.455	C289/C1						1 F 21 C-5	916 N1		9015	3916			
SA520098C	304.1.441	C304	1VSC 285-30	207766	1VSC 285-30	W01-M58-8513	1R 7Z 440-290-C	1 KF 21-2	4390 NP02 / NP22		9506	34390-02 K			
SA520101	298.0.460	D298/C	1S 323-34	92477	1S 323-34				876 N			3876			
SA520106	291.2.203	T291/2	20	207773	20	W01-M58-7894	20F	2 B 12 R3	FD 200-19 P04		2B 9-700	2B-220-3 / 113002			
SA520108	271.3.296	T271/S										3B-300 / 115008			
SA520117	278.0.511	D278/H	1T 323-40	206506	1T 323-40				4159 NP05		1R 12-761	34159			
SA520121C	278.1.470	D278/V							4718 NP01			34718 K			
SA520125C	292.1.533	C292/S				W01-M58-8610	1T 66 D-10.8	1 DF 32	725 NP03		1R 14-756	3725-01 K			
SA520127C	294.1.450	C294				W01-M58-6315	1T 15 MPW-7	1 DK 20 A51	4157 NP10		1R 11-772	39002-A3-01 KPP			
SA520128C	278.2.511	D278/H	1T 323-40	202302 / 96978	1T 323-40	W01-379-9091 / 8859	1T 15 M-9	1 DK 23L-25	4159 NP07		1R 12-702	34159-05 K			
SA520129C	293.2.412	C293/A	1TC 300-30K	207308	1TC 300-30K	W01-M58-8595	1T 17 D-4.3	1 DK 21 K-2	940 MB		1R 11-752	3940 KPP			
SA520130C	292.2.462	C292/A	1TC 360-40K	207309	1TC 360-40K	W01-M58-8666	1T 66 D-7.0	1 DK 32 K-2	4881 MB		1R 14-757	34881-01 KPP			
SA520131C	278.1.455	D278/S	1T 300-37	206585	1T 300-37	W01-M58-8612	1T 17 BS-6		4022 NP05			32619 KPP			
SA520132C	287.4.601	D287/C	1T 19 E-2L	206333 / 207713	1T 19 E-2L				912 NP01		1R 14-728	32926 K			
SA520136	271.3.293	T271	322	87987	322	W01-M58-7992	38 C					3B-300hyd / 115005			

I nominativi dei costruttori e i relativi riferimenti originali citati nel presente catalogo sono riportati a puro titolo indicativo. I nostri prodotti non sono originali ma con essi intercambiabili.
The name of manufacturers and the o.e. references mentioned in this catalogue are given for cross-reference purposes only. Our products are not original but interchangeable with.



TABELLA COMPARATIVA MOLLE AD ARIA da codici SABO
AIR SPRINGS CROSS-REFERENCE LIST from SABO codes

Sabo		GART		CF Gomma		Firestone		Phoenix		Contitech		Goodyear		Airtech	
Codice	Code	Codice	Code	Tipo - Type	Codice - Code	Tipo - Type	Codice - Code	Tipo - Type	Codice - Code	Codice - Code	Codice - Code	Codice - Code	Codice - Code	Codice - Code	Codice - Code
SA520137	274.2.210	T274	89457	21 BR	W01-M58-7710	233 C									2B-370Hyd / 113361
SA520139C	278.2.500	D278/M													36200 K
SA520140C	278.2.415	D278/MA													36199 K
SA520142C	278.2.430	D278/E													382430 K
SA520143C	278.2.520	D278/F													382520 K
SA520144C	276.1.421	D276/R													361421 K
SA520145C	276.1.481	D276/LR													361481 K
SA520146C	277.4.423	D277/B	205456	1T 19 E-1	W01-M58-6338	1T 19 L-7		1 D 28 A10		4810 NP05		1R 14-730			32918 K
SA520147C	287.2.670	D287/D	201715	1T 19 E-6		1T 19 LC-20									30076 K
SA520148C	276.1.480	D276/LR													361480 K
SA520149C	276.1.420	D276/R													361420 K
SA520151	290.0.340	D290/E	202773	1S 270-20V											320270
SA520153	276.0.330	D276/E	96534	1S 285-20											320285
SA520154	296.0.340	D296/D	90609	1S 215-22						819 N					3819
SA520154	296.0.360	D296/C	202189	1S 215-23						1819 N					3819
SA520155	289.0.360	C289/E								1924 N1					31924
SA520161	291.1.170	T291/B													220-60 / 111150
SA520162C	277.2.421	D277/B	96884	1T 19 E-1	W01-M58-8772	1T 19 L-7		1 DK 28 A7							36884 K
SA520163C	277.2.503	D277	96885	1T 19 E-2	W01-M58-8794	1T 19 L-11									36885 K
SA520165C	294.1.451	C294			W01-M58-8186	1T 15 MPW-7		1 DK 20 A1		4157 NP06		1R 11-764			38186 KPP
SA520166C	277.4.521	D277/DA													374521 K
SA520167C	276.2.421	D276/R													362421 K
SA520168C	278.4.512	D278/H													391210-01 K
SA520169C	277.4.520	D277/D													3813-03 K
SA520174C	287.4.522	D287													3811-02 K
SA520175C	295.1.465	C295/V			W01-M58-8474	1T 15 UR-9				6608 NP01		1R 10-704			36416 K
SA520177C	299.1.461	C299/A	206785	1VSC 300-26	W01-M58-8521	1R 7Z 460-305-A				4757 NP01 / NP21		9519			34757-01 K
SA520178C	299.1.460	C299/A	206786	1VSC 300-26	W01-M58-8522	1R 7Z 460-305-B				4757 NP02/NP09/NP29		9520			34757-02 K
SA520181C	294.1.452	C294			W01-M58-6317	1T 15 MPW-7		1 DK 20 C-2		4157 NP08		1R 11-773			39002-A3-08 KPP
SA520182	294.0.431	C294/V								6605 NP01					37803
SA520182C	294.1.430	C294/V			W01-M58-8472	1T 15 LRN-6		1 DF 20 D-1		6605 NP01		1R 11-805			37803 K

I nominativi dei costruttori e i relativi riferimenti originali citati nel presente catalogo sono riportati a puro titolo indicativo. I nostri prodotti non sono originali ma con essi intercambiabili.
 The name of manufacturers and the o.e. references mentioned in this catalogue are given for cross-reference purposes only. Our products are not original but interchangeable with.



TABELLA COMPARATIVA MOLLE AD ARIA da codici SABO
AIR SPRINGS CROSS-REFERENCE LIST from SABO codes

Sabo		GART		CF Gomma		Firestone		Phoenix		Contitech		Goodyear		Airtech	
Codice	Code	Tipo	Type	Codice	Code	Tipo	Type	Codice	Code	Tipo	Type	Codice	Code	Codice	Code
SA520185C		306.2.320	D306					W01-M58-6251		1T 15 LP-3					36251 K
SA520187		289.0.512	C289/M	207760		1TS 260-32						4882 NI P01			34882
SA520187C		289.1.510	C289/M	207701		1TS 260-32		W01-M58-9880		1T 17 TWR-8		4882 NI P05			34882 K
SA520188		304.0.513	C304/M3	207761		1TS 290-28						4883 NI P01	1R 11-804		34883
SA520188C		304.1.513	C304/M3									4883 NI P06			34883 K
SA520189		304.0.511	C304/M4	207759		1TS 290-28						4884 NI P01	1R 11-820		34884
SA520189C		304.1.510	C304/M4	207702		1TS 290-28		W01-M58-9879		1T 17 JR-7.,2		4884 NI P06			34884 K
SA520196C		297.1.430	D297/B										1R 11-829		330304 K
SA520197C		297.1.300	D297/C										1R 11-845		330307 K
SA520198C		278.2.300	D278/NA					W01-M58-8192		1T 15 VR-3			1R 13-746		330301 K
SA520199C		297.2.315	D297/A										1R 11-833		331114 K
SA520201C		297.1.432	D297/B										1R 11-832		334506 K
SA520202C		297.1.431	D297/B										1R 11-830		330305 K
SA520204C		282.1.460	C282/C									4183 NP24			34183-24 K
SA520205C		278.2.330	D278/N					W01-M58-8193		1T 15 VPR-3			1R 12-809		330302 K
SA520206		271.3.298/1	T271/S	93410		322 BB									3B-310H/1 / 115009
SA520207C		277.4.508	D277												32923 KPP
SA520208C		295.1.400	C295/VA					W01-M58-8473		1T 15 UR-6		6607 NP01			36418 K
SA520215C		294.1.370	C294/VA					W01-M58-8477		1T 15 LRN-3		6606 NP01	1R 11-848		37804 K
SA520230C		277.2.520	D277/D									1 DF 20 E-1			30283 K
SA520241C		287.1.603	D287/C	207769		1T 19 E4						1 D 28 F3			
SA520279		276.0.262	D276/D/S	97261		1S 285-18C						4912 NP10			34912-10 K
SA520280		278.0.355	D278/B	88806		1S 320-23									

I nominativi dei costruttori e i relativi riferimenti originali citati nel presente catalogo sono riportati a puro titolo indicativo. I nostri prodotti non sono originali ma con essi intercambiabili.
The name of manufacturers and the o.e. references mentioned in this catalogue are given for cross-reference purposes only. Our products are not original but interchangeable with.



GART Srl - 36050 Bressanvido (Vicenza) ITALY
Via S.Benedetto 95 - Tel. (++39) 0444 660950 - Fax (++39) 0444 460141
www.gart.biz - info@gart.biz